

In partnership with



SENSOR BEARING SOLUTIONS

FOR E-DRIVE MOTORS

A compact and flexible alternative to resolvers



www.ntn-snr.com



With You

SENSOR BEARING SOLUTIONS FOR E-DRIVE MOTORS



The partnership between a sensor specialist and a precision bearing expert provides you with state of the art measurement of the motor shaft angle, with perfect and flexible integration of the position sensing solution, all within your electric motor.

Synchronous Motor

Permanent Magnet Synchronous Motor
or Wound Rotor Synchronous Motor



Battery Electric Vehicles & Hybrid Electric Vehicles

P0 to P4 architecture

EXISTING SOLUTION THE RESOLVER

DRAWBACKS

- Not flexible integration
- Bulky and heavy solution
- Tight assembly of resolver parts to secure a correct measurement
- Complex signal processing
- Lower accuracy during acceleration and breaking phases
- Sensitive to motor EM field

Total:
**6 DIFFERENT
PARTS TO ASSEMBLE**

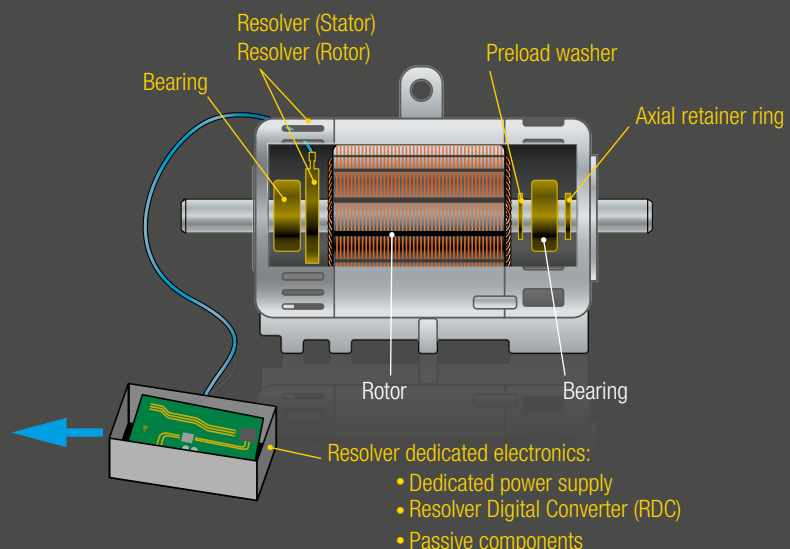

OUR SOLUTION

ALL-IN-ONE COMPACT 1-STEP ASSEMBLY SENSOR BEARING



INCLUDES FUNCTIONS*

- Bearing
- Absolute angle sensor giving SIN/COS outputs (Ring magnet + Hall effect sensor)
- Optional: Pre-load and Axial stop



*Possibility to have separated components

ADVANTAGES OF THE SOLUTION

- Adaptable to every customer application
- More compact and lighter than Resolver + Bearing
- Easy mounting
- New patented magnetic pattern
- State of the art accuracy, not dependent on assembly
- Lowest overall cost
- ISO26262 compliant
- High speed capability

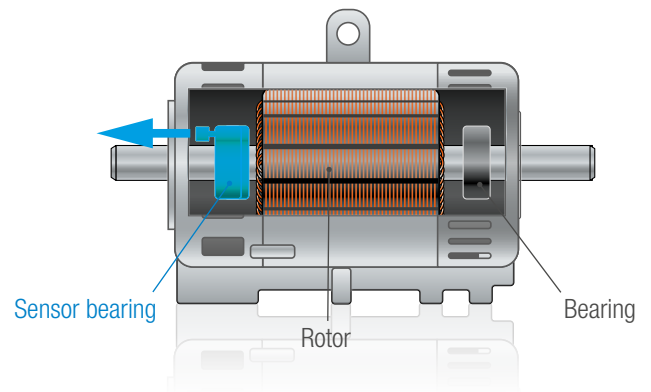

TAILOR-MADE TO FIT ALL E-MOTORS TYPES



AXIAL CONFIGURATION

RADIAL CONFIGURATION

THROUGH-SHAFT

END OF SHAFT



SENSOR BEARING SOLUTIONS

For E-Drive motors

Contact us!



mechatronics@ntn-snr.fr



contact@efiautomotive.com

This document is the exclusive property of NTN-SNR ROULEMENTS. Any total or partial reproduction hereof without the prior consent of NTN-SNR ROULEMENTS is strictly prohibited. Legal action may be brought against anyone breaching the terms of this paragraph.

NTN-SNR ROULEMENTS shall not be held liable for any errors or omissions that may have crept into this document despite the care taken in drafting it. Due to our policy of continuous research and development, we reserve the right to make changes without notice to all or part of the products and specifications mentioned in this document.

© NTN-SNR ROULEMENTS, international copyright 2018.



In partnership with



SENSOR BEARING SOLUTIONS

FOR E-DRIVE MOTORS

A compact and flexible alternative to resolvers

NTN 

www.ntn-snr.com



With You

REVISION HISTORY

Revision	Date	Modifications
1.0	December-2018	Initial release

INTRODUCTION

NTN-SNR and EFI have combined their superior bearing technology and automotive magnetic sensor knowledge to create a series of integrated sensor bearings for e-drive motors.

The sensor bearing is the combination of a high speed automotive bearing with a magnetic angle sensor to provide a solution dedicated to synchronous motor control for hybrid / electric vehicles. It delivers two analog sine and cosine voltages that allow computing the absolute angular electric position. Its high accuracy enables an optimized motor control with high efficiency.

The sensor bearing can be easily customized to different electric motor sizes and number of pole pairs.

This document describes the all in one solution but other configurations are also available like two parts sensors or end of shaft integration.

HIGHLIGHTS

- High compactness thanks to bearing and sensor integration
- Typical accuracy: 1°el for a 4 pole pairs motor, not dependent on assembly
- Easy mounting, no adjustment to take care of
- High speed and acceleration capability, low delay, no front-end filtering
- Lowest overall cost
- Designed for safety applications according to ISO26262
- Sine and cosine single ended or differential signals
- Radial or axial wire output
- Possibility of integrating a spring washer for pre-load
- Possibility of integrating an axial stop
- Compatible with harsh environment, dust, oil

DESCRIPTION – PRINCIPLE



This highly integrated sensor bearing is designed for hollow shaft application where a bearing and an electric angle sensor are required, especially for synchronous motor drive. The numbers of pole pairs of the sensor and the electric motor have generally to match. Moreover single pole pair configuration might allow to fit with various motor topology or ensure second angle sensor source for redundancy purpose.

Through digital processing of the outputs, the True Power On angular position can be computed.

The angular sensor is made up of a magnetic encoder with an innovative patented pattern improving the magnetic field sinusoidal distribution and automotive qualified magnetic cells. The magnetic multi pole target is fixed to the inner ring (the rotating ring) of the bearing and the magnetic sensing unit is fixed to the outer ring (the fixed ring). To ensure safe and reliable operation despite magnetic stray field, a shielding housing protects the system. The bearing, shielding housing, magnetic target and contactless sensing unit are mechanically attached to each other creating a compact ready-to-mount unit.

More details about mechanical integration are available on request.

An axial or radial cable output is terminated by a connector. The unit provides differential analog outputs. With the rotation of the shaft (and the inner ring), the magnetic target creates a low harmonic sinusoidal magnetic field. The magnetic sensing unit converts the magnetic field into two differential analog voltages with a 90-degree phase shift: positive sine, negative sine, positive cosine and negative cosine outputs. The angular position of the inner ring may be calculated using a direct arctangent function, preferably atan2 or a closed tracking loop.

$$\theta_{electric} = \arctan \frac{V_{sine}}{V_{cosine}}$$

$$\theta_{electric} = \text{atan2}(V_{sine}, V_{cosine}) *$$

The ϑ_{ERR} angle error describes the deviation from the ideal angle value when raw output values are used to compute the angle $\vartheta_{electric}$. Amplitude mismatch between sine and cosine channels, offset and orthogonality error are major sources of angular error. Applying in the ECU a real time algorithm that is able to remove these non-idealities will improve the accuracy of the system, reaching the residual angular error ϑ_{COMP_ERR} . For improving the accuracy one step further, more complex algorithms have been tested and can be proposed.

More details about online calibration algorithms are available on request.

* Definitions of functions atan and atan2 may differ depending on the used computing software.

APPLICATIONS

NTN-SNR absolute angular sensor bearing is designed for automotive applications with high speeds and high accuracy such as synchronous electric motor control.

- Traction for electric and hybrid vehicles
- Electric Power Steering
- Actuators

The adoption of NTN-SNR integrated sensor bearing allows detection of the rotor position required for electric motor drive (commutation control) or positioning loop. The angular position value is available immediately upon switch-on and can be called at any time by the subsequent electronics. There is no need to move the shaft to find the reference position.

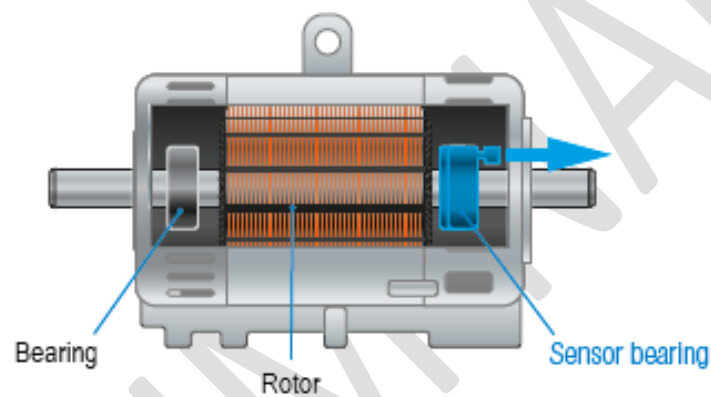

Electric motor cross section

SPECIFICATION

ABSOLUTE MAXIMUM RATINGS (NON OPERATING)

Symbol	Parameter	Min	Max	Unit
V _{cc_range}	Supply voltage	-0.1	7	V
T _{amb_max}	Temperature Range	-40	160	°C
I _{OUT_SRC}	Output Source Current	-	2	mA
I _{OUT_SINK}	Output Sink Current	-	10	mA
B _{MAX}	External Magnetic field induction		75	mT
F _{axial}	Axial force applied to the sensor		650 ¹	N

1: 6008 bearing

Stresses beyond those listed under “Absolute maximum ratings” may cause permanent damage to the device. Exposure to absolute maximum rating conditions for extended periods may affect device reliability.

OPERATING RANGE

Symbol	Parameter	Min	Max	Unit
T _{amb}	Operating Temperature Range	-40	150 ¹⁾	°C
N _{IR}	Rotation speed	0	40000 ¹⁾	rpm

1) Depending on bearing definition

ELECTRIC DATA

Symbol	Parameter	Conditions	Min	Typ.	Max	Unit
V _{cc}	Supply voltage		4.75	5.0	5.25	V
I _{cc}	Supply current	V _{cc} = 5V – No Load			46	mA
T _{POT}	Power-On Time			50		µs
V _{offs}	Offset voltage	Single-ended signal	2.48	2.5	2.52	V
ΔV _{offs}	Offset drift across temperature range		-20		20	mV
V _{peak}	Signal amplitude	Single-ended signal		1.8		V
C _L	Recommended external load capacitance	Output pins			4.7	nF
V _{NOISE}	Output-Referred Noise			15		mV _{pp}
N _{pp}	Pole pairs number ¹⁾			1..16		-
φ	Phase Shift	4 pp configuration	89	90	91	°
∅ _{ERR}	Angular Electrical Error	4 pp configuration		1.5		°
∅ _{COMP_ERR} ²⁾	Compensated Angular Electrical Error	4 pp configuration		1.0		°

1) Pole pairs configuration is fixed by design
2) Refer to the 'Description – Principle' section for definition

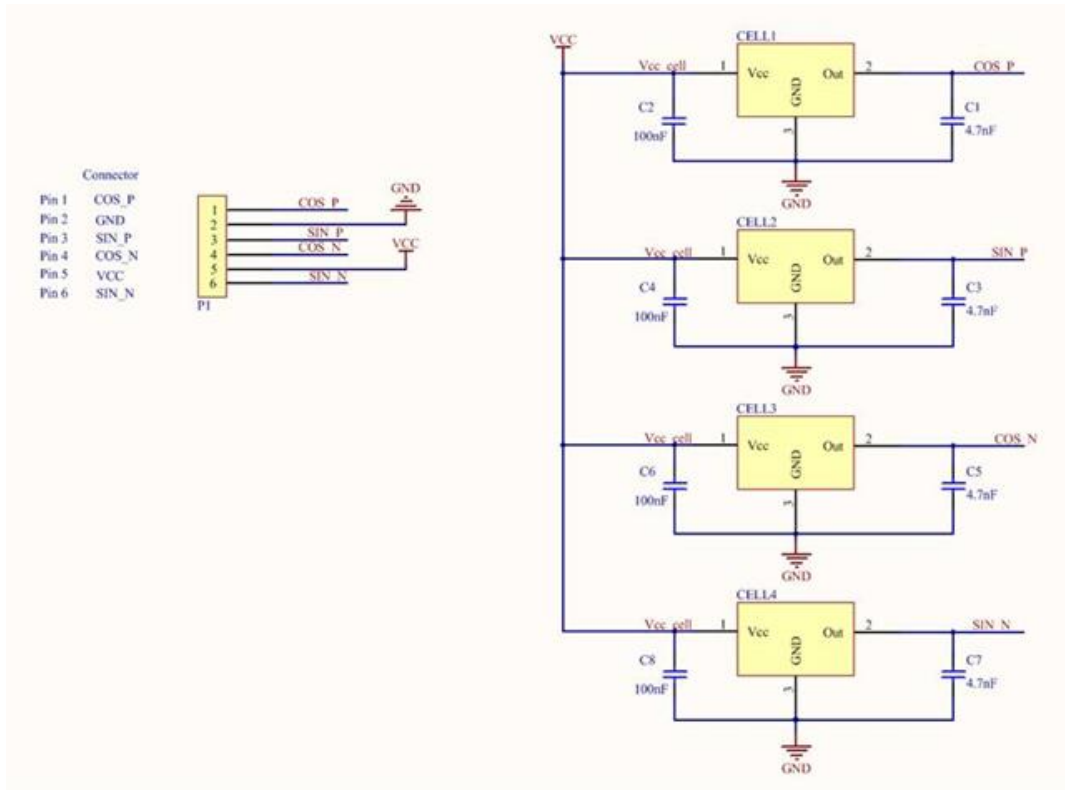

Sensor bearing electric drawing (version with 4 sensing elements)

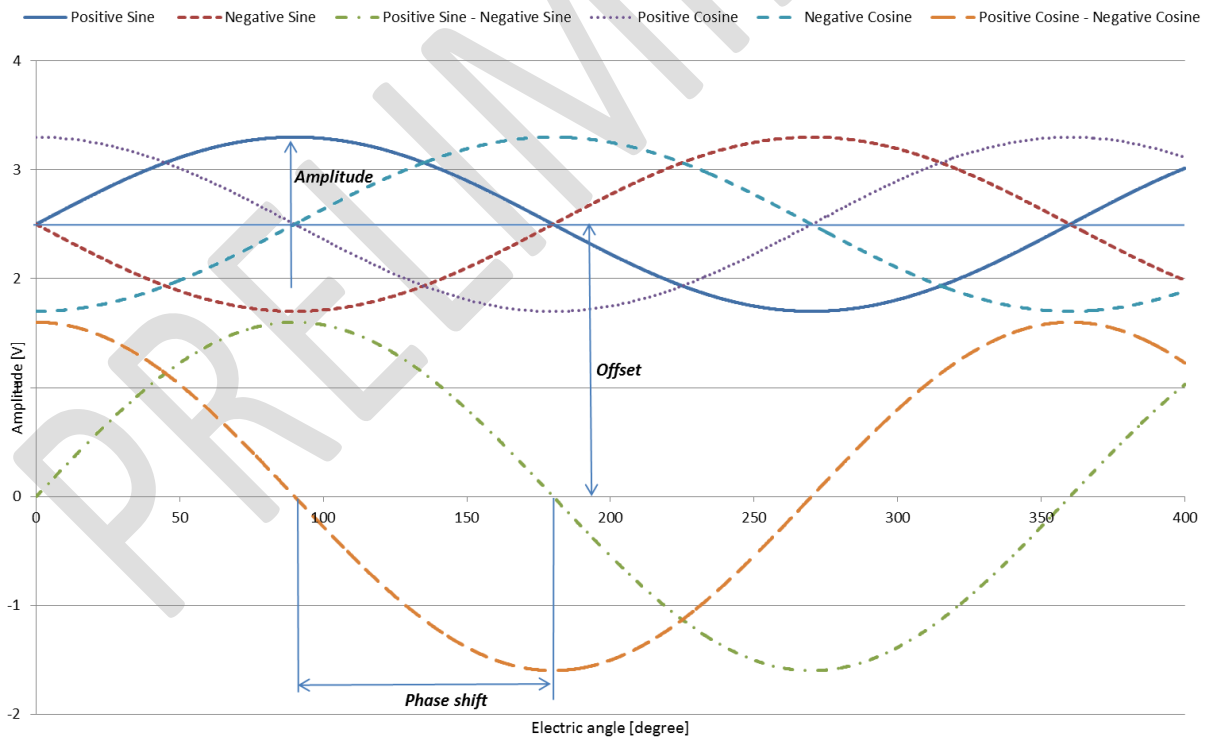

Single-ended and differential output signals

MECHANICAL DATA

Parameter	Value	Notes
Bearing model	Standard series or custom definition	$d \geq 10 \text{ mm}$ $D-d \geq 25 \text{ mm}$ For example 6008, 6300, ...
Shaft diameter (d) [mm]	10..60	Other design upon request
Seal Type	None, Shield, Rubber	Application dependent
Lubrication	Oil or grease	Oil compatibility to check
Sensor unit width (W_{sens}) [mm]	10	Typical value
Wire Size	0.35 mm ²	Typical value Shield and protection possible
Wire Type	PU or PVC	
Connector	None or 6-pol MLK	Other reference possible
Current leakage protection	Ceramic balls, coating	Application dependent

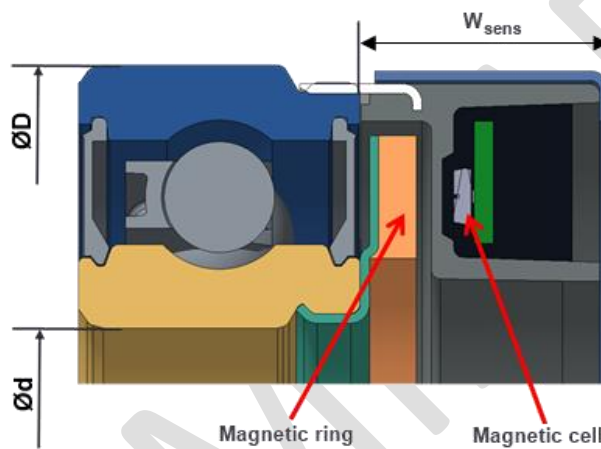

Sensor bearing cross section

SENSOR BEARING ASSEMBLY

Parameter	Value	Notes
Fitting Assembly	Tight fit on inner ring and loose fit on outer ring	Study provided by NTN-SNR
Anti-creeping solution	Proprietary design	
Indexing solution	Proprietary design	
Axial stop	Possible integration into the sensor bearing	

FUNCTIONAL SAFETY

Parameter	Conditions	Unit
Automotive Safety Integrity Level (ASIL)	B, C possible	-
PMHF	Available on request	FIT
SPFM	Available on request	%
LFM	Available on request	%

Dedicated safety analysis are performed according to the with ISO 26262 Road vehicles standard during development to ensure the achievement of the required safety targets. One or several extra sensor outputs can be added for safety or redundancy reasons. More details about safety topics are available on request.

ELECTROSTATIC DISCHARGE PROTECTION

Symbol	Parameter	Voltage Level	Unit
V_{HBM}	ESD	8	kV

Test is based on standard ISO 10605:2001 and IEC 61000-4-2:2001

CONNECTOR / OUTPUT ASSIGNMENT

The sensor bearing unit can delivered with a cable output or an automotive connector for example a Hirschmann 6-pol MLK connector (AV 872-975-xxx)

Connector	Signals
1	0V
2	Supply V_{CC}
3	Positive Sine output
4	Negative Sine output
5	Positive Cosine output
6	Negative Cosine output

HANDLING PRECAUTION

Avoid any shock or impacts during mounting and transport.

Any product dropped on the floor should not be used

Do not mount the sensor bearing by applying a mechanical load to the sensor unit.

Do not put any load to the wires.

Do not carry the bearings by the wires.

Keep away from ferromagnetic particles.



Contact us !



mechatronics@ntn-snr.fr



contact@efiautomotive.com

This document is the exclusive property of NTN-SNR ROULEMENTS. Any total or partial reproduction hereof without the prior written consent of NTN-SNR ROULEMENTS is strictly prohibited. Legal action may be brought against anyone breaching the terms of this paragraph.

NTN-SNR ROULEMENTS shall not be held liable for any errors or omissions that may have crept into this document despite the care taken in drafting it. Due to our policy of continuous research and development, we reserve the right to make changes without notice to all or part of the products and specifications mentioned in this document.

© NTN-SNR ROULEMENTS, international copyright 2018

NTN-SNR ROULEMENTS - 1 rue des Usines - 74000 Annecy
RCS ANNECY B 325 821 072 - Code APE 2815Z - Code NACE 28.15
www.ntn-snr.com