



NTN-SNR LINEAR MOTION:
BALL SCREWS



www.ntn-snr.com



With You

NTN-SNR THE STRENGTH OF A GROUP

We are one of the largest bearing manufacturers in the world in conjunction with the Japanese company NTN.

NTN-SNR has been established in the linear technology market since 1985 and strives to offer a complete and competitive product range. This position allows us to provide our customers with a high level of added value regarding service, quality and product variety. Our sales support and applications engineers are always on hand to offer you optimal support.

Our sales and application engineers are always available. The consulting and planning service is based on many years of interdisciplinary experience.

That means less design effort and costs on the side of the users.



Production facility in Bielefeld

Our sales and applications engineers will gladly help you with their expertise. We are looking forward to your enquiries. Our goal is to achieve joint, constructive solutions.

Product quality, economic efficiency and high user benefits are the basis of a strategic partnership between

NTN-SNR and you – our customer.

Advantages:

- Complete range of linear products
- Production facilities in Europe and Asia
- Optimal support from our technical sales and our application engineers near you - worldwide
- State of the art technology (patented solutions)
- State of the art production methods to ensure highest product quality
- Well organized logistic network to ensure on time delivery
- Customized solutions as "genetic code" in our daily business
- Discovering the most economical solutions together with our valued customers

NTN-SNR leads you towards reliability and performance.



118

Sales agencies

73

Production facilities

16

R & D centers

SNR Ball Screws are universal machine elements that meet the constantly growing demands on the automation of assembly and manufacturing processes. NTN - SNR produces one of the widest product ranges of Ball Screws.

SNR Ball Screws are used in many different applications, such as:

- Machine tools
- Packaging and printing machines
- Special and general engineering
- Aircraft construction
- Automation and assembly lines
- Wood and paper industry
- Semiconductor industry
- Medical engineering
- and such more



The different nut designs are adapted to the variety of applications.

Advantages:

- Wide range of rolled, whirled and ground Ball Screws
- Different nut design types
- Very high load ratings
- Different tolerance classes
- Optimal product selection according to the special requirements
- Standard end machining as well as customized end machining
- Wide range of bearing units for Ball Screws

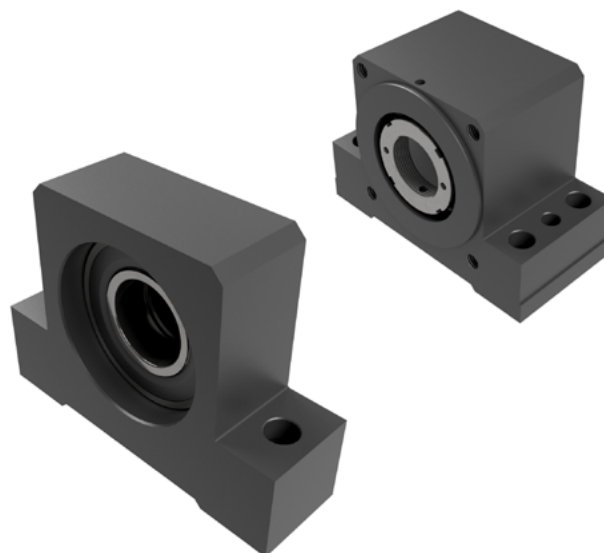

This technical catalogue provides an overview of our Ball Screws range and forms the basis of our discussions with **you – our customer.**

Content

1. _____	Ball Screw basics	7
1.1 _____	Design principles	7
1.2 _____	Manufacturing processes	8
1.2.1 _____	Rolling	8
1.2.2 _____	Whirling	9
1.2.3 _____	Grinding	9
1.3 _____	Features	10
1.3.1 _____	Efficiency	10
1.3.2 _____	Nut design types	11
1.3.3 _____	Ball deflection types	12
1.4 _____	Selection criteria	14
<hr/>		
2. _____	System technology	15
2.1 _____	Definitions	15
2.2 _____	Used standards	15
2.3 _____	Intended use	15
2.4 _____	Safety instructions	16
2.5 _____	Selection of Ball Screws	16
2.5.1 _____	Tolerance classes	17
2.5.2 _____	Tolerances of shape and position	21
2.5.3 _____	Idling torque	28
2.5.4 _____	Preload	30
2.5.5 _____	Rigidity	31
2.5.6 _____	Static safety factor	33
2.5.7 _____	Service lifetime calculation	34
2.5.8 _____	Bearing arrangement of Ball Screws	35
2.5.9 _____	Critical speed	36
2.5.10 _____	DN value	36
2.5.11 _____	Buckling load	37
2.5.12 _____	Tension-compression load	37
2.5.13 _____	Position accuracy	38
2.5.14 _____	Drive power	39
<hr/>		
3. _____	Assembling	40
3.1 _____	Transport and storage	40
3.2 _____	Assembly tolerances	40
3.3 _____	Assembly instructions	42
3.3.1 _____	Assembly of Ball Screw nuts	42
3.3.2 _____	Assembly of fixed bearings	43
3.3.2.1 _____	Assembly of bearings type BST	43
3.3.2.2 _____	Assembly of fixed bearing units' type BSTK	44
3.3.2.3 _____	Assembly of fixed bearing units' type BSTU	44
3.3.2.4 _____	Assembly of fixed bearing units type BK -, EK- and FK	45
3.3.3 _____	Assembly of floating bearings and floating bearing units	45
3.3.4 _____	Assembly of Ball Screws in machines	46
<hr/>		
4. _____	Maintenance and lubrication	47
4.1 _____	General information	47
4.2 _____	Lubrication	47
4.3 _____	Lubricants	47
4.3.1 _____	Anti-corrosion oils	48
4.3.2 _____	Lubrication oils	48
4.3.3 _____	Low-viscosity greases	49
4.3.4 _____	Lubrication greases	50
4.4 _____	Lubrication methods	51
4.4.1 _____	Manual grease gun – SNR - LUB GREASE GUN SET	51
4.4.2 _____	Central lubrication system	52
4.5 _____	Lubricant amounts	53
4.6 _____	Lubrication intervals	57

5.	SNR Ball Screws	59
5.1	Versions and options	59
5.1.1	Nut types	59
5.1.2	Main parameter	61
5.1.3	Correction factors for load ratings	61
5.1.4	Dimension shaft versions	62
5.1.4.1	Rolled shafts	62
5.1.4.2	Whirled shafts	63
5.1.5	Preload classes	64
5.1.5.1	Rolled Ball Screws	64
5.1.5.2	Whirled Ball Screws	65
5.1.6	Sealing options	66
5.1.7	Permissible DN values	66
5.2	Nut types for SNR Ball Screws	67
5.2.1	Compact single nut according DIN 69051 type SC	67
5.2.2	Compact double nut according DIN 69051 type DC	68
5.2.3	Standard single nut according DIN 69051 type SU	69
5.2.4	Standard single nut with pitch offset according DIN 69051 type TW	70
5.2.5	Cylindrical single nut type CI	71
5.2.6	Compact cylindrical single nut type CD	72
5.2.7	Cylindrical screw-in nut type SH	73
5.2.8	Miniature single nut type SK	74
<hr/>		
6.	Accessories	75
6.1	Bearing units	75
6.1.1	Bearing units for Ball Screws with high loads	75
6.1.1.1	Fixed bearings for Ball Screws type BST	75
6.1.1.2	Fixed bearing unit for Ball Screws in block design type BSTK	79
6.1.1.3	Fixed bearings for Ball Screws with mounting holes in the outer ring type BSTU	82
6.1.1.4	Floating bearing unit for Ball Screws in block design type BSTF	85
6.1.1.5	Self-locking precision nut type PRS	86
6.1.2	Bearing units for Ball screws with low and medium loads	88
6.1.2.1	Fixed bearing unit for Ball Screws in block design type BK / EK	88
6.1.2.2	Fixed bearing unit for Ball Screws in flange design type FK	90
6.1.2.3	Floating bearing unit for Ball Screws in block design type BF / EF	92
6.1.2.4	Floating bearing unit for Ball Screws in flange design type FF	93
6.1.2.5	Self-locking precision nut type PRN	94
<hr/>		
6.2	Standard end machining	95
6.2.1	Standard end machining for fixed bearings	96
6.2.1.1	Standard end machining for fixed bearings BST and fixed bearing units BSTK	96
6.2.1.2	Standard end machining for fixed bearings BSTU	98
6.2.1.3	Standard end machining for fixed bearing units BK / EK	99
6.2.1.4	Standard end machining for fixed bearing units FK	100
6.2.2	Standard end machining for floating bearing units	101
6.3	Coupling cones	102
6.4	Deflection belt drive	103
6.5	Lubrication connection	104
<hr/>		
7.	Corrosion protection / Coatings	105
8.	Type code	106
9.	Type list	107
10.	Fits	108
11.	Guide to queries	110
12.	Index	112

1. Ball Screw basics

Design principles of Ball Screws

Ball screw drives are among the most important drive elements for mechanical engineering in linear technology. These drive units consist of a threaded spindle with end machining for the bearings, the ball screw nut with balls, a ball deflection system and sealing elements as well as the bearing units (Figure 1.1).

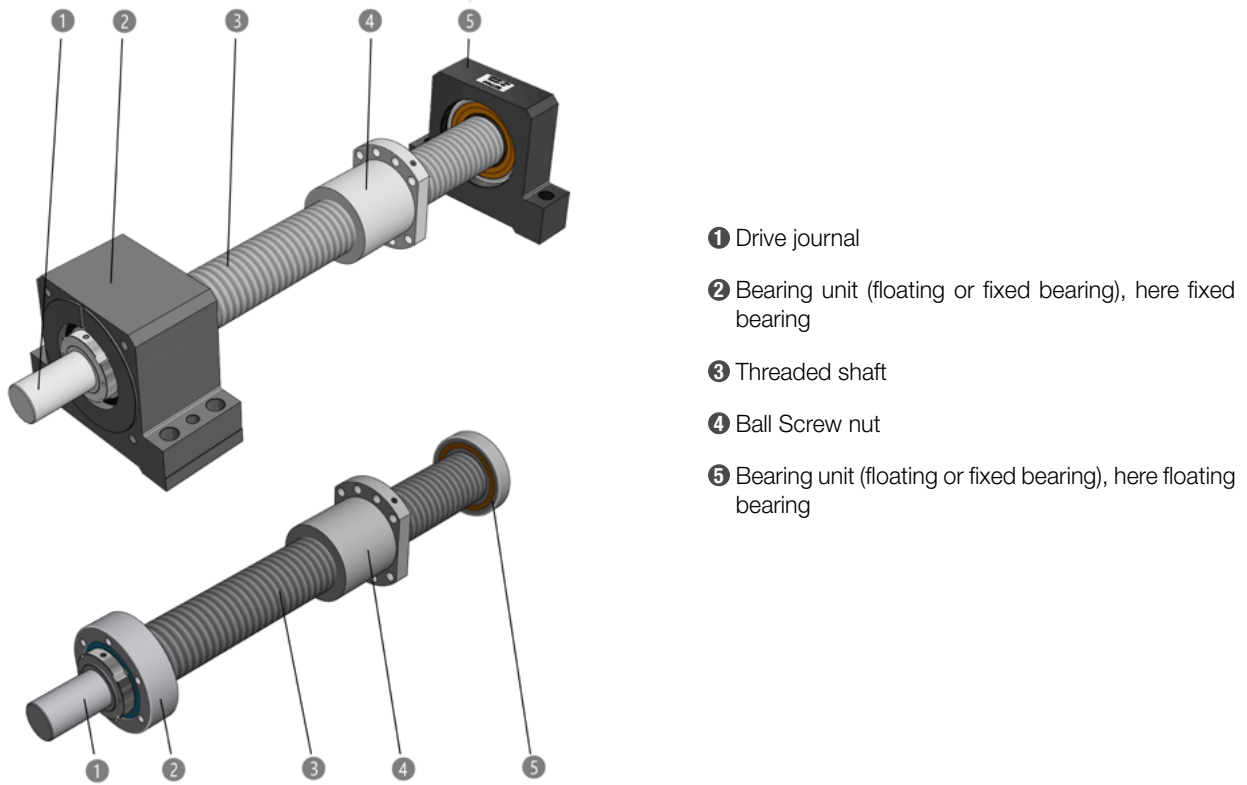

Figure 1.1 ___ Construction of a Ball Screw drive

Ball screw drives are used to convert rotational movements into linear movements and vice versa.

The geometry of the raceways of the threaded spindle and Ball Screw nut are usually designed as a Gothic arc groove (Figure 1.2).

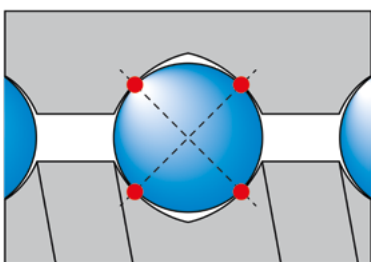

Figure 1.2 ___ Gothic arc groove

Depending on the diameter, pitch and ball size, the threaded spindles can be manufactured as single or multi threaded spindles as well as with right or left-hand helix.

The dimensions shown in Figure 1.3 are important for the designation and technical design of Ball Screws

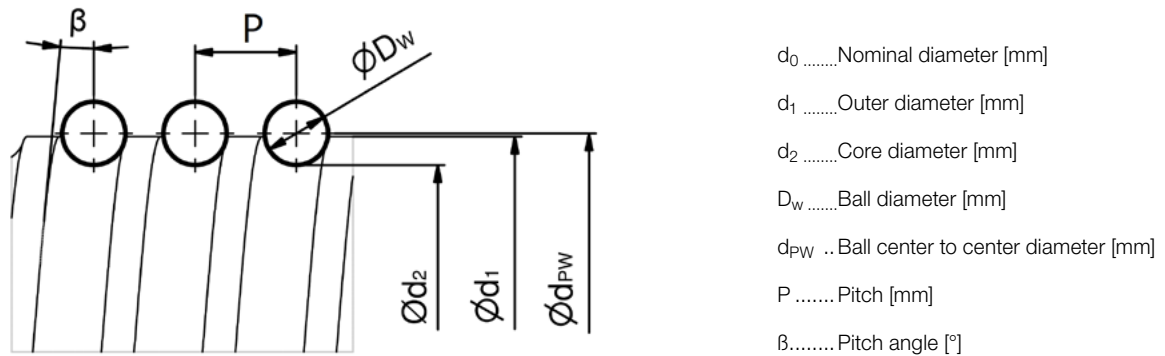

Figure 1.3 ___ Design measures of Ball Screws

The size specification of a ball screw is usually made up of the nominal diameter and pitch, although the nominal diameter cannot always be measured directly on the threaded spindle, depending on the manufacturing process.

1.2 Manufacturing processes of Ball Screw shafts

Ball Screw spindles can be manufactured using the manufacturing processes of rolling, whirling and grinding.

1.2.1 Rolling

Rolling is a fast manufacturing process for threaded spindles. In this process, the raceway profile is pressed into non-hardened raw material ① by cold forming between the rotating rolling tools ② (Figure 1.4). The grain boundaries of the material are not interrupted, and it leads to an increase of the surface hardness.

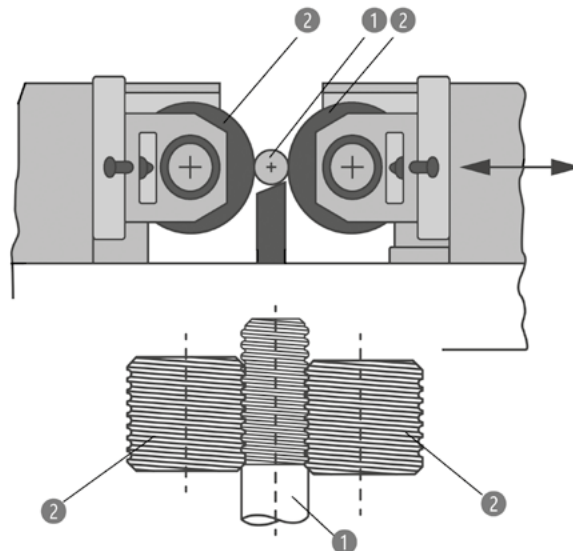

Figure 1.4 ___ Rolling

Then the threaded spindles are inductively hardened and finally the surfaces are cleaned by brushing.

Single and multi-threaded spindles can be produced by rolling. Due to the very short processing times, this process is suitable for very large quantities. The disadvantage of rolling is that separate rolling tools are required for each combination of spindle diameter, pitch, ball size and pitch direction.

1.2.2 Whirling

Whirling is a machine cutting process with geometrical defined cutting edges ①. In this process, the very fast, eccentric rotational movement (n_{wz}) of the tool ② is superimposed on a slow rotation (n_{ws}) and feed movement (v_1) of the threaded spindle ③ (Figure 1.5). The whirling tool ② is inclined by the angle α .

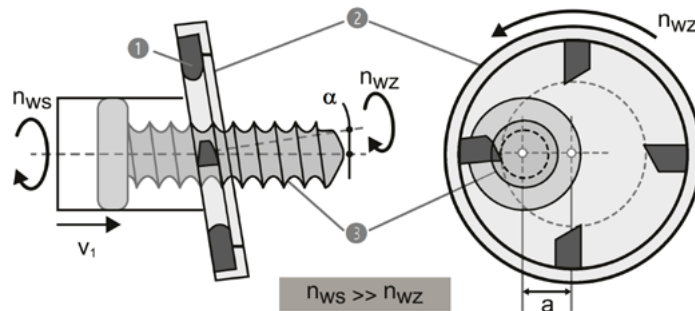

Figure 1.5 ___ Whirling

Depending on the whirling machine used, hardened and non-hardened shafts can be used as the raw material. It is a very flexible manufacturing process with which single-threaded spindles can be manufactured in almost all combinations of spindle diameter, pitch, ball size and pitch direction. With whirling, higher pitch accuracies can be achieved than with rolling. The process is suitable for small and medium quantities.

1.2.3 Grinding

Grinding is a machine cutting process with geometrical un-defined cutting edges. In this process, the very fast rotating (n_{wz}) grinding wheel ① moves along (v_1) the slowly rotating (n_{ws}) threaded spindle ② (Figure 1.6).

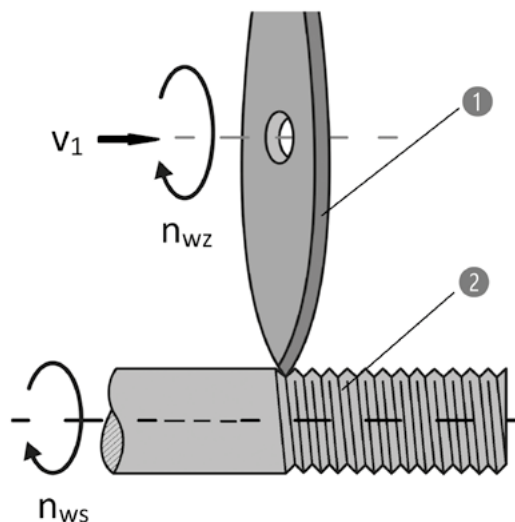

Figure 1.6 ___ Grinding

However, grinding is also a very slow manufacturing process and therefore cost-intensive and suitable for small and medium-sized quantities. The highest pitch accuracies can be achieved with grinding. Hardened shafts are used as the raw material for grinding, where the raceway profile being ground directly into the solid material. In order to reduce the production times, whirled threaded spindles are sometimes used as the starting material, which then get their final pitch accuracy through grinding. It is a very flexible manufacturing process with which single and multi-threaded spindles can be manufactured in almost all combinations of spindle diameter, pitch, ball size and pitch direction.

1.3 Features

1.3.1 Efficiency

Due to the use of rolling balls as transmission elements between the threaded spindle and the nut, Ball Screws are characterized by a very high degree of efficiency. Compared to trapezoidal spindles, the drive torque can be reduced by up to 75%. For this reason, ball screws can convert not only rotary movements into linear movements (Figure 1.7), but also linear movements into rotary movements (Figure 1.8).

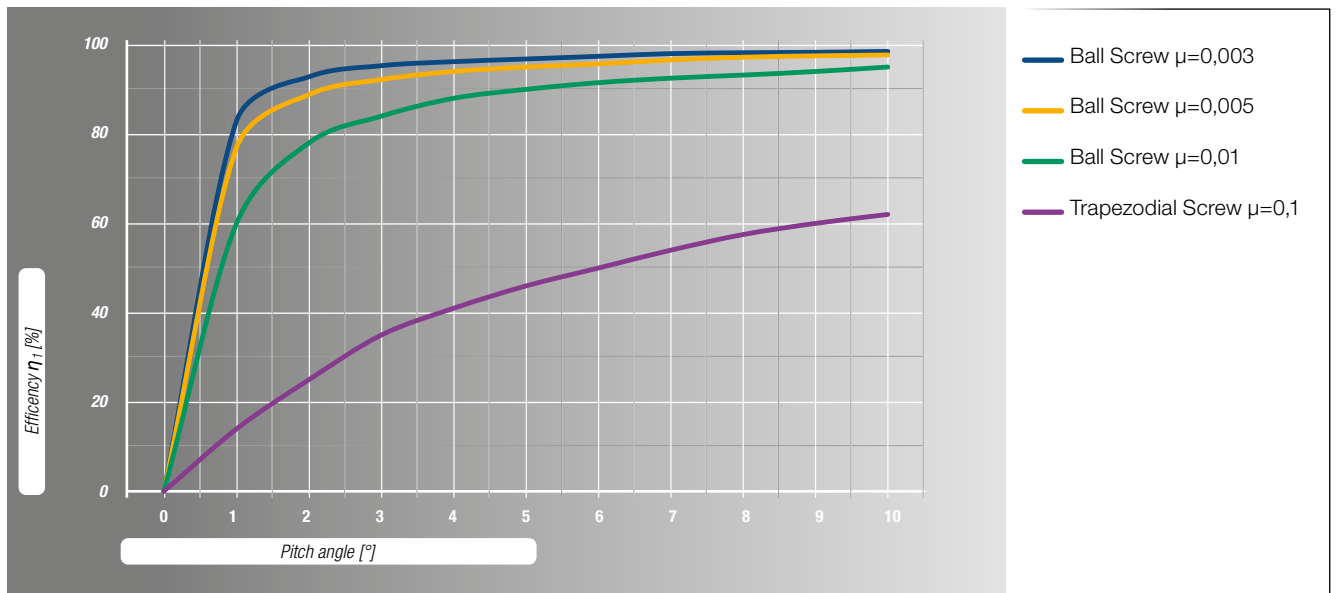

Figure 1.7 ___ Efficiency when converting rotary to linear movement

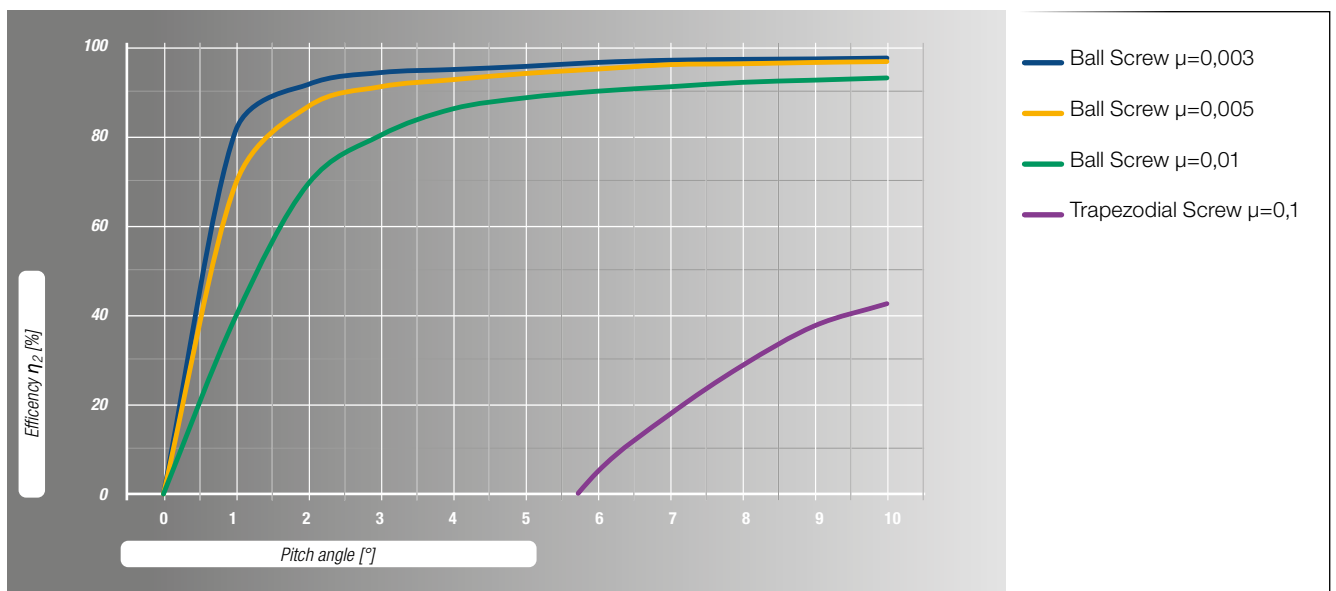

Figure 1.8 ___ Efficiency when converting linear to rotary motion

The calculation of the necessary drive torque of a spindle drive for the conversion of rotary to linear movement as well as the output torque that converts the linear movement into a rotary movement by an acting axial force on a spindle drive is described in Chapter 2.5.14.

The efficiency determined from the diagrams in Figure 1.7 and 1.8 only refer to the Ball Screw drive. For the exact calculation of the drive or output torque, additional influencing factors must be included. These influencing factors are the friction coefficients of the bearing units and the guiding system, the mass moments of inertia, the idling torque resulting from the seals and the preload and the external loads. Detailed information on this can be found in Chapter 2.5.14.

1.3.2 Nut design types

Typical design types of Ball Screw nuts are flange nuts (Figure 1.9), cylindrical (Figure 1.10) and screw-in nuts (Figure 1.11).

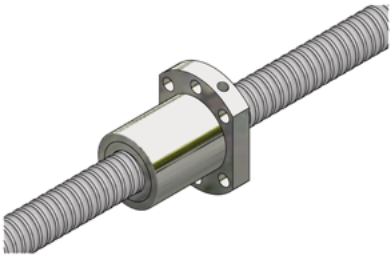

Figure 1.9 __ Flange type nut

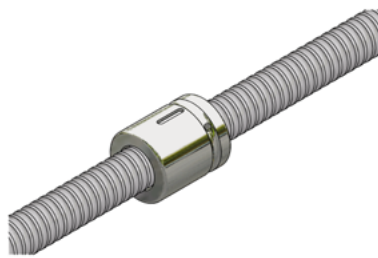

Figure 1.10 __ Cylindrical nut

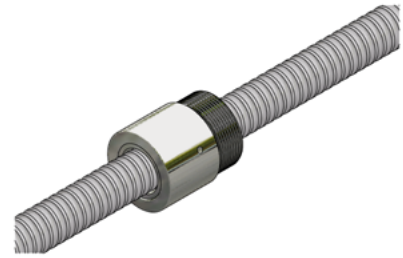

Figure 1.11 __ Screw-in nut

Depending on the size and series, flange nuts, but also partly cylindrical nuts, can be designed as single nuts (Figure 1.12), single nuts with pitch offset (Figure 1.13) or double nuts (Figure 1.14).

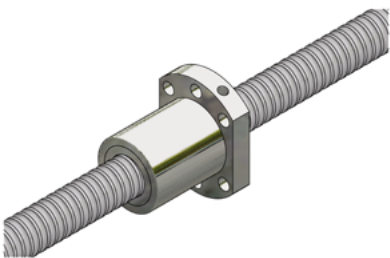

Figure 1.12 __ Single flange type nut

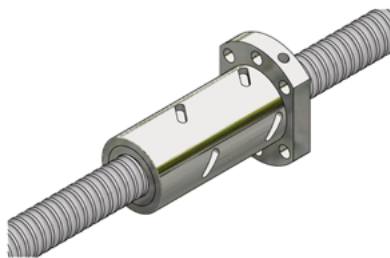

Figure 1.13 __ Single flange type nut with pitch offset

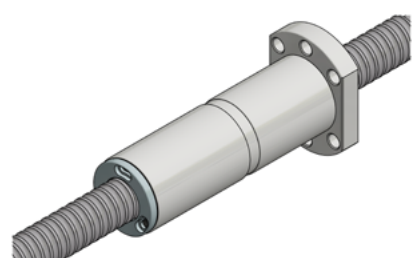
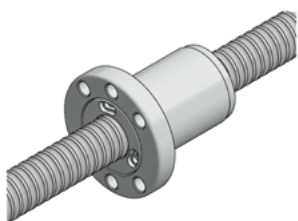
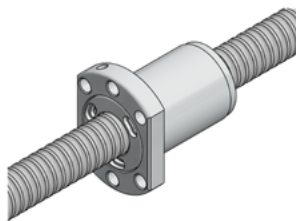

Figure 1.14 __ Double flange type nut

Depending on the installation space, flange type nuts can be designed in three flange types (Figure 1.15).



Round flange
Flange type A



Double cut flange
Flange type B

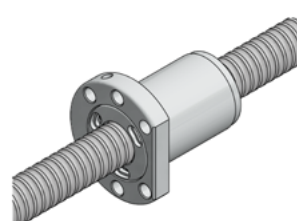

Single cut flange
Flange type C

Figure 1.15 __ Flange types

1.3.3 Ball deflection types

The balls in Ball Screws move in one or more closed ball circuits. The power transmission takes place in the loaded area in which the balls are in contact with the nut and the threaded spindle. The total number of revolutions of the balls around the threaded spindle in the loaded area indicates the number of revolutions.

The balls are unloaded in the ball deflection. The balls can be deflected in different ways. The ball deflections are divided into internal and external deflections as well as single and multiple deflections.

Internal deflection

The most common internal deflection is the so-called deflector circulation (Figure 1.16). Here several of these deflectors are distributed over the length of the nut body.

With this type of ball circulation, the balls revolve once around the threaded spindle and are then returned to the previous thread via the deflectors inserted in the nut body. Because the deflectors are integrated in the nut body and several are used, these nut types have a very compact size and high load ratings.

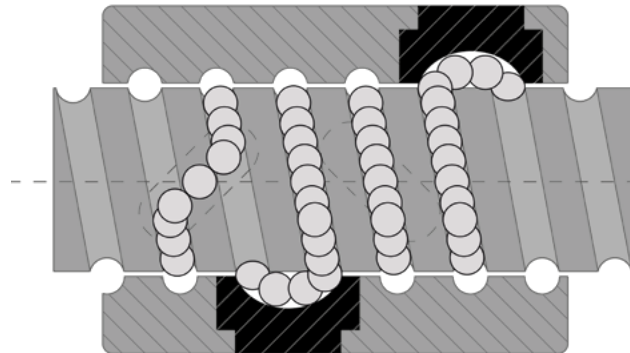

Figure 1.16 __ Deflector ball circulation

A special form of the deflector is the inner deflector (Figure 1.17), which is used in miniature nuts. Here, all of the nut's deflector circulations are arranged in parallel and integrated into one element.

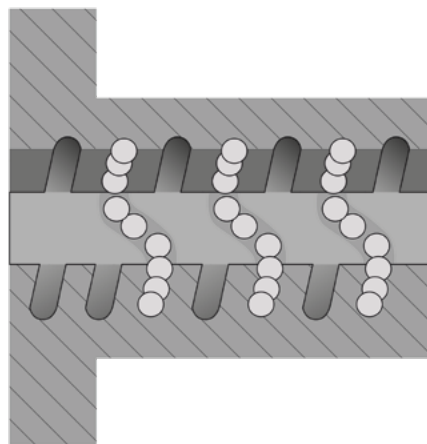

Figure 1.17 __ Inner deflector circulation

External deflection

External deflections can be implemented as end cap deflection (Figure 1.18) or as tube deflection (Figure 1.19).

With the end cap deflection, the balls in the loaded area have uninterrupted contact over the entire length of the nut with the threaded spindle. At the nut ends, the balls are deflected over the end caps into return holes in the nut body. In the case of some types of nuts, the end caps can be reduced to deflection parts inserted into the end face of the nut body. This type of deflection is particularly suitable for high velocity.

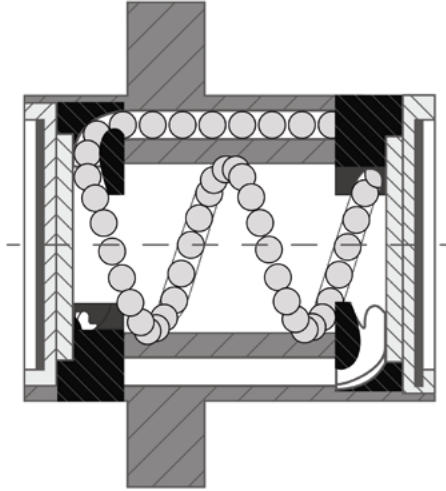

Figure 1.18 __ End cap circulation

In tube deflections, the balls are guided into the deflection tubes via radial holes in the nut body. The deflection tubes are screwed to the nut body via retaining elements. The deflection can take place after two to three revolutions of the balls in the return tube or after the entire length of the nut in one deflection tube. All deflection tubes are arranged in parallel here.

Instead of metal tubes, some types of nuts use plastic elements screwed to the nut body with the same function.

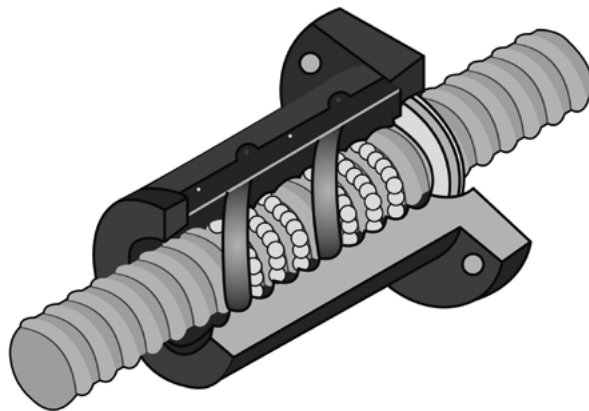
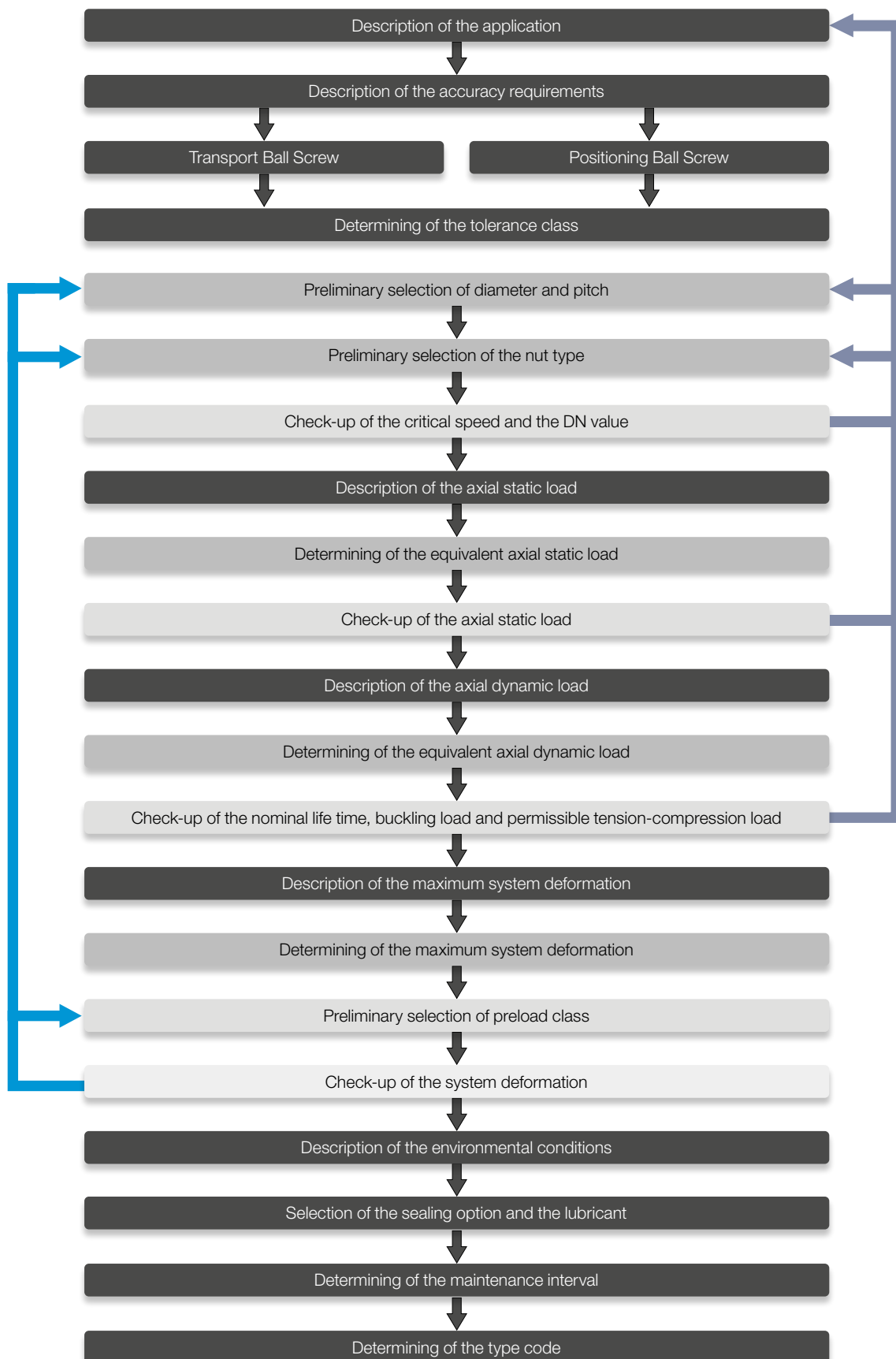

Figure 1.19 __ Tube circulation

1.4 Selection criteria



2. System technology

2.1 Definitions

Service life time L

The service life time L is the number of revolutions that a Ball Screw can handle before the first signs of material fatigue become apparent on the raceways or the rolling elements.

Nominal service life time L_{10}

The nominal service life time L_{10} is the calculated service life time of a single Ball Screw or of a group of equivalent Ball Screws operating under equal conditions that can be reached with a probability of 90%, assuming the use of currently common materials of average manufacturing quality and common operating conditions.

Dynamic load rating C_a

The dynamic load rating C_a is the in size and direction constant, axial load that a Ball screw can theoretically withstand for a nominal service life time of 10^6 revolutions.

Static load rating C_{0a}

The static load rating C_{0a} is the constant axial load resulting in a permanent deformation of 0.0001 times of the ball diameter.

2.2 Used standards

DIN ISO 3408-1 Ball screws – Part 1: Vocabulary and designation (ISO 3408-1:2006)

ISO 3408-2 Ball screws; Part 2: Nominal diameters and nominal leads; metric series

DIN ISO 3408-3 Ball screws; Part 3: Acceptance conditions and acceptance tests (ISO 3408-3:2006)

DIN ISO 3408-4 Ball screws – Part 4: Static axial rigidity (ISO 3408-4:2006)

DIN ISO 3408-5 Ball screws – Part 5: Static and dynamic axial load ratings and operational life (ISO 3408-5:2006)

DIN 69051-2 Machine tools; Ball Screws - Part 2: Nominal diameter and nominal pitch

DIN 69051-5 Machine tools; Ball Screws - Part 5: Connection dimensions for Ball Screw nuts

SNR Ball Screws are compliant with EU directive RoHS1 (2011/65/EU).

SNR Ball Screws are not listed in the Machinery directive 2006/42/EG and are therefore not affected by the directive.

2.3 Intended use

Ball Screws are assemblies. SNR Ball Screws may only be used within the limits of the type-specific load data in the product catalogue or supplementary technical calculations by NTN-SNR for converting rotary to linear movements and vice versa.

Ball Screw drives may only be operated and serviced by persons who are familiar with them and have been informed about the dangers. This also means that this documentation has been completely read and taken note of.

Furthermore, an operating temperature between -10°C and $+75^{\circ}\text{C}$ must be adhered to.

Any other or additional use is considered improper. The manufacturer is not liable for any resulting damage. The user bears the risk alone.

2.4 Safety instructions

The following safety instructions must be observed when using Ball Screws:

- Use Ball Screws only in accordance with the intended use.
- Ball Screws may only be used within the limits of the technical parameters permitted in the product catalogue.
- Only products in a technically perfect condition may be used.
- In principle, changes to ball screws are not permitted.
- Do not reach into moving or rotating parts.
- Ball Screws must not be driven to the end stops.
- Use in safety-relevant applications is only permitted if such use is expressly specified in the product catalogue or has been confirmed by NTN-SNR.
- Ball Screws may only be used under the environmental conditions described in the product catalogue.
- Ball Screws may only be put into operation when it has been established that the assembly or the end product into which the Ball Screws have been installed complies with the country-specific regulations, safety regulations and standards of the application.
- Only accessories and spare parts approved by the manufacturer may be used.
- Do not stand under suspended loads. The individual components of Ball Screws are designed for the service life time of the Ball Screw. In exceptional cases, defects can occur and, if the Ball Screws are installed in a vertical position, the installed components can fall. Appropriate protective measures in accordance with EN ISO 13849-1 must be taken against this.
- The applicable regulations for accident prevention and environmental protection must be observed.
- Appropriate protective equipment must be worn when assembling and working on ball screws.
- Suitable and tested load handling devices that are adapted to the weight are to be used for lifting and transport.
- After all work on the machine, the safety devices must be re-assembled according to regulations and their function checked.
- Before start-up, ensure that all safety devices required for the application are available, properly installed and fully functional.
- Possible danger areas are to be clearly marked.

2.5 Selection of Ball Screws

The selection of Ball Screws is determined by many application factors:

- Accuracy requirements
- Rigidity requirements
- Loads
- Dynamic requirements
- Service life time
- Installation space
- ...

2.5.1 Tolerance classes

Ball Screws are classified according to DIN ISO3408-3 in tolerance classes 10 to 0 with increasing accuracy. In addition to the classification according to DIN ISO, there is occasionally a classification of the tolerance classes according to the Japanese standards JIS B 1191 and JIS B 1192, which differs only slightly from DIN ISO. SNR Ball Screws are specified according to DIN ISO3408.

In addition to the differentiation between tolerance classes, Ball Screws are also differentiated according to transport and positioning Ball Screws. Transport Ball Screws can be designed in tolerance classes T10 to T0 and positioning Ball Screws in tolerance classes P5 to P0. The differentiation between transport and positioning Ball Screws is based on the type and number of tolerances to be checked for the travel distance deviation over the reference length. The diagram in Figure 2.1 shows the tolerances for checking the travel distance deviation.

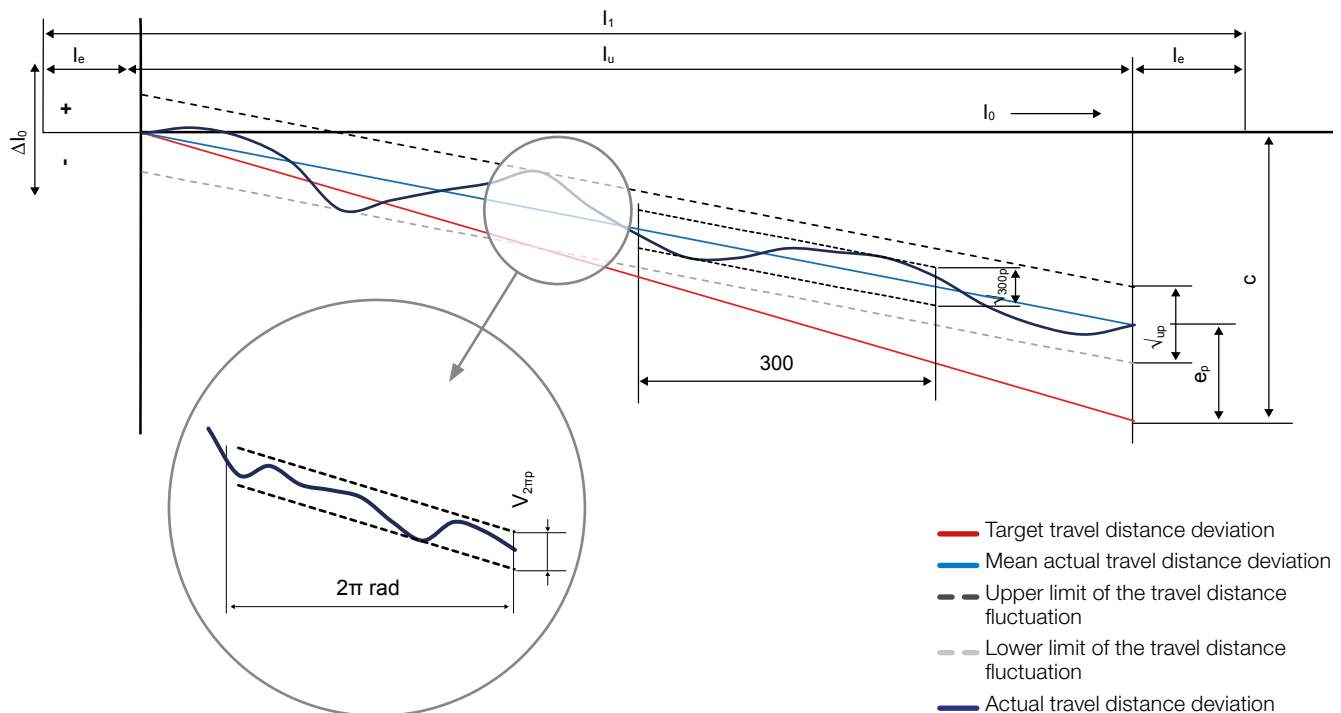

l_0	Nominal travel distance	Product of nominal pitch and number of revolutions
Δl_0	Travel distance deviation	
l_1	Thread length	
l_e	Overrun	Distance over which the required accuracy is not applied
l_u	Useful travel distance	Travel distance + length of the Ball Screw nut
C	Travel distance compensation	Difference between mean travel distance and nominal travel distance over the useful travel distance (standard $C=0$)
e_p	Limit for mean actual travel distance deviation	Half the difference between the maximum and minimum value of the permitted mean actual travel distance
$\sqrt{u_p}$	Tolerance of the travel distance deviation over the useful travel distance l_u	
$\sqrt{300p}$	Travel distance deviation tolerance over 300mm travel distance	Can be measured at any point on the threaded spindle
$\sqrt{2\pi p}$	Travel distance deviation tolerance per revolution	

Figure 2.1 ___ Checking the travel distance deviation of Ball Screws

Table 2.1 contains the overview of the respective test criteria.

Table 2.1 ____ Test criteria for Ball Screws

Travel deviations per reference length	Positioning Ball Screw	Transport Ball Screw
	Test	
Travel compensation C for useful travel l_u	Specified by user	C = 0
Tolerance on specified travel e_p	E1.1	E1.2
Permissible travel variation $\sqrt{v_{up}}$ within useful travel l_u	E2	-
Permissible travel variation $\sqrt{v_{300p}}$ within 300 mm travel	E3	E3
Permissible travel variation $\sqrt{v_{2\sigma rad}}$ within $2\sigma_{rad}$	E4	-

Test E1.1 – Tolerance of the mean travel distance deviations of positioning Ball Screws

The values for the nominal travel distance deviation of positioning Ball Screws depend on the length of the Ball Screw. The permissible tolerances are summarized in Table 2.2.

Table 2.2 ____ Mean travel distance deviations for positioning Ball Screws

Useful travel distance l_u [μm]		Tolerance on specified travel distance e_p [μm] Tolerance class					
>	\leq	0	1	3	5	7	10
0	315	4	6	12	23	-	-
315	400	5	7	13	25	-	-
400	500	6	8	15	27	-	-
500	630	6	9	16	32	-	-
630	800	7	10	18	36	-	-
800	1 000	8	11	21	40	-	-
1 000	1 250	9	13	24	47	-	-
1 250	1 600	11	15	29	55	-	-
1 600	2 000	-	18	35	65	-	-
2 000	2 500	-	22	41	78	-	-
2 500	3 150	-	26	50	96	-	-
3 150	4 000	-	32	62	115	-	-
4 000	5 000	-	-	76	140	-	-
5 000	6 300	-	-	-	170	-	-

Test E1.2 – Tolerance of the mean travel distance deviations of transport Ball Screws

The values for the mean travel distance deviation of transport Ball Screws are only dependent on the useful travel distance l_u . The permissible tolerances are calculated according to the formula in Table 2.3.

Table 2.3 Mean travel distance deviations for transport Ball Screws

Tolerance on specified travel distance l_u						
e_p [μm]						
Tolerance class						
0	1	3	5	7	10	

$$e_p = \pm \frac{l_u}{300} v_{300p}$$

Test E2 – Tolerance of the travel distance deviations $\sqrt{v_{300p}}$ over the useful travel distance l_u of positioning Ball Screws

The values for the travel distance deviation $\sqrt{v_{up}}$ of positioning Ball Screws depend on the length of the Ball Screw. The permissible tolerances are summarized Table 2.4.

Table 2.4 Tolerance of the travel distance deviations $\sqrt{v_{up}}$ of positioning Ball Screws

Useful travel distance l_u [μm]		Travel distance variation $\sqrt{v_{up}}$ [μm]					
>	\leq	Tolerance class					
		0	1	3	5	7	10
0	315	3,5	6	12	23	-	-
315	400	3,5	6	12	25	-	-
400	500	4	7	13	26	-	-
500	630	4	7	14	29	-	-
630	800	5	8	16	31	-	-
800	1 000	6	9	17	34	-	-
1 000	1 250	6	10	19	39	-	-
1 250	1 600	7	11	22	44	-	-
1 600	2 000	-	13	25	51	-	-
2 000	2 500	-	15	29	59	-	-
2 500	3 150	-	17	34	69	-	-
3 150	4 000	-	21	41	82	-	-
4 000	5 000	-	-	49	99	-	-
5 000	6 300	-	-	-	119	-	-

Test E3 – Tolerance of the travel distance deviations $\sqrt{300p}$ over 300 mm of positioning and transport Ball Screws

The values for the travel distance deviation $\sqrt{300p}$ of positioning and transport Ball Screws refer to a distance of 300 mm at each point on the Ball Screw. The permissible tolerances are summarized Table 2.5.

Table 2.5____ Tolerance of the travel distance deviations $\sqrt{300p}$ of Ball Screws

Travel distance variation within 300 mm					
$\sqrt{300p}$ [μm]					
Tolerance class					
0	1	3	5	7	10
3,5	6	12	23	52 ¹	210 ¹

¹ only for transport Ball Screws

Test E4 – Tolerance of the travel distance deviations $\sqrt{2\pi p}$ per revolution of positioning Ball Screws

The values for the travel distance deviation $\sqrt{2\pi p}$ of positioning Ball Screws refer to one revolution of the Ball Screw. The permissible tolerances are summarized Table 2.6.

Table 2.6____ Tolerance of the travel distance deviations $\sqrt{2\pi p}$ of positioning Ball Screws

Travel distance variation within 2π rad					
$\sqrt{2\pi p}$ [μm]					
Tolerance class					
0	1	3	5	7	10
3	4	6	8	-	-

2.5.2 Tolerances of shape and position

Positioning and transport Ball Screws must meet requirements for concentricity, axial runout and parallelism tolerances according to DIN ISO3408-3, depending on the tolerance classes. The respective tolerances to be checked are explained below. Deviating requirements for these tolerances can be defined according to a drawing.

Our NTN-SNR application engineers are available for further information.

Test E5 – Measurement of the concentricity deviation t_5 of the Ball Screw shaft outer diameter of positioning and transport Ball Screws

The measurement takes place on the shaft, which is placed on identical V-blocks, over the length l_5 to determine the straightness between the bearing points AA' according to Figure 2.2. The tolerances are summarized Table 2.7.

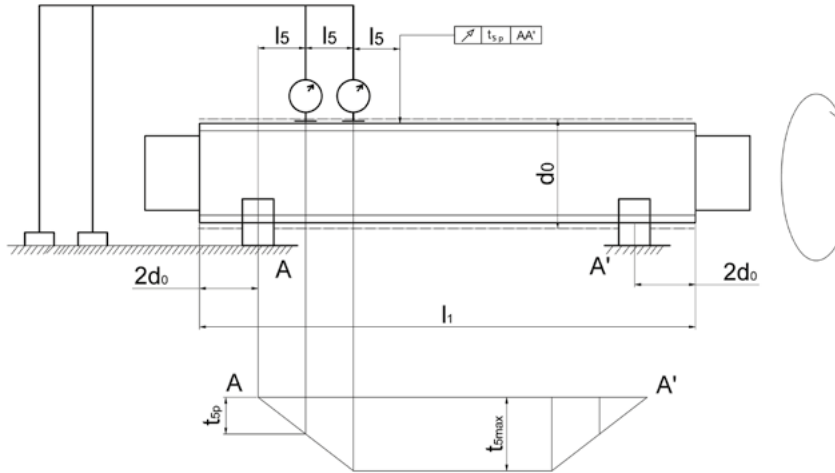

Figure 2.2 — Measurement of the concentricity deviation t_5 of the Ball Screw shaft outer diameter

Table 2.7 — Concentricity deviation t_5 of the Ball Screw shaft outer diameter

Nominal diameter d_0 [mm]		l_5 [mm]	Radial run-out, t_{5p} for l_5 [μ m]					
>	\leq		Tolerance class					
			0	1	3	5	7	10
6	12	80	16	20	25	32	40	80
12	25	160						
25	50	315						
50	100	630						
100	200	1 250						

l_1 / d_0 [mm]			Radial run-out, $t_{5max p}$ for $l_1 > 4 \times l_5$ [μ m]					
>	\leq		Tolerance class					
			0	1	3	5	7	10
-	40		32	40	50	64	80	160
40	60		48	60	75	96	120	240
60	80		80	100	125	160	200	400
80	100		128	160	200	256	320	640

Test E6.1 – Measurement of the concentricity deviation $t_{6,1}$ of the bearing seat related to the length l of positioning and transport Ball Screws

The measurements to determine the concentricity of the bearing seat are carried out on the shaft, which is placed on identical V-blocks AA', according to Figure 2.3. The tolerances are summarized Table 2.8.

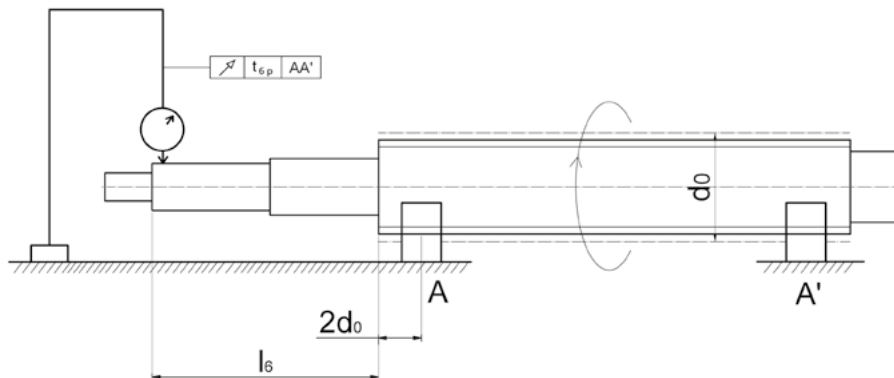

Figure 2.3 ___ Measurement of the concentricity deviation $t_{6,1}$ of the bearing seat

Table 2.8 ___ Concentricity deviation $t_{6,1}$ of the bearing seat

Nominal diameter d_0 [mm]		l [mm]	Radial run-out, $t_{6,1 p}$ for l [μ m]				
>	\leq		Tolerance class				
			1	3	5	7	10
6	20	80	10	12	20	40	63
20	50	125	12	16	25	50	80
50	125	200	16	20	32	63	100
125	200	315	-	25	40	80	125

Test E6.2 – Measurement of the concentricity deviation $t_{6,2}$ of the bearing seat related to the centering line of the shaft of positioning and transport Ball Screws

The measurement is carried out on the Ball Screw shaft placed on a larger number of balls of the same size as in normal use near both ends of the threaded section according to Figure 2.4. The tolerances are summarized Table 2.9.

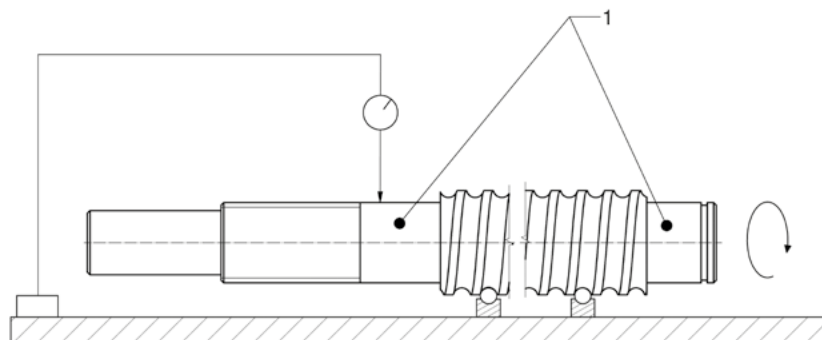

Figure 2.4 ___ Measurement of the concentricity deviation $t_{6,2}$ of the bearing seat

Table 2.9 ___ Concentricity deviation $t_{6,2}$ of the bearing seat

Nominal diameter d_0 [mm]		Radial run-out $t_{6,2 p}$ [μm]					
>	\leq	Tolerance class					
		0	1	3	5	7	10
-	8	3	5	8	10	-	-
8	12	4	5	8	11	-	-
12	20	4	6	9	12	-	-
20	32	5	7	10	13	-	-
32	50	6	8	12	15	-	-
50	80	7	9	13	17	-	-
80	125	-	10	15	20	-	-

Test E7.1 – Measurement of the concentricity deviation $t_{7,1}$ of the journal diameter refer to the bearing seat by calculating the difference for positioning and transport Ball Screws

The measurement is carried out on identical V-blocks AA' placed shaft according to Figure 2.5.
The tolerances are summarized Table 2.10.

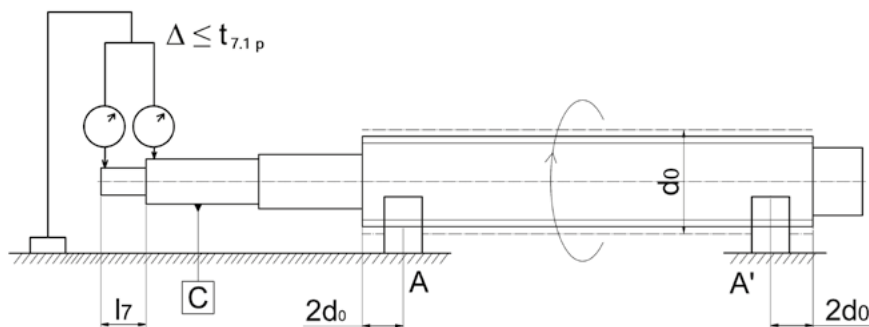

Figure 2.5 ___ Measurement of the concentricity deviation $t_{7,1}$ of the journal diameter

Table 2.10 _ Concentricity deviation $t_{7,1}$ of the journal diameter

Nominal diameter d_0 [mm]		l [mm]	Radial run-out $t_{7,1 p}$ for l [μm]				
>	\leq		Tolerance class				
			1	3	5	7	10
6	20	80	5	6	8	12	16
20	50	125	6	8	10	16	20
50	125	200	8	10	12	20	25
125	200	315	-	12	16	25	32

Test E7.2 – Measurement of the concentricity deviation $t_{7.2}$ of the journal diameter related to the centering line of the bearing seat of positioning and transport Ball Screws

The measurement is carried out on the shaft placed horizontally in identical V-blocks on its bearing seats, as shown in Figure 2.6. The tolerances are summarized Table 2.11.

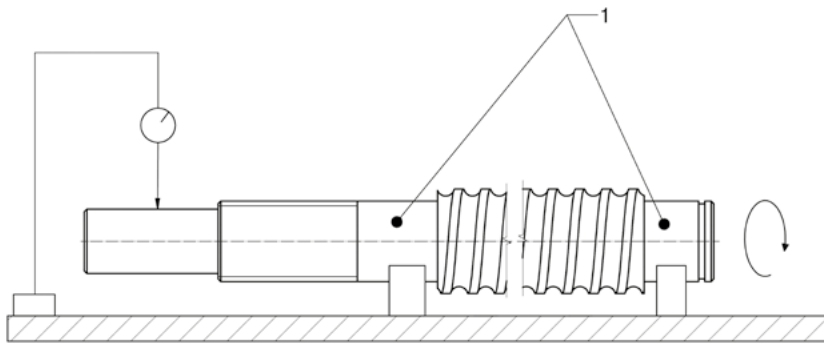

Figure 2.6 ___ Measurement of the concentricity deviation $t_{7.2}$ of the journal diameter

Table 2.11 Concentricity deviation $t_{7.2}$ of the journal diameter

Nominal diameter d_0 [mm]		Radial run-out $t_{7.2p}$ [μm]					
>	\leq	Tolerance class					
		0	1	3	5	7	10
-	8	3	5	8	10	-	-
8	12	4	5	8	11	-	-
12	20	4	6	9	12	-	-
20	32	5	7	10	13	-	-
32	50	6	8	12	15	-	-
50	80	7	9	13	17	-	-
80	125	-	10	15	20	-	-

Test E8.1 – Measurement of the axial run-out $t_{8.1}$ of the bearing surfaces in relation to AA' for positioning and transport Ball Screws

The measurement is carried out on identical V-blocks AA' paced shaft according to Figure 2.7. The tolerances are summarized Table 2.12.

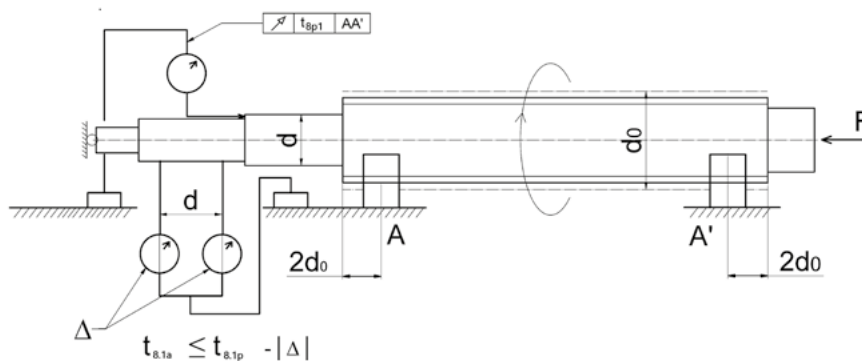

Figure 2.7 Measurement of the axial run-out $t_{8.1}$ of the bearing surfaces

Table 2.12 ___ Axial run-out $t_{8,1}$ of the bearing surfaces

Nominal diameter d_0 [mm]		Axial run-out $t_{8,1 p}$ [μ m]				
>	\leq	Tolerance class				
		1	3	5	7	10
6	63	3	4	5	6	10
63	125	4	5	6	8	12
125	200	-	6	8	10	16

Test E8.2 – Measurement of the axial run-out $t_{8,2}$ of the bearing surfaces related to the centering line of positioning and transport Ball Screws

The measurement is carried out on identical V-blocks AA' paced shaft according to Figure 2.8.
The tolerances are summarized Table 2.13.

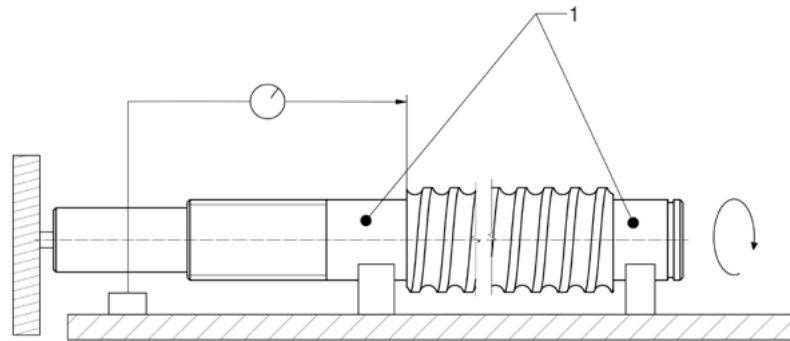

Figure 2.8 ___ Measurement of the axial run-out $t_{8,2}$ of the bearing surfaces

Table 2.13 ___ Axial run-out $t_{8,2}$ of the bearing surfaces

Nominal diameter d_0 [mm]		Axial run-out $t_{8,2 p}$ [μ m]					
>	\leq	Tolerance class					
		0	1	3	5	7	10
-	8	2	3	4	5	-	-
8	12	2	3	4	5	-	-
12	20	2	3	4	5	-	-
20	32	2	3	4	5	-	-
32	50	2	3	4	5	-	-
50	80	3	4	5	7	-	-
80	125	-	4	6	8	-	-

Test E9 – Measurement of the axial runout t_{gp} of the contact surfaces of the Ball Screw nut based on AA' of preloaded positioning and transport Ball Screws

The measurement is carried out on identical V-blocks AA' paced shaft according to Figure 2.9.
The tolerances are summarized Table 2.14.

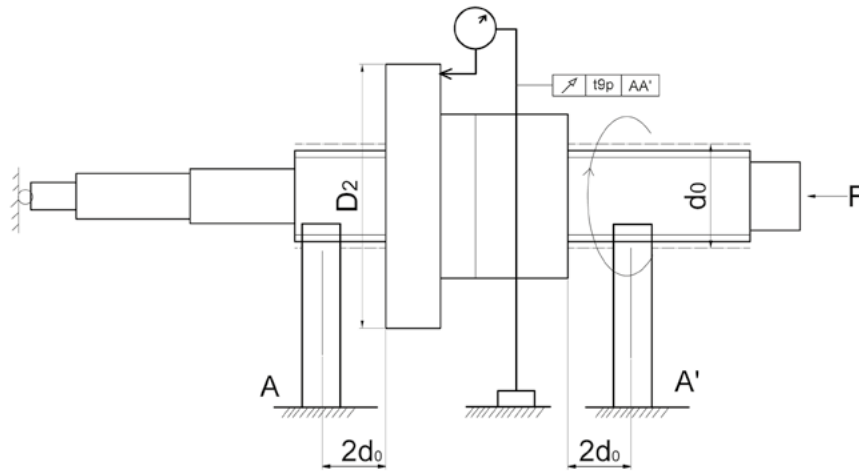

Figure 2.9 __ Measurement of the axial runout t_{gp} of the contact surfaces of the Ball Screw nut

Table 2.14 __ Axial runout t_{gp} of the contact surfaces of the Ball Screw nut

Flange outer diameter D_2 [mm]		Axial run-out t_{gp} [μm] Tolerance class					
>	\leq	0	1	3	5	7	10
16	32	8	10	12	16	20	-
32	63	10	12	16	20	25	-
63	126	12	16	20	25	32	-
126	250	16	20	25	32	40	-
250	500	-	-	32	40	50	-

Test E10 – Measurement of the radial runout t_{10} of the outer diameter of the Ball Screw nut based on AA' of preloaded positioning and transport Ball Screws

The measurement is carried out on identical V-blocks AA' paced shaft according to Figure 2.10. The tolerances are summarized Table 2.15.

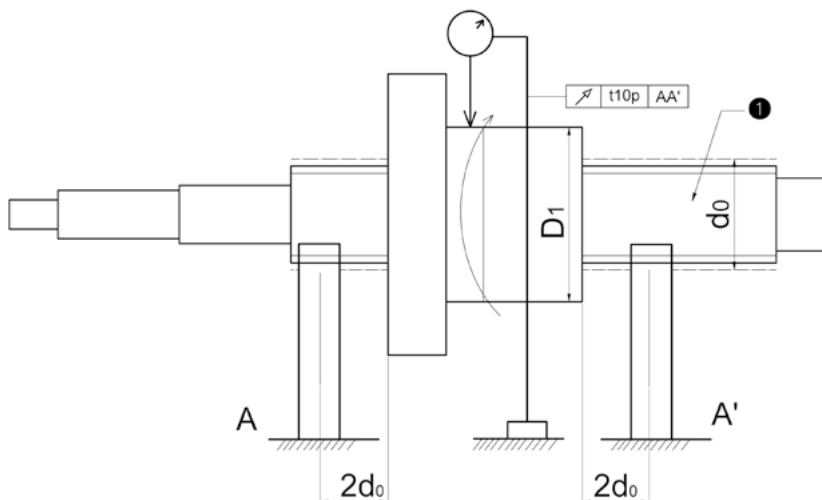

Figure 2.10 _ Measurement of the radial runout t_{10} of the outer diameter of the Ball Screw nut

Table 2.15 __ Radial runout t_{10} of the outer diameter of the Ball Screw nut

Nut outer diameter D_1 [mm]		Radial run-out t_{10p} [μm] Tolerance class					
>	\leq	0	1	3	5	7	10
16	32	8	10	12	16	20	-
32	63	10	12	16	20	25	-
63	126	12	16	20	25	32	-
126	250	16	20	25	32	40	-
250	500	-	-	32	40	50	-

2.5.3 Idling torque

The idling torque of a Ball Screw is composed of the idling torque by the preload and the idling torque of the sealing elements. The mean idling torque T_{p0} by preload is calculated according to Formula 2.1 and is subject to deviations according to DIN ISO 3408 depending on the tolerance class according to Diagram 2.11 and Table 2.15.

$$T_{p0} = \frac{F_{pr} \times P}{2\pi \times 10^3}$$

[Formula 2.1] Starting torque

T_{p0}	Mean idling torque by preload [Nm]
F_{pr}	Preload force [N]
P	Pitch [mm]

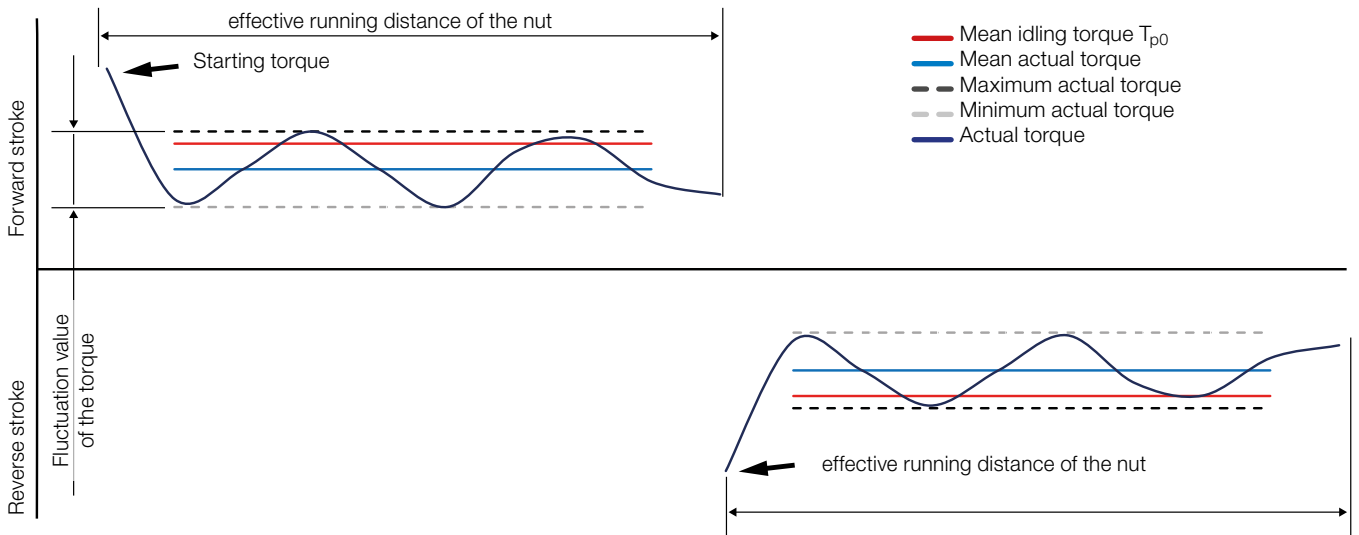

Figure 2.11 __ Idling torque deviation of Ball Screws

Table 2.16 ___ Idling torque deviation of Ball Screws

Mean idling torque [mm]		Total length ≤ 4 000 mm Thread length Nominal diameter ≤ 40 Tolerance class					
		0	1	3	5	7	10
>	≤	Δ T _{pp} [% von T _{p0}]					
0,2	0,4	± 30	± 35	± 40	± 50	-	-
0,4	0,6	± 25	± 30	± 35	± 40	-	-
0,6	1,0	± 20	± 25	± 30	± 35	± 40	-
1,0	2,5	± 15	± 20	± 25	± 30	± 35	-
2,5	6,3	± 10	± 15	± 20	± 25	± 30	-
6,3	10,0	-	-	± 15	± 20	± 30	-

Mean idling torque [mm]		Total length ≤ 4 000 mm 40 < Thread length Nominal diameter ≤ 60 Tolerance class					
		0	1	3	5	7	10
>	≤	Δ T _{pp} [% von T _{p0}]					
0,2	0,4	± 40	± 40	± 50	± 60	-	-
0,4	0,6	± 35	± 35	± 40	± 45	-	-
0,6	1,0	± 30	± 30	± 35	± 40	± 45	-
1,0	2,5	± 25	± 25	± 30	± 35	± 40	-
2,5	6,3	± 20	± 20	± 25	± 30	± 35	-
6,3	10,0	-	-	± 20	± 25	± 35	-

Mean idling torque [mm]		Total length > 4 000 mm Tolerance class					
		0	1	3	5	7	10
>	≤	Δ T _{pp} [% von T _{p0}]					
0,2	0,4	Not specified					
0,4	0,6						
0,6	1,0	-	-	± 40	± 45	± 50	-
1,0	2,5	-	-	± 35	± 40	± 45	-
2,5	6,3	-	-	± 30	± 35	± 40	-
6,3	10,0	-	-	± 25	± 30	± 35	-

2.5.4 Preload

Preload eliminates axial clearance and increases rigidity of a Ball Screw. In order to realize preload in Ball Screws, there are various possibilities.

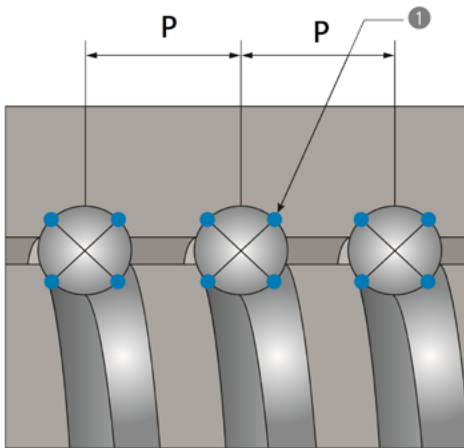

For standard single nuts, balls with a defined oversize can be mounted. Due to the four-point contact of the balls (Figure 2.12), the friction increases very sharply, so that this preload method is only suitable for Ball Screws without axial clearance or light preload.

- P** Pitch
- 1** Ball with four-point contact

Figure 2.12 _ Single nut with preload

Another possibility for preload in single nuts is pitch offset. These nuts contain a defined offset in the middle between the ball deflections. Thus, the balls get two-point contact (Figure 2.13) with only a slight increase in friction. This preload method is suitable for medium preload.

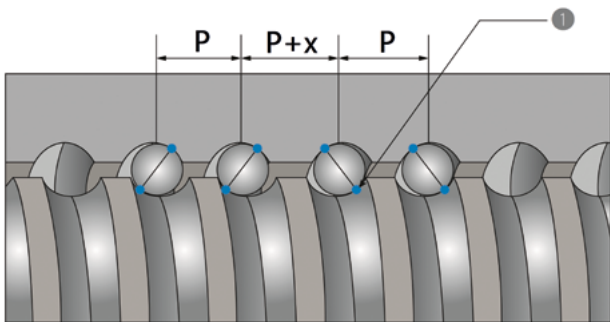

- P** Pitch
- x** Pitch offset
- 1** Ball with two-point contact

Figure 2.13 __ Single nut with pitch offset and preload

For double nuts, the preload is achieved by installing a spacer element with a defined thickness. The two nut halves are braced against each other. Thus, the balls get two-point contact (Figure 2.14) with only a slight increase in friction. This preload method is suitable for medium and high preload.

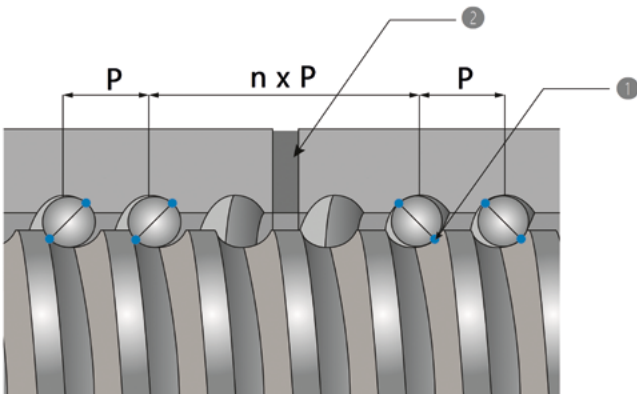

- P** Pitch
- 1** Ball with two-point contact
- 2** Distance element

Figure 2.14 __ Double nut with preload

2.5.5 Rigidity

The increase in the axial rigidity of feeding axis with Ball Screws is necessary to reduce the displacement under the influence of external loads and to increase the positioning accuracy.

The elastic axial displacement of a feeding axis under axial load is calculated according to Formula 2.2.

$$\sigma = \frac{10^3 \times \Delta F_a}{K}$$

[Formula 2.2]

σ Elastic axial displacement [μm]
 ΔF_a Variation of the axial force [kN]
 K Axial overall rigidity [N/ μm]

The axial overall rigidity consists of various individual rigidities according to Formula 2.3.

$$\frac{1}{K} = \frac{1}{K_N} + \frac{1}{K_S} + \frac{1}{K_B} + \frac{1}{K_A}$$

[Formula 2.3]

K Axial overall rigidity [N/ μm]
 K_N Axial rigidity of the nut [N/ μm]
 K_S Axial rigidity of the shaft [N/ μm]
 K_B Axial rigidity of the bearing unit [N/ μm]
 K_A Axial rigidity of the nut adaption [N/ μm]

Axial rigidity of the nut K_N

The axial rigidity of the nut is mainly determined by the preload.

Nuts without preload

The theoretical information in the data tables for Ball Screw nuts without preload in Chapter 5.2 are based on nuts with an axial load of 30% of the dynamic load rating. If the axial load is more than 30% of the dynamic load rating, the rigidity value is calculated according to Formula 2.4, whereby 80% of the dynamic load rating must not be exceeded.

$$K_{N80} = 0,8 K_N \sqrt[3]{\frac{F_a}{0,3 C_a}}$$

[Formula 2.4]

K_{N80} Axial rigidity of the nut with axial load $>0,3C_a$ [N/ μm]
 K_N Axial rigidity of the nut [N/ μm]
 F_a Variation of the axial force [kN]
 C_a Dynamic load rating [kN]

Nuts with preload

The theoretical information in the data tables for Ball Screw nuts with preload in Chapter 5.2 are based on nuts with a preload of 10% of the dynamic load rating. If the preload deviates from the 10% of the dynamic load rating, the rigidity value is calculated according to Formula 2.5.

$$K_{N10} = 0,8 K_N \sqrt[3]{\frac{F_{a0}}{0,1 C_a}}$$

[Formula 2.5]

K_{N10} Axial rigidity of the nut with preload $0,1C_a$ [N/ μm]
 K_N Axial rigidity of the nut [N/ μm]
 F_{a0} Preload forc [kN]
 C_a Dynamic load rating [kN]

Axial rigidity of the shaft K_S

The axial rigidity of the shaft is mainly determined by the bearing arrangement.

For the bearing arrangements fixed-supported and fixed-free (Figure 2.15 and 2.16), the rigidity value is calculated according to Formula 2.6.

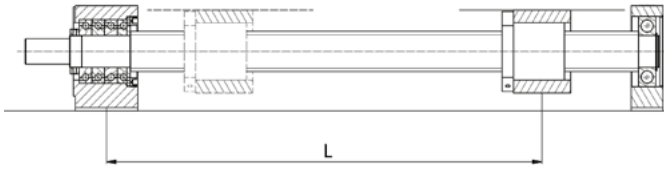

Figure 2.15 __ Bearing arrangement fixed - supported

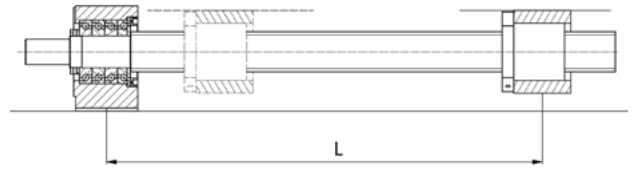

Figure 2.16 __ Bearing arrangement fixed - free

$$K_S = \frac{\pi \times d_2^2 \times E}{4 \times 10^3 \times L}$$

[Formula 2.6]

- K_S Axial rigidity of the shaft [N/ μ m]
- d_2 Core diameter [mm]
- E Modulus of elasticity [$2,06 \times 10^5$ N/mm²]
- L Unsupported shaft length [mm]

For the bearing arrangement fixed-fixed (Figure 2.17), the rigidity value is calculated according to Formula 2.7. The stiffness value reaches the minimum at the nut position $L_1 = L_2 = L / 2$.

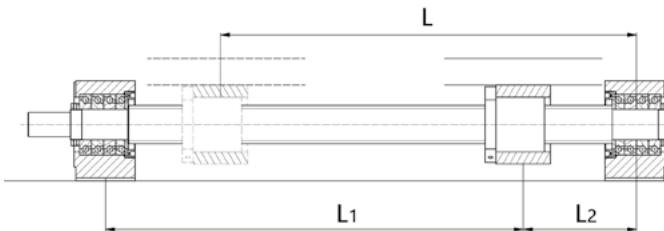

Figure 2.17 __ Bearing arrangement fixed - fixed

$$K_S = \frac{\pi \times d_2^2 \times E \times L}{4 \times 10^3 \times L_1 \times L_2}$$

[Formula 2.7]

- K_S Axial rigidity of the shaft [N/ μ m]
- d_2 Core diameter [mm]
- E Modulus of elasticity [$2,06 \times 10^5$ N/mm²]
- L Unsupported shaft length [mm]
- L_1 Distance between nut and bearing with the drive [mm]
- L_2 Distance between nut and bearing without the drive [mm]

Axial rigidity of the bearing unit K_B

The information on the axial rigidity of the bearing units in the different versions can be found in the data tables in Chapter 6.1.

Axial rigidity of the nut adaption K_A

Nut adapters are not standard parts. The axial rigidity of the nut adapter depends on the exact version. This should be designed as stiff as possible. It is for NTN-SNR not possible to specify stiffness values.

2.5.6 Static safety factor

To ensure reliable operation of a Ball Screw, it is important that the local plastic deformations of the raceways and balls under load do not exceed the permissible limit values.

The static safety factor is determined according to Formula 2.8. Under conditions of use at elevated temperatures and with ball screws made of special materials, influencing factors according to the diagrams in Figures 2.18 and 2.19 must be considered.

$$f_S = \frac{f_H \times f_T \times C_{0a}}{F_{max}}$$

[Formula 2.8]

- f_S Static safety factor
- f_H Hardness factor
- f_T Temperature factor
- C_{0a} Static load rating [kN]
- F_{max} Maximum axial load [kN]

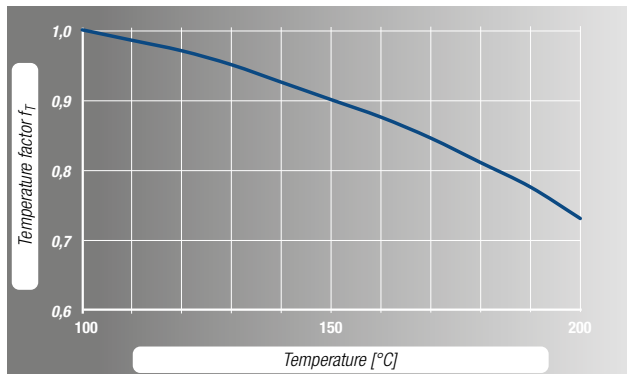

Figure 2.18 __ Temperature factor f_T

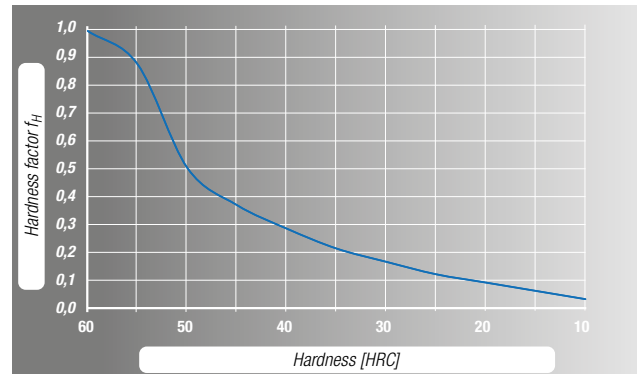

Figure 2.19 _ Hardness factor f_H

Depending on the operating conditions, recommendations for the size of the static safety factor are summarized in Table 2.17.

Table 2.17 __ Recommended values for the static safety factor

Operating condition	Static safety factor f_S
slow movement low loads no vibration and shocks	1,0...1,3
slow movement low loads light vibration and shocks	1,2...1,7
slow movement medium loads vibration and shocks	1,5...2,5
fast movement high loads vibration and shocks	2,0...4,0
fast movement high loads strong vibration and shocks	3,0...8,0

2.5.7 Service lifetime calculation

The raceways and balls of Ball Screws are exposed to loads during operation that lead to material fatigue. The nominal service lifetime L_{10} is calculated according to Formula 2.9 as the total number of revolutions of a Ball Screw until material fatigue occurs in the raceways. The influencing factors f_T and f_H (Chapter 2.5.6) must also be considered here. When calculating the nominal service lifetime L the load factor f_w is to be considered additionally. Recommendations for the load factor are given in Table 2.18.

$$L_{10} = \left(\frac{f_T \times f_H}{f_w} \times \frac{C_a}{F_m} \right)^3 \times 10^6$$

[Formula 2.9]

L_{10}	Nominal service lifetime [min ⁻¹]
f_H	Hardness factor
f_T	Temperature factor
f_w	Load factor
C_a	Dynamic load rating [kN]
F_m	Mean axial load [kN]

Table 2.18 __ Recommended values for the load factor f_w

Operating conditions	Velocity [m/s]	Load factor f_w
no or very low vibration and shocks	≤ 0,25	1,0...1,2
low vibration and shocks	0,25...≤ 1,0	1,2...1,5
medium vibration and shocks	1,0...≤ 2,0	1,5...2,0
strong vibration and shocks	> 2,0	2,0...3,5
Short stroke application		3,5...5,0

Depending on the requirements, the nominal service lifetime L can also be specified in kilometers L_s , hours L_h or number of cycles $L_{\#}$. For this purpose, the Formulas 2.10 to 2.12 are to be used.

$$L_s = \frac{L_{10} \times P}{10^6}$$

[Formula 2.10]

L_s	Nominal service lifetime [km]
L_{10}	Nominal service lifetime [min ⁻¹]
P	Pitch [mm]

$$L_h = \frac{L_{10}}{n_m \times 60 \times ED}$$

[Formula 2.11]

L_h	Nominal service lifetime [h]
L_{10}	Nominal service lifetime [min ⁻¹]
n_m	Mean operating speed [min ⁻¹]
ED	Duty cycle [%]

$$L_{\#} = \frac{L_{10} \times P}{2 \times s}$$

[Formula 2.12]

$L_{\#}$	Nominal service lifetime [cycles]
L_{10}	Nominal service lifetime [min ⁻¹]
P	Pitch [mm]
s	Travel distance [mm]

2.5.8 Bearing arrangement of Ball Screws

For the determination of the critical speed (Chapter 2.5.9) and the permissible buckling load (Chapter 2.5.11), factors resulting from the type of bearing of the ball screw drive must be used.

For both criteria, the respective free spindle length according to Figure 2.20 to 2.23 is important.

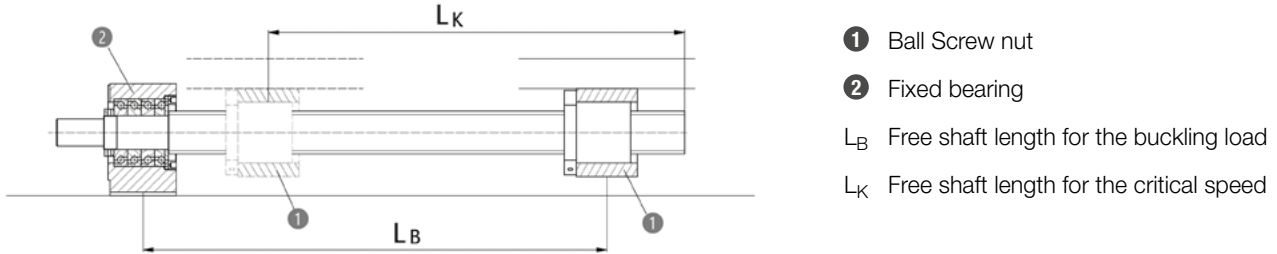

Figure 2.20 __ Bearing arrangement fixed - free

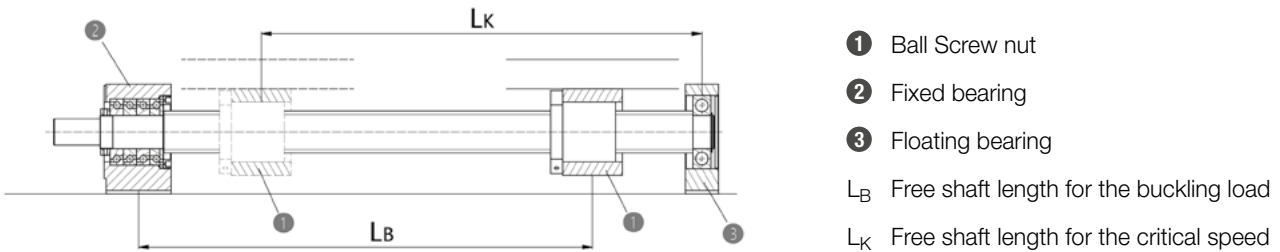

Figure 2.21 __ Bearing arrangement fixed - supported

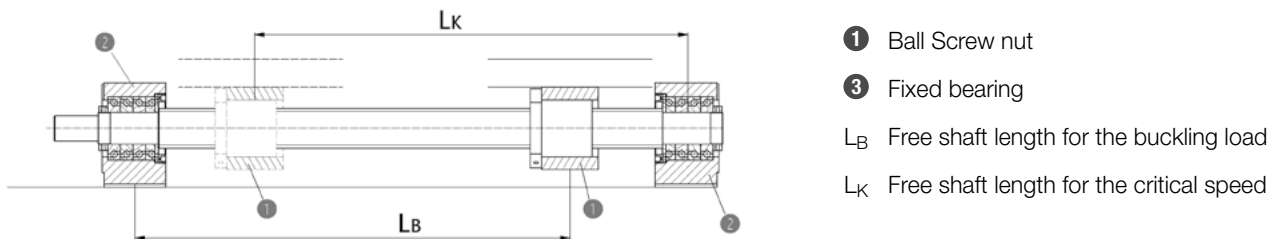

Figure 2.22 __ Bearing arrangement fixed - fixed

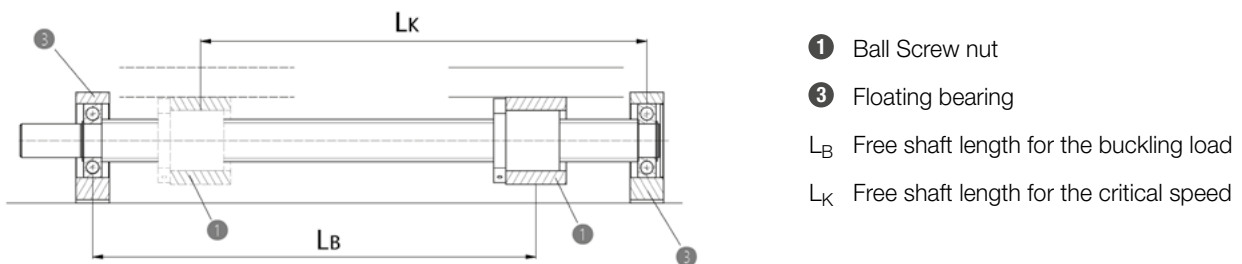

Figure 2.23 __ Bearing arrangement supported - supported

2.5.9 Critical speed

Rotating Ball Screws reach their natural frequency with increasing speed, which causes resonance vibrations that impair the function of the ball screw or destroy it. This speed is called the critical speed. The recommended maximum speed is 80% of the critical speed. This critical speed can be calculated according to Formulas 2.13 and 2.14 and the maximum permissible operating speed according to Formula 2.15. The influencing factors of the bearing arrangement are summarized in Table 2.19.

$$n_k = \frac{60 \times \lambda^2}{2 \times \pi \times l_k^2} \times \sqrt{\frac{E \times I \times 10^3}{\rho \times A}}$$

[Formulal 2.13]

$$n_k \sim f \times \frac{d_2}{l_k^2} \times 10^7$$

[Formula 2.14]

$$n_{kzul} = 0,8 \times n_k$$

[Formula2.15]

$$I = \frac{\pi}{64} \times d_2^4$$

[Formula 2.16]

$$A = \frac{\pi}{4} \times d_2^2$$

[Formula 2.17]

- n_k Critical speed [min⁻¹]
- n_{kzul} Maximum permissible operating speed [min⁻¹]
- λ, f Factor for the bearing arrangement
- l_k Free shaft length [mm]
- E Modulus of elasticity [2,06 x 10⁵ Nmm⁻²]
- I Geometrical moment of inertia (Formula 2.16) [mm⁴]
- ρ Specific material density [7,6 x 10⁻⁶ kgmm⁻³]
- A Shaft cross section (Formula 2.17) [mm²]
- d_2 Core diameter [mm]

Table 2.19 __ Influence factors of the bearing arrangement for the critical speed

fixed - free	λ	f
fixed - free	1,875	4,250
fixed - supported	3,927	18,875
fixed - fixed	4,730	27,375
supported - supported	3,140	12,125

2.5.10 DN value

In addition to the critical speed, the maximum permissible speed of a Ball Screw limited by the DN value. The permissible DN value is mainly determined by the ball circulation system of the nuts. The DN value is calculated according to Formula 2.18..

$$DN = d_{pw} \times n$$

[Formula 2.18]

- DN Speed factor [mm min⁻¹]
- d_{pw} Ball center to center diameter [mm]
- n Operating speed [min⁻¹]

2.5.11 Buckling load

Ball Screws with high axial loads, especially in vertical applications with fixed bearings at the bottom, must be dimensioned so that buckling is excluded. The recommended maximum permissible axial load is 50% of the theoretically possible axial load. The theoretically possible axial load is calculated according to Formulas 2.19 and 2.20 and the maximum permissible axial load according to Formula 2.21. The influencing factors of the bearing arrangement are summarized in Table 2.19.

$$F_k = \frac{N \times \pi^2 \times E \times I}{10^3 \times l_k^2}$$

[Formula 2.19]

F_k Theoretically possible axial load [kN]

F_{kzul} Maximal zulässige axiale Belastung [kN]

N, m Factors for the bearing arrangement

l_k Free shaft length [mm]

E Modulus of elasticity [2,06 x 10⁵ Nmm⁻²]

I Geometrical moment of inertia [mm⁴]

d₂ Core diameter [mm]

$$F_k \sim \frac{m \times d_2^4}{l_k^2} \times 10$$

[Formula 2.20]

$$F_{kzul} = 0,5 \times F_k$$

[Formula 2.21]

Table 2.20 ___ Influence factors of the bearing arrangement for the buckling load

	N	m
fixed - free	0,25	2,4
fixed - supported	2,00	20,4
fixed - fixed	4,00	40,6
supported - supported	1,00	10,2

2.5.12 Tension-compression load

In addition to the buckling load, Ball Screws must also be checked for tension - compression loads. The permissible tension - compression load is calculated according to Formula 2.22.

$$F_z = \frac{\delta \times \pi \times d_2^2}{4} = 116 \times d_2^2$$

[Formula 2.22]

F_z Permissible tension - compression load [N]

δ_s Permissible tension-compression stress [147 Nmm⁻²]

d₂ Core diameter [mm]

2.5.13 Position accuracy

The positioning accuracy of an application is determined by the sum of the errors resulting from the Ball Screw and the surrounding structure.

The following errors result from the Ball Screw:

- Pitch error
- Axial rigidity
- Axial clearance
- Thermal expansion

Pitch error

The pitch error is a value specified in accordance with DIN ISO3408-3. According to the information in Chapter 2.5.1, the suitable Ball Screw drive for the application must be determined.

Axial rigidity of the shaft

Under the action of a load, the axial rigidity directly influences the positioning accuracy. The axial rigidity of a Ball Screw depends on the position of the nut within the travel distance. The resulting error is derived from the difference between the rigidity values in the two end positions according to Formula 2.23. The rigidity values for the two end positions are calculated depending on the bearing arrangement as described in

$$e_s = \left| \frac{F_a}{K_{S1}} - \frac{F_a}{K_{S2}} \right|$$

[Formula 2.23]

- e_s Positioning error from the axial rigidity of the shaft [μm]
- F_a Axial load [N]
- K_{S1} Axial of the shaft in end position 1 [$\text{N}/\mu\text{m}$]
- K_{S2} Axial of the shaft in end position 1 [$\text{N}/\mu\text{m}$]

Axial clearance of the Ball Screw

Axial clearance does not affect the positioning accuracy with uniform movement in one direction. If the load direction is changed or the direction of movement is reversed, the backlash causes a positioning error. For this reason, the Ball Screw must be selected to match the application with axial clearance, without axial clearance or with preload. Information on this is contained in Chapter 5.1.4.

Thermal expansion

Changes in temperature during the operation of Ball Screws lead to expansion or shortening of the shaft, which changes the positioning accuracy. The Ball Screw drive heats up, especially at high speeds. If there are very high demands on the positioning accuracy, measures must be taken to reduce the generation of heat. The following measures are possible here:

- Select the preload as low as possible
- Reduction of the speed by selecting a larger pitch
- Suitable lubricants
- Cooling of the Ball Screw by air or lubricant

The thermal change in length of a shaft can be determined according to Formula 2.24.

$$\Delta L = \alpha \times \Delta T \times L$$

[Formulat 2.24]

- ΔL Change in length of a shaft [μm]
- α Thermal expansion coefficient [$12 \times 10^{-3}/^\circ\text{C}$]
- ΔT Temperature change [$^\circ\text{C}$]
- L Effective thread length [mm]

Surrounding structure

In order to determine the positioning accuracy of a force application point of an application, the horizontal and vertical tilting of the surrounding structure must be considered in addition to the axial error resulting from the Ball Screw. The resulting angular errors are to be projected onto the force application point.

2.5.14 Drive power

The necessary drive torque of a spindle drive for converting rotary to linear movement can be calculated according to Formula [2.25]. An acting axial force can also generate a linear movement that is converted into a rotary movement by the spindle drive. The generated output torque is calculated according to Formula [2.26]. The corresponding efficiency can be taken from the diagrams in Figure 7 and Figure 8 in Chapter 1.3.1. The pitch angle is calculated according to Formula [2.27].

$$T_a = \frac{F_a \times P}{2\pi \times \eta_1}$$

[Formula 2.25]

$$T_e = \frac{F_a \times P \times \eta_2}{2\pi}$$

[Formula 2.26]

$$\tan \beta = \frac{P}{\pi \times d_{pw}}$$

[Formula 2.27]

T_a	Input torque [Nm]
T_e	Output torque [Nm]
F_a	Axial load [kN]
P	Pitch [mm]
η	Efficiency
η_1	Efficiency when converting rotary to linear movement
η_2	Efficiency when converting linear to rotary motion
β_a	Pitch angle [°]
d_{pw}	Ball center to center diameter [mm]

The input and output torque calculated here refer only to the ball screw. For the exact calculation of the input or output torque, additional influencing factors must be included. These influencing factors are the friction coefficient of the bearing units, the mass moments of inertia, the idling torque resulting from the seals and the preload.

3. Assembling

3.1 Transport and storage

Ball screws are high-quality machine elements and must be handled with appropriate care. To avoid damage and pollution, they should remain in the protective film until installation. For longer storage, we recommend leaving the products in the NTN-SNR transport packaging to prevent the Ball Screw from bending or radial loads on the nut. Suitable and tested lifting devices must be used to handle longer and heavier Ball Screws. There should be several support points (Figure 3.1) over the length of the Ball Screw in order to limit the bending.

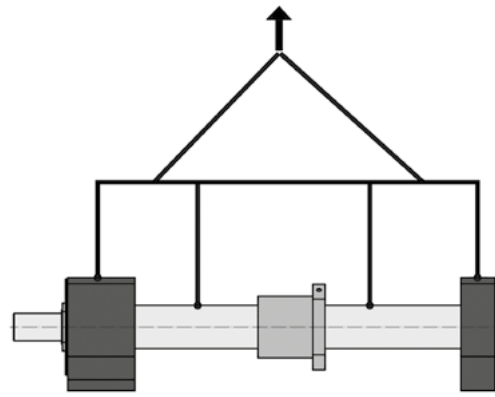

Figure 3.1 ___ Transport of Ball Screws

During transport, the Ball Screw nuts must be secured with e.g. cable ties (Figure 3.2) to prevent them from moving on their own.

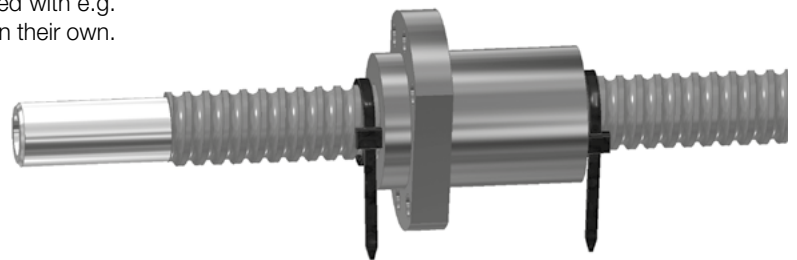

Figure 3.2 ___ Securing of Ball Screw nuts

3.2 Assembly tolerances

Construction notes

Ball Screws are high-quality machine elements that have a significant influence on the accuracy and service lifetime of the entire system.

Surrounding structure and assembly tolerances

Ball Screws are only suitable for the transmission of axial loads. Radial loads and moments (e.g. due to tilted installation) represent undefined loads and lead to premature failure (Figure 3.3).

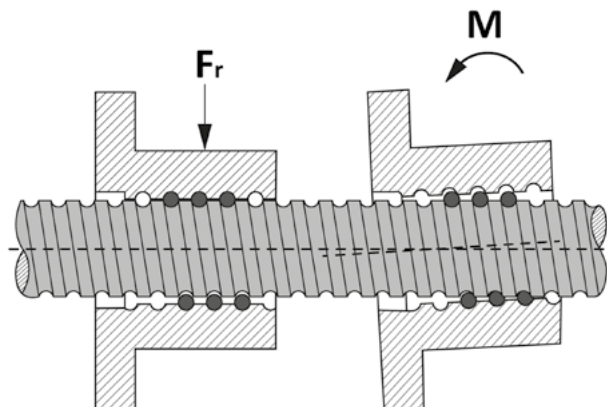

Figure 3.3 ___ Impermissible loads on Ball Screws

In principle, the following applies: the higher the accuracy and preload of the Ball Screw, the more precisely the surrounding structure must be manufactured. This is especially important for applications in which the nut is moved to end position, as the risk of tension and thus additional loads is very high in this area.

Assembly tolerances

When using ball screws, the following assembly tolerances are given as shown in Figure 3.4:

- Perpendicularity of the surrounding structure to the shaft center line
- Height offset ΔH of the bearings to each other
- Side offset ΔA of the bearings to each other

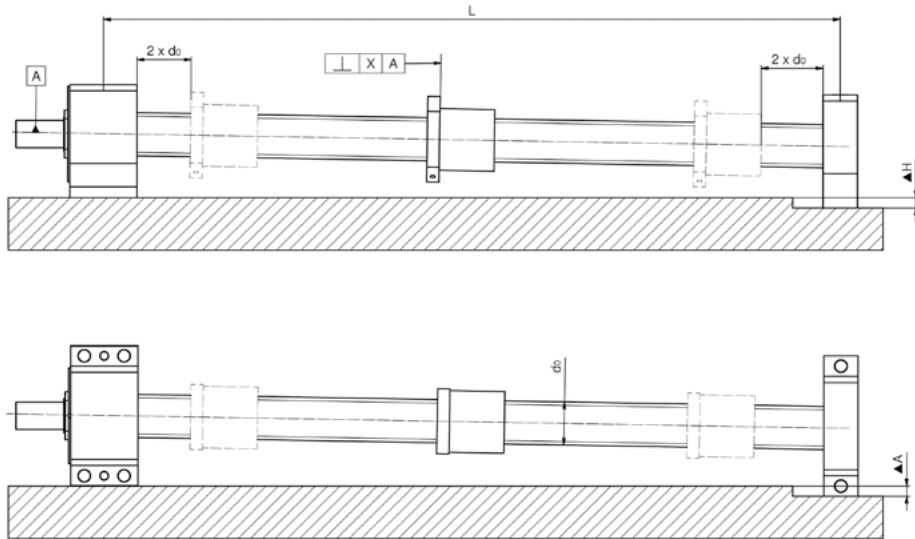

Figure 3.4 ___ Definition of the assembly tolerances of Ball Screws

The diagram in Figure 3.5 shows the recommended installation tolerances for Ball Screws depending on the length and the preload class. When designing the surrounding structure, these tolerances must be observed. The values apply to a minimum distance between the nut and the bearings of $\geq 2x$ nominal diameter d_0 of the shaft.

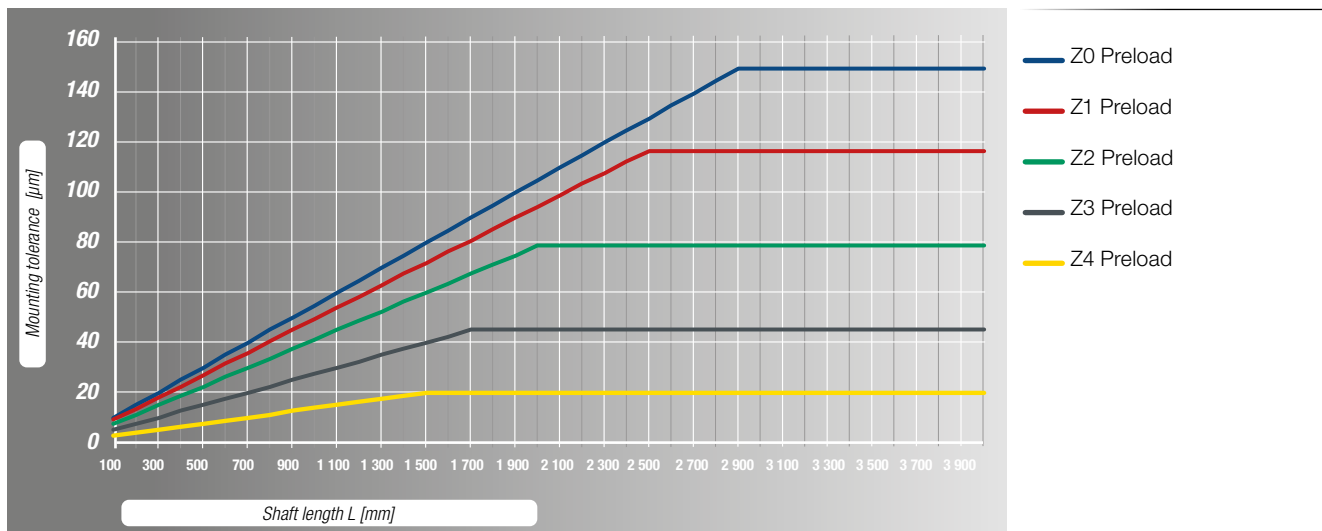

Figure 3.5 ___ Assembly tolerances of Ball Screws

3.3 Assembly instructions

3.3.1 Assembly of Ball Screw nuts

SNR Ball Screws should, if possible, be delivered with the nut assembled on the shaft and including end machining in order to avoid assembly on site.

Shafts and nuts delivered separately do not have a defined preload or a defined axial clearance. This must be adapted during assembly by ball selection, which is usually not possible on the customer side.

Separate nuts for Ball Screws are supplied on assembly sleeves and secured with cable ties (Figure 3.6).

Ball Screw nuts may only be installed by people who are familiar with them. Suitable tools and devices are to be used for the work (Figure 3.7).

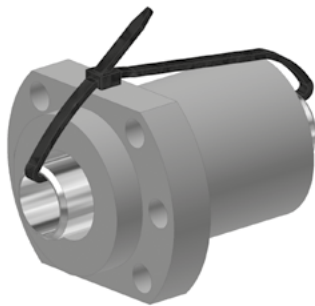

Figure 3.6 ___ Separate nut from Ball Screws

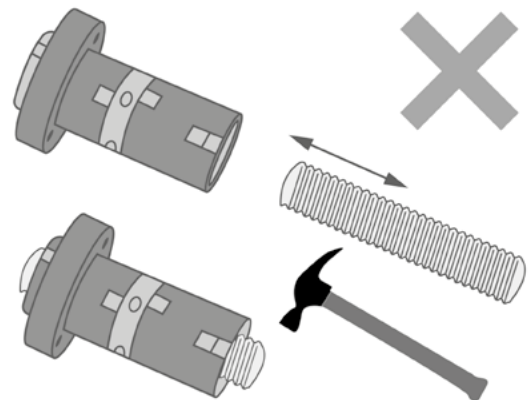

Figure 3.7 ___ Errors in the assembly of Ball Screw nuts

When assembling Ball Screw nuts, proceed according to the following steps (Figure 3.8):

Remove the cable tie that holds the assembly sleeve **3** in the nut **1**.



After removing the cable tie, make sure that the nut does not protrude beyond the end of the assembly sleeve - risk of ball loss!

In the case of double nuts, make sure that the nut halves are not separated from each other!

- Slide the assembly sleeve **3** with the nut **1** over an end machining until the beginning of the thread. The assembly sleeve **3** must be full axial contact and aligned concentrically.
- Turn nut **1** with slight axial pressure on shaft **2**. If you feel resistance, turn the nut back and repeat the process.
- The assembly sleeve **3** may only be removed when the nut **2** is completely on the shaft thread **2**.

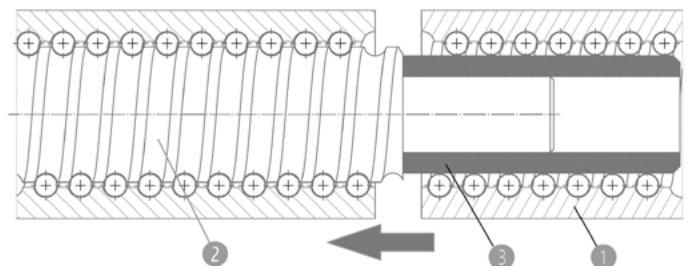

Figure 3. ___ Assembly of Ball Screw nuts

If subsequent machining on the shaft by the customer is unavoidable, the nut must first be removed from the shaft. The original mounting sleeve must be used for this. The work steps must be carried out in reverse order as described above. If there is no mounting sleeve, an alternative can be made. The outer diameter of the sleeve should be approx. 0.1 mm smaller than the core diameter of the shaft. The shaft should be straightened after machining or checked for shape and position tolerances (Chapter 2.5.2).

3.3.2 Assembly of fixed bearings

When assembling the bearings of a Ball Screw on the bearing journal of the shaft, the assembly load may only be applied via the inner ring. If there is a clearance fit or a light transition fit, the bearing can be slid on manually. If the actual oversize is too great, we recommend the use of suitable assembly tools such as the SNR assembly case or manual or hydraulic presses. A slight warming of the bearing can be helpful here.

The Ball Screw spindle must be firmly clamped for assembly. Shorter Ball Screws can be assembled vertically; longer ones can only be assembled horizontally.

The removal of anti-corrosion fluids on the surfaces of bearings and shafts is generally not necessary.

3.3.2.1 Assembly of bearings type BST

The NTN bearings for ball screws of the BST series are axial angular contact ball bearings. In order to be able to easily recognize the installation position, these bearings are equipped with two different coloured seals. If the black seals are on the outside, the bearings have a DB arrangement. The precision nut required for assembly is not included in the delivery. We recommend the use of precision nuts type PRS (Chapter 6.1.1.5).

When assembling, proceed according to the following steps (Figure 3.7):

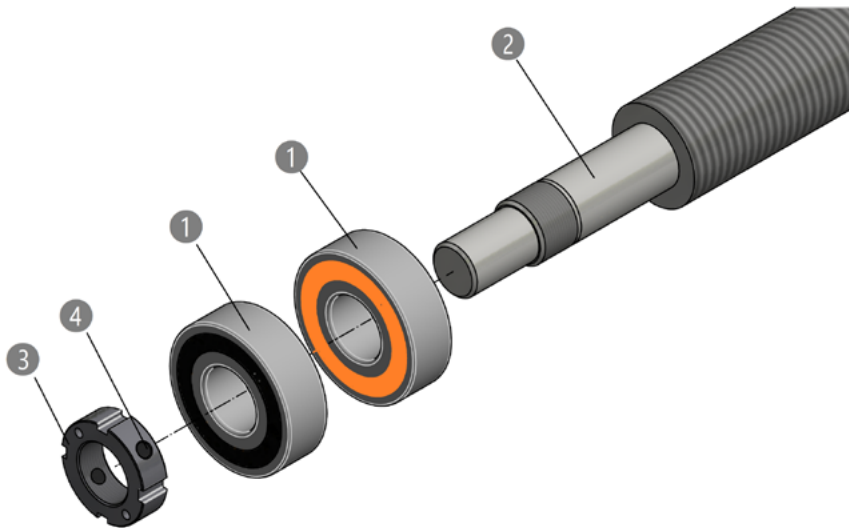

Figure 3.9 ___ Assembly of axial angular contact ball bearings type BST

- Push the BST bearings ① manually with slight axial pressure or with an assembly tool onto the shaft end ②. The correct arrangement of the bearings must be ensured.
- Screw the precision nut PRS ③ onto the fastening thread with the ground surface first and tighten it over the radial grooves with the torque M_a specified in Chapter 6.1.1.5, Table 6.13.
- To secure the precision nut ③, tighten the radial set screws ④ with the torque M_{bl} specified in Chapter 6.1.1.5, Table 6.13.

3.3.2.2 Assembly of fixed bearing units' type BSTK

These BSTK bearing units are supplied greased and assembled. Only the precision nut PRS for axial securing on the shaft is included loose. The bearing units should not be disassembled any further.

When assembling the BSTK bearing units, proceed according to the following steps (Figure 3.10):

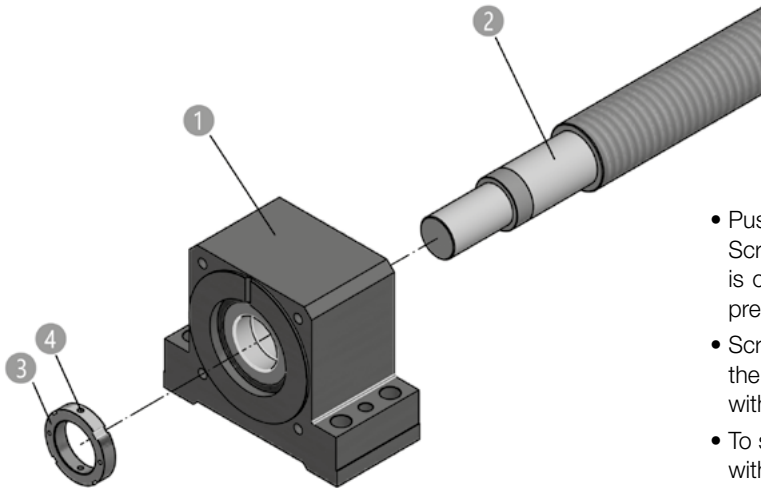

- Push the bearing unit **1** with the threaded ring facing the Ball Screw **2** onto the bearing seat until the inner ring of the bearing is completely in contact with the shaft shoulder, if necessary, press it on with a suitable assembly tool.
- Screw the precision nut PRS **3** onto the fastening thread with the ground surface first and tighten it over the radial grooves with the torque M_a specified in Chapter 6.1.1.5, Table 6.13.
- To secure the precision nut **3**, tighten the radial set screws **4** with the torque M_{bl} specified in Chapter 6.1.1.5, Table 6.13.

Figure 3.10 __ Assembly of fixed bearing units' type BSTK

3.3.2.3 Assembly of fixed bearing units type BSTU

The NTN bearings of the BSTU series are double-row axial angular contact ball bearings, which have been specially developed for Ball Screws. The outer rings of two axial angular contact ball bearings are combined to a unit and which contains the assembling holes. The precision nut required for assembly is not included in the delivery. We recommend the use of precision nuts type PRS (Chapter 6.1.1.5).

When assembling the BSTU bearing units, proceed according to the following steps (Figure 3.11):

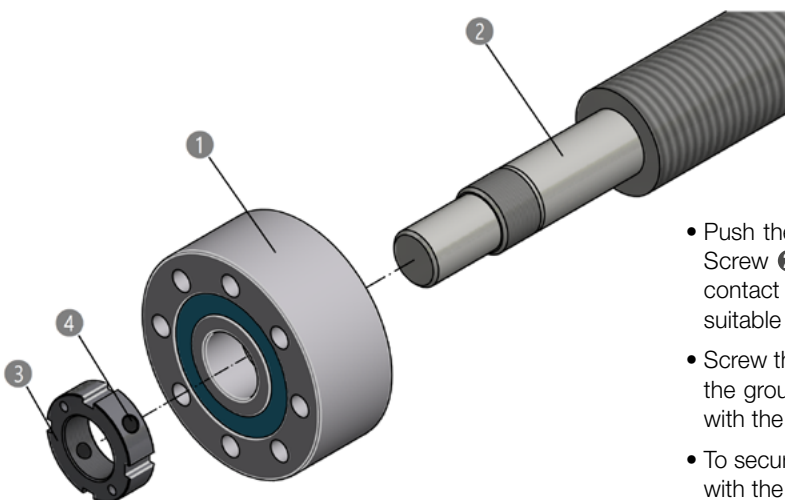

- Push the BSTU bearings **1** onto the bearing seat of the Ball Screw **2** until the inner ring of the bearing is completely in contact with the shaft shoulder, if necessary, press on with a suitable assembly tool.
- Screw the precision nut PRS **3** onto the fastening thread with the ground surface first and tighten it over the radial grooves with the torque M_a specified in Chapter 6.1.1.5, Table 6.13.
- To secure the precision nut **3**, tighten the radial set screws **4** with the torque M_{bl} specified in Chapter 6.1.1.5, Table 6.13.

Figure 3.11 __ Assembly of fixed bearing units' type BSTU

3.3.2.4 Assembly of fixed bearing units type BK, EK and FK

The BK, EK and FK bearing units are supplied greased and assembled. Only the precision nut PRN for axial securing on the shaft and two spacer rings are included loose. The bearing units should not be disassembled any further.

When assembling the bearing units BK, EK and FK, proceed according to the following steps (Figure 3.12):

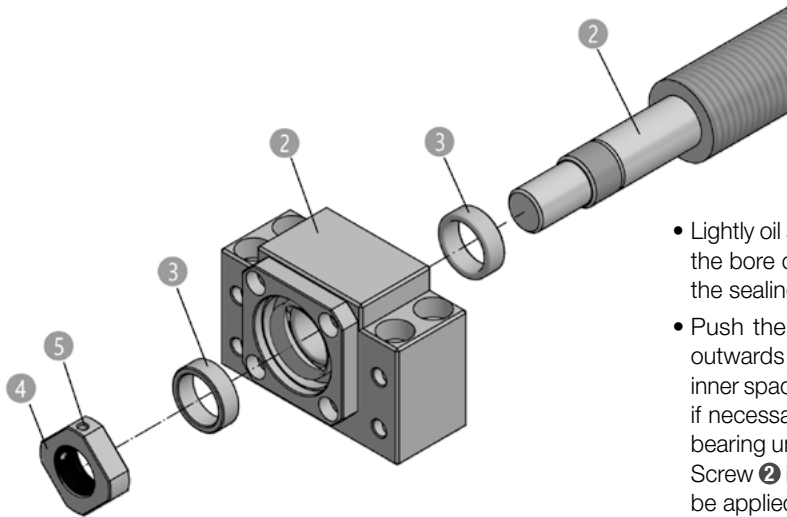

Figure 3.12 __ Assembly of bearing units BK, EK and FK

- Lightly oil spacer rings **3** and carefully insert them sideways into the bore of the seals of the bearing units **1** without damaging the sealing lips.
- Push the bearing unit BK and EK **1** with the cover facing outwards onto the bearing seat of the Ball Screw **2** until the inner spacer ring is completely in contact with the shaft shoulder, if necessary, press it on with a suitable assembly tool. The FK bearing units are to be pushed onto the bearing seat of the Ball Screw **2** in the required installation position. The force may only be applied via the outer spacer ring **3**.
- Screw the precision nut PRN **4** onto the fastening thread with the ground surface first and tighten with the torque M_a specified in Chapter 6.1.2.5, Table 6.20.
- To secure the precision nut **4**, tighten the radial set screws **5** with the torque M_{bl} specified in Chapter 6.1.2.5, Table 6.20.

3.3.3 Assembly of floating bearings and floating bearing units

The floating bearing units BSTF, BF, EF and FF are supplied greased and assembled. Only the locking ring is included loosely.

When assembling the bearing units BSTF, BF, EF and FF, proceed according to the following steps (Figure 3.13):

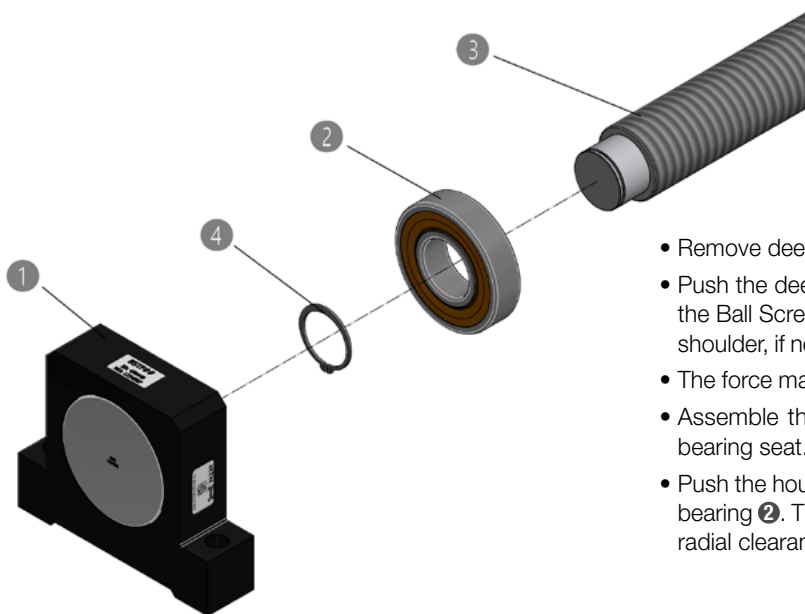

Figure 3.13 __ Assembly of floating bearing units type BSTF, BF, EF and FF

- Remove deep groove ball bearing **2** from housing **1**.
- Push the deep groove ball bearing **2** onto the bearing seat of the Ball Screw **3** until it is completely in contact with the shaft shoulder, if necessary, press it on with a suitable assembly tool.
- The force may only be applied via the inner ring of the bearing.
- Assemble the circlip **4** in the corresponding groove in the bearing seat.
- Push the housing **1** over the outer ring of the deep groove ball bearing **2**. This must be easy to move axially without excessive radial clearance.

3.3.4 Assembly of Ball Screws in machines

The following basic rules must be observed when assembling Ball Screws in machines:

- For long shafts, the instructions from Chapter 3.1 must be observed.
- All assembling surfaces of the surrounding structure must be clean and free of burrs.
- During assembly, the ball screw drive must be aligned parallel to the existing guides. The assembling tolerances in Chapter 3.2 must be observed.

We recommend the following assembly sequence:

- ▶ Align the fixed and floating bearings as well as the nut and fix it slightly.
- ▶ Move the slider as far as possible to the fixed bearing and first screw the fixed bearing to the machine bed, then screw the nut to the slider.
- ▶ Move the slider as far as possible to the floating bearing and first screw this to the machine bed.
- ▶ A different assembly sequence may be necessary depending on the structural design.
- ▶ If it is necessary to disassemble the nut from the shaft, a assembling sleeve must be used to avoid losing of balls. This disassembling may only be carried out by qualified staff, taking into account the information in Chapter 3.3.2.
- ▶ The tightening torques permitted for the respective material pairing are not exceeded for all screw connections.
- ▶ If the torque is constant over the entire stroke after assembly and is within the permissible limit values according to Chapter 2.5.3, the Ball Screw is precisely aligned. If there are deviations, an optimization can be achieved by realigning it in the end positions.
- ▶ Nuts supplied separately do not have an initial greasing and must be greased according to the information in Chapter 4.5 before being used for the first time.
- ▶ For assembled Ball Screws, we recommend lubrication with the amount specified for relubrication in Chapter 4.5 before start-up.

4. Maintenance and lubrication

4.1 General information

**Attention!**

All maintenance and service work on the Ball Screws must be carried out when it is switched off and secured.

4.2 Lubrication

An adequate lubrication is essential for the reliable function of ball screws.

The lubrication should ensure a lubricating film (oil film) between the rolling elements and the raceways of the guiding and drive elements to prevent wear and premature fatigue of the components.

In addition, the metallic surfaces are protected from corrosion. Furthermore, the lubricating film enables the seals to slide smoothly over the surfaces and reduces their wear.

Insufficient lubrication not only increases wear, it also significantly shortens the service life.

An optimal selection of the lubricant has a decisive influence on the function and service life of the Ball Screw. So that the function is not impaired and is maintained over a long period of time, lubrication must be defined according to the environmental conditions and the specific requirements.

Such environmental conditions and influencing factors can e.g. be:

- High or low temperature
- Effects of condensation and water splash
- Radiation exposure
- Strong vibrations
- Use in vacuum and / or clean rooms
- Application of special media (e.g. vapors, acids, etc.)
- High acceleration and velocity
- Permanent short stroke movement ($< 2 \times$ nut length)
- Effect of dirt or dust

The recommendations in the following chapters enable the selection of the suitable lubricant, the required amount of lubricant and the definition of the lubrication interval.

These recommendations do not release the user from checking the specified lubrication intervals under the specific operating conditions in the application and adjusting them if necessary.

4.3 Lubricants

Different lubricants are suitable for lubrication of Ball Screws. The lubricants must fulfill the following tasks:

- Reduction of friction
- Reduction of the starting torque
- Protection against premature wear
- Protection against corrosion
- Noise reduction

For use under normal conditions, lithium soap greases with the classification KP2-K according to DIN 51825 and NLGI class 2 according to DIN 51818 with EP additives must be used. SNR LUB HEAVY DUTY is used as the standard grease.

**Attention!**

Lubricants with solid additives (e.g. graphite or MoS_2) are not suitable.

Specific requirements under special environmental conditions require the selection of a suitable lubricants. Basically, the compatibility of the lubricants with one another or with the anti-corrosion oil must be checked.

4.3.1 Anti-corrosion oils

Anti-corrosion oils serve to protect the Ball Screws against corrosion during storage and transport. They are not suitable for lubrication of the Ball Screws during operation.

During start-up and re-lubrication, the compatibility with the existing lubricant must always be checked.

SNR Ball Screws are supplied with the anti-corrosion oil Contrakor Fluid H1. Contrakor Fluid H1 is compatible with the standard lubricant SNR LUB HEAVY DUTY. Preservation may be omitted by agreement for special applications with special lubricants.

4.3.2 Lubrication oils

Oil lubrication is usually applied in central lubrication systems. The advantage of an automated, central oil lubrication is that of operator-independent, continuous lubricant supply to the Ball Screw. Lubrication oils also conduct friction heat very well. This is balanced against a very high design and installation effort for lubrication tubes. Lubrication oil also leaks more often from the Ball Screw and is thus lost to the system.

Tilted or vertical arrangements with the Ball Screw nut lubrication connection on the bottom are critical and should be avoided.

Suitable lubrication oils for use in SNR Ball Screws are summarized in Table 4.1.

Table 4.1 ___ Lubrication oils for Ball Screws

Description	Oil type	Kinematic viscosity according to DIN51562 at 40°C [mm ² /s]	Density [mg/cm ³]	Properties	Application area
Klüberoil GEM 1-100N	Mineral oil	100	880	<ul style="list-style-type: none"> · Good corrosion protection · Good wear protection 	<ul style="list-style-type: none"> · General engineering
Klüberoil 4 UH1-68N	Polyalpha- olefin	680	860	<ul style="list-style-type: none"> · Good wearing protection · Good ageing resistance · NSF H1 registered* 	<ul style="list-style-type: none"> · Food industry · Pharmaceutical industry

** This lubricant has been registered as an H1 product, i.e. it was developed for occasional, technically unavoidable contact with food. Experience has shown that the lubricant can also be used for appropriate applications in the pharmaceutical and cosmetic industry when the conditions in the product information are adhered to. However, no specific test results that might be required for applications in the pharmaceutical industry, e.g. biocompatibility, are available. The systems manufacturer and operator should therefore, perform appropriate risk analyses before applications in this area. Measures to exclude health risks and injuries have to be taken, where required.*

(Source: Klüber Lubrication)

4.3.3 Low-viscosity greases

The conditions that apply to the use of lubrication oils also apply to the use of low-viscosity greases. Only the tilted or vertical installation position is not critical here, since low-viscosity greases with their lower viscosity do not flow away so easily.

Suitable low-viscosity greases for use in SNR Ball Screws are summarized in in Table 4.2.

Table 4.2____ Low-viscosity greases for Ball Screws

Description	Base oil / Type of soap	NLGI class DIN51818	Walkpenetration DIN ISO 2137 at 25°C [0,1mm]	Basic oil viscosity DIN 51562 at 40°C [mm ² /s]	Density [mg/cm ³]	Properties	Application area
Isoflex Topas NCA 5051	Synthetic hydrocarbon oil, special calcium soap	0/00	385...415	30	800	· Low friction	· General engineering
Microlobe GB 0"	Mineral oil	0	355...385	400	900	· Particularly pressure resistant · Good wearing protection properties · Very good water resistance	· General engineering · High loads · Short stroke application · Vibrations
Klübersynth UH1 14-1600	Synthetic hydrocarbon oil, special Aluminum complex soap Polyurea	0/00	370...430	ca. 160	850	· Good corrosion protection · Good wear protection · NSF H1 registered*	· Food industry · Pharmaceutical industry

** This lubricant has been registered as an H1 product, i.e. it was developed for occasional, technically unavoidable contact with food. Experience has shown that the lubricant can also be used for appropriate applications in the pharmaceutical and cosmetic industry when the conditions in the product information are adhered to. However, no specific test results that might be required for applications in the pharmaceutical industry, e.g. biocompatibility, are available. The systems manufacturer and operator should therefore, perform appropriate risk analyses before applications in this area. Measures to exclude health risks and injuries have to be taken, where required.*

(Source: Klüber Lubrication)

4.3.4 Lubrication greases

Ball screws with grease lubrication are used in most applications. The use of greases provides better noise reduction, better emergency running properties and requires less constructive effort than lubrication oils and low-viscosity greases. For use under normal conditions, lithium soap greases with the classification KP2-K according to DIN 51825 and NLGI class 2 according to DIN 51818 with EP additives must be used. SNR LUB HEAVY DUTY is used as the standard grease.

Specific requirements under special environmental conditions require the selection of a suitable lubricants. Basically, the compatibility of the lubricants with one another or with the anti-corrosion oil must be checked.

Suitable lubrication greases for use in SNR Ball Screws are summarized in in Table 4.3.

Table 4.3 ___ Lubrication greases for Ball Screws

Description	Base oil / Type of soap	NLGI class DIN51818	Walkpenetration DIN ISO 2137 at 25°C [0,1mm]	Basic oil viscosity DIN 51562 at 40°C [mm ² /s]	Density [mg/cm ³]	Properties	Application area
SNR LUB HEAVY DUTY	Mineral oil / Lithium with EP additives	2	295	app. 115	890	· very high protection against wear and corrosion	· General engineering · High loads
SNR LUB HIGH SPEED+	Ester, SHC / Lithium, Calcium	2	-	25	900	· Very good adhesion properties · Very good water resistance	· High velocity
SNR LUB HIGH TEMP	semi-synthetic oil / Polyurea	2	265...295	160	900	· High temperature resistance · Good corrosion protection · High oxidation resistance	· High temperature range
SNR LUB FOOD AL	Paraffinic mineral oil, PAO / Aluminum complex	2	265...295	248	877	· Good corrosion protection · Very good adhesion properties · High water resistance · NSF H1 registered*	· Food industry
Microlube GL261	Mineral oil / special Lithium-calcium soap	1	310...340	280	890	· Good wearing protection · Particularly pressure resistant additives against tribocorrosion	· General engineering · High loads · Short stroke application · Vibrations
Klübersynth BEM34-32	Synthetic hydrocarbon oil / special calcium soap	2	265...295	app. 30	890	· Particularly pressure resistant · Good wearing protection · Good ageing resistance · Low starting torque"	· Clean room application
Klübersynth UH1 14-151	Synthetic hydrocarbon oil / ester oil Aluminum complex soap	1	310...340	app. 150	920	· Good corrosion protection · Good ageing resistance · High water resistance · NSF H1 registered*	· Food industry · Pharmaceutical industry

* Dieser Schmierstoff ist als H1-Produkt registriert, d.h. er wurde für den gelegentlichen, technisch unvermeidbaren Kontakt mit Lebensmitteln entwickelt. Erfahrungen haben gezeigt, dass der Schmierstoff unter den in der Produktinformation aufgeführten Voraussetzungen auch für entsprechende Anwendungen in der pharmazeutischen und kosmetischen Industrie verwendet werden kann. Es liegen jedoch keine spezifischen Testergebnisse z.B. zur Biokompatibilität vor, wie sie unter Umständen für Anwendungen im pharmazeutischen Bereich gefordert werden. Daher sollten vor Anwendung in diesem Bereich vom Anlagenhersteller und -betreiber entsprechende Risikoanalysen durchgeführt werden. Bei Bedarf sind Maßnahmen zum Ausschluss von gesundheitlicher Gefährdung und Verletzungen zu treffen.

(Quelle: Klüber Lubrication)

4.4 Lubrication methods

SNR Ball Screws can be supplied with lubricant by manual grease guns or central lubrication systems.

In the case of cylindrical nuts, this lubrication hole (Figure 4.1) must be led to a grease nipple via a lubrication channel in the nut housing. Flange type nuts have a threaded hole in the flange (Figure 4.2) to which a grease nipple can be mounted directly.

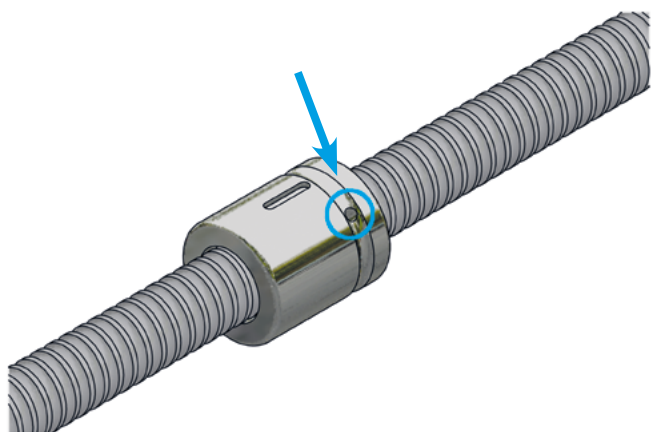

Figure 4.1 ___ Cylindrical nut with lubrication hole

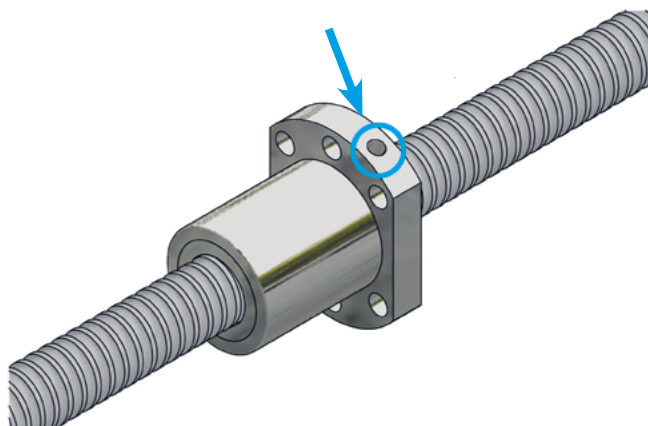

Figure 4.2 ___ Flange type nut with threaded hole

4.4.1 Manual grease gun – SNR - LUB GREASE GUN SET

Ball Screws can be re-lubricated with the SNR manual grease gun (LUB GREASE GUN SET ID number 273018). The LUB GREASE GUN SET includes the manual grease gun, a flexible hose and a nozzle for hydraulic type grease nipples.

The manual grease gun can be operated with one hand. Cartridges or unpackaged greases can be picked up. The grease gun was developed for industrial use with a maximum pressure of 360 bar. A small, controlled amount of grease of 0.5 cm³ is conveyed per stroke.

When using manual grease guns (Figure 4.3), the nut of the Ball Screw drive is re-lubricated via a lubrication hole.



Figure 4.3 ___ SNR - LUB GREASE GUN SET

4.4.2 Central lubrication system

SNR Ball Screws can be connected to a central lubrication system.

Suitable centralized lubrication systems are SNR-LUBER-CONTROL (Figure 4.4) and SNR-POLYPUMP (Figure 4.5).

SNR – LUBER-CONTROL has six connections for lubrication tubes that can be parameterized individually. Optionally, CONTROL REFILL units with 250 cm³ and 500 cm³ lubricant volume can be used. The CONTROL REFILL unit can be exchanged after emptying or refilled factory provided.

SNR-POLYPUMP is a powerful central lubrication system that is easy to set up. It enables to lubricate 1 to 35 lubrication points at the same time in the simplest possible way. Various lubrication points can be supplied with different amounts of a lubricant with one system via pump elements. The storage container can easily be filled with standard refill cartridges. The connection to the existing machine control is quick and easy.



Figure 4.4 ___ SNR-LUBER-CONTROL



Figure 4.5___ SNR-POLYPUMP

4.5 Lubricant amounts

The respective minimum lubrication amount for Ball Screws depend on the type of lubricant, nut type and size.

During maintenance of Ball Screws, a distinction between:

- Lubrication during start-up
- Re-lubrication during operation

Nuts supplied separately for SNR Ball Screws are preserved with anti-corrosion oil on delivery and do not have an initial lubrication. Fully assembled Ball Screws are supplied with initial greasing, unless nothing else has been specified.

Tables 4.4 to 4.11 contain the minimum lubricant amount of the various lubricants for start-up and with which SNR Ball Screws are to be re-lubricated during operation. The corresponding amount of lubricant is to be supplied in 3 ... 4 small partial amounts with the nut moving in the meantime over at least twice the nut length.

Differing amounts of lubricant can be determined depending on the operating conditions.

Miniature Ball Screws with a diameter of less than 12 mm are only suitable for oil lubrication.

Our NTN-SNR application engineers are available for further information.

Table 4.4____ Lubrication amount for Ball Screw nuts type CD

Type	Grease lubrication		Liquid grease lubrication		Oil lubrication	
	Initial greasing [cm ³]	Re-greasing [cm ³]	Initial greasing [cm ³]	Re-greasing [cm ³]	Initial greasing [ml]	Re-greasing [ml]
BNU01605_CD_5	1,8	0,9	1,8	0,9	0,36	0,07
BNU01610_CD_2	1,8	0,9	1,8	0,9	0,36	0,07
BNU01616_CD_1	1,8	0,9	1,8	0,9	0,36	0,07
BNU02005_CD_4	2,1	1,1	2,1	1,1	0,42	0,08
BNU02020_CD_2	4,5	2,3	4,5	2,3	0,90	0,18
BNU02505_CD_4	3,2	1,6	3,2	1,6	0,63	0,13
BNU02510_CD_3	3,9	1,9	3,9	1,9	0,77	0,15
BNU02525_CD_2	6,2	3,1	6,2	3,1	1,25	0,25
BNU03205_CD_5	4,3	2,2	4,3	2,2	0,86	0,17
BNU03210_CD_5	6,9	3,5	6,9	3,5	1,39	0,28
BNU03220_CD_2	6,9	3,5	6,9	3,5	1,39	0,28
BNU03232_CD_2	10,1	5,0	10,1	5,0	2,02	0,40

Table 4.5 ____ Lubrication amount for Ball Screw nuts CI

Type	Grease lubrication		Liquid grease lubrication		Oil lubrication	
	Initial greasing [cm ³]	Re-greasing [cm ³]	Initial greasing [cm ³]	Re-greasing [cm ³]	Initial greasing [ml]	Re-greasing [ml]
BNU01205_CI_3	1,0	0,5	1,0	0,5	0,17	0,03
BNU01604_CI_4	1,6	0,8	1,6	0,8	0,32	0,06
BNU01605_CI_4	1,8	0,9	1,8	0,9	0,36	0,07
BNU02004_CI_4	2,0	1,0	2,0	1,0	0,40	0,08
BNU02005_CI_4	2,3	1,1	2,3	1,1	0,45	0,09
BNU02504_CI_4	2,8	1,4	2,8	1,4	0,56	0,11
BNU02505_CI_4	3,2	1,6	3,2	1,6	0,63	0,13
BNU02510_CI_4	6,0	3,0	6,0	3,0	1,19	0,24
BNU03204_CI_4	3,6	1,8	3,6	1,8	0,72	0,14
BNU03205_CI_4	4,1	2,0	4,1	2,0	0,81	0,16
BNU03210_CI_4	7,7	3,8	7,7	3,8	1,53	0,31
BNU04005_CI_4	5,4	2,7	5,4	2,7	1,08	0,22
BNU04010_CI_4	17,0	8,5	17,0	8,5	3,40	0,68
BNU05010_CI_4	23,8	11,9	23,8	11,9	4,76	0,95
BNU06310_CI_4	23,8	11,9	23,8	11,9	4,76	0,95
BNU08010_CI_4	34,0	17,0	34,0	17,0	6,80	1,36

Table 4.6 ____ Lubrication amount for Ball Screw nuts DC

Type	Grease lubrication		Liquid grease lubrication		Oil lubrication	
	Initial greasing [cm ³]	Re-greasing [cm ³]	Initial greasing [cm ³]	Re-greasing [cm ³]	Initial greasing [ml]	Re-greasing [ml]
BNU01605_DC_3	2,9	1,5	2,9	1,5	0,58	0,12
BNU01610_DC_2	3,9	1,9	3,9	1,9	0,78	0,16
BNU02005_DC_3	3,8	1,9	3,8	1,9	0,75	0,15
BNU02010_DC_3	6,0	3,0	6,0	3,0	1,20	0,24
BNU02505_DC_3	5,3	2,6	5,3	2,6	1,05	0,21
BNU02510_DC_3	8,5	4,3	8,5	4,3	1,71	0,34
BNU03205_DC_3	7,4	3,7	7,4	3,7	1,48	0,30
BNU03210_DC_3	11,0	5,5	11,0	5,5	2,20	0,44
BNU03220_DC_2	14,4	7,2	14,4	7,2	2,88	0,58
BNU04005_DC_3	10,2	5,1	10,2	5,1	2,04	0,41
BNU04010_DC_3	24,6	12,3	24,6	12,3	4,92	0,98
BNU04020_DC_2	32,4	16,2	32,4	16,2	6,48	1,30
BNU05005_DC_3	15,3	7,7	15,3	7,7	3,06	0,61
BNU05010_DC_3	33,1	16,6	33,1	16,6	6,62	1,32
BNU05020_DC_3	61,0	30,5	61,0	30,5	12,21	2,44

Table 4.7 ____ Lubrication amount for Ball Screw nuts SC

Type	Grease lubrication		Liquid grease lubrication		Oil lubrication	
	Initial greasing [cm ³]	Re-greasing [cm ³]	Initial greasing [cm ³]	Re-greasing [cm ³]	Initial greasing [ml]	Re-greasing [ml]
BNU01205_SC_2	0,9	0,5	0,9	0,5	0,15	0,03
BNU01210_SC_2	1,4	0,7	1,4	0,7	0,23	0,05
BNU01605_SC_3	1,5	0,7	1,5	0,7	0,30	0,06
BNU01610_SC_2	1,9	0,9	1,9	0,9	0,38	0,08
BNU01616_SC_1	1,8	0,9	1,8	0,9	0,36	0,07
BNU01616_SC_2	2,4	1,2	2,4	1,2	0,49	0,10
BNU01620_SC_1	2,3	1,1	2,3	1,1	0,46	0,09
BNU02005_SC_3	0,9	1,9	0,9	0,4	0,07	0,18
BNU02010_SC_3	1,4	2,9	1,4	0,6	0,11	0,46
BNU02020_SC_1	1,6	3,2	1,6	0,6	0,13	0,52
BNU02020_SC_2	2,3	4,6	2,3	0,9	0,18	0,86
BNU02505_SC_3	2,6	1,3	2,6	1,3	0,52	0,10
BNU02510_SC_3	4,0	2,0	4,0	2,0	0,80	0,16
BNU02525_SC_1	4,6	2,3	4,6	2,3	0,91	0,18
BNU02525_SC_2	6,7	3,3	6,7	3,3	1,33	0,27
BNU03205_SC_3	3,8	1,9	3,8	1,9	0,76	0,15
BNU03210_SC_3	5,4	2,7	5,4	2,7	1,08	0,22
BNU03220_SC_2	7,2	3,6	7,2	3,6	1,44	0,29
BNU03232_SC_1	7,4	3,7	7,4	3,7	1,48	0,30
BNU03232_SC_2	10,4	5,2	10,4	5,2	2,09	0,42
BNU04005_SC_3	5,4	2,7	5,4	2,7	1,08	0,22
BNU04010_SC_3	12,6	6,3	12,6	6,3	2,52	0,50
BNU04020_SC_2	16,4	8,2	16,4	8,2	3,28	0,66
BNU04040_SC_1	21,0	10,5	21,0	10,5	4,20	0,84
BNU04040_SC_2	29,0	14,5	29,0	14,5	5,80	1,16
BNU05005_SC_3	8,1	4,1	8,1	4,1	1,62	0,32
BNU05010_SC_3	16,3	8,2	16,3	8,2	3,26	0,65
BNU05020_SC_3	25,9	13,0	25,9	13,0	5,18	1,04
BNU05050_SC_1	30,0	15,0	30,0	15,0	6,00	1,20
BNU05050_SC_2	30,0	15,0	30,0	15,0	6,00	1,20

Table 4.8 ____ Lubrication amount for Ball Screw nuts SH

Type	Grease lubrication		Liquid grease lubrication		Oil lubrication	
	Initial greasing [cm ³]	Re-greasing [cm ³]	Initial greasing [cm ³]	Re-greasing [cm ³]	Initial greasing [ml]	Re-greasing [ml]
BNU00802.5_SH_2					0,05	0,01
BNU01002_SH_3					0,07	0,01
BNU01004_SH_2					0,10	0,02
BNU01204_SH_3	1,0	0,5	1,0	0,5	0,17	0,03
BNU01205_SH_3	1,2	0,6	1,2	0,6	0,20	0,04
BNU01404_SH_3	1,4	0,7	1,4	0,7	0,28	0,06
BNU01604_SH_3	1,3	0,6	1,3	0,6	0,26	0,05
BNU01605_SH_3	1,7	0,8	1,7	0,8	0,34	0,07
BNU02005_SH_3	2,3	1,1	2,3	1,1	0,45	0,09
BNU02505_SH_4	4,8	2,4	4,8	2,4	0,97	0,19

Table 4.9___ Lubrication amount for Ball Screw nuts SK

Type	Grease lubrication		Liquid grease lubrication		Oil lubrication	
	Initial greasing [cm ³]	Re-greasing [cm ³]	Initial greasing [cm ³]	Re-greasing [cm ³]	Initial greasing [ml]	Re-greasing [ml]
BNU00601_SK_3					0,02	0,00
BNU00801_SK_4					0,03	0,01
BNU00802_SK_3					0,03	0,01
BNU00802.5_SK_3					0,05	0,01
BNU01002_SK_3					0,08	0,02
BNU01004_SK_3					0,10	0,02
BNU01202_SK_4	0,8	0,4	0,8	0,4	0,14	0,03
BNU01204_SK_3	0,8	0,4	0,8	0,4	0,14	0,03
BNU01205_SK_3	0,8	0,4	0,8	0,4	0,14	0,03
BNU01402_SK_4	0,8	0,4	0,8	0,4	0,14	0,03

Table 4.10___ Lubrication amount for Ball Screw nuts SU

Type	Grease lubrication		Liquid grease lubrication		Oil lubrication	
	Initial greasing [cm ³]	Re-greasing [cm ³]	Initial greasing [cm ³]	Re-greasing [cm ³]	Initial greasing [ml]	Re-greasing [ml]
BNU01605_SU_4	1,8	0,9	1,8	0,9	0,36	0,07
BNU01610_SU_3	2,3	1,1	2,3	1,1	0,46	0,09
BNU02005_SU_4	2,6	1,3	2,6	1,3	0,51	0,10
BNU02505_SU_4	3,6	1,8	3,6	1,8	0,71	0,14
BNU02510_SU_4	5,6	2,8	5,6	2,8	1,12	0,22
BNU03205_SU_4	4,7	2,3	4,7	2,3	0,94	0,19
BNU03210_SU_4	7,7	3,8	7,7	3,8	1,53	0,31
BNU04005_SU_4	6,6	3,3	6,6	3,3	1,32	0,26
BNU04010_SU_4	17,6	8,8	17,6	8,8	3,52	0,70
BNU05010_SU_4	21,1	10,6	21,1	10,6	4,22	0,84
BNU06310_SU_4	26,0	13,0	26,0	13,0	5,21	1,04
BNU06320_SU_4	39,0	25,0	39,0	25,0	7,30	1,60
BNU08010_SU_4	37,2	18,6	37,2	18,6	7,44	1,49
BNU08020_SU_4	55,0	27,0	55,0	27,0	11,00	2,30

Table 4.11 Lubrication amount for Ball Screw nuts TW

Type	Grease lubrication		Liquid grease lubrication		Oil lubrication	
	Initial greasing [cm ³]	Re-greasing [cm ³]	Initial greasing [cm ³]	Re-greasing [cm ³]	Initial greasing [ml]	Re-greasing [ml]
BNU01605_TW_4	3,0	1,5	3,0	1,5	0,60	0,12
BNU02005_TW_4	4,3	2,1	4,3	2,1	0,85	0,17
BNU02505_TW_4	6,0	3,0	6,0	3,0	1,20	0,24
BNU02510_TW_4	9,1	4,6	9,1	4,6	1,82	0,36
BNU03205_TW_4	7,8	3,9	7,8	3,9	1,57	0,31
BNU03210_TW_4	13,1	6,5	13,1	6,5	2,61	0,52
BNU04005_TW_4	10,8	5,4	10,8	5,4	2,16	0,43
BNU04010_TW_4	29,6	14,8	29,6	14,8	5,92	1,18
BNU05010_TW_4	35,5	17,8	35,5	17,8	7,10	1,42
BNU06310_TW_4	42,8	21,4	42,8	21,4	8,57	1,71
BNU08010_TW_4	61,2	30,6	61,2	30,6	12,24	2,45

4.6 Lubrication intervals

The re-lubrication intervals are influenced by many factors (Chapter 4.2). The greatest influence usually has the load and the existing contamination. Exact re-lubrication intervals can only be determined after determination under real operating conditions and assessment over a sufficiently long period for a specific application.

The diagrams in Figures 4.5 and 4.6 serve as a guideline for determining the re-lubrication interval under normal pollution conditions for Ball Screws with low-viscosity grease or grease lubrication.

The re-lubrication intervals are shown as the number of revolutions ($s_{\#}$) of the Ball Screw as a function of the ratio of the mean axial load (F_m) to the dynamic load rating (C_a) for the respective nominal diameter (d_0).

Under real operating conditions, it is easier to determine the re-lubrication interval according to the mileage in kilometers than according to the number of revolutions.

The mileage in kilometers is calculated using the Formula [4.1].

$$s = \frac{s_{\#} \times P}{10^6}$$

[Formula 4.1]

- s** Re-lubrication interval [km]
- $s_{\#}$** Re-lubrication interval [revolution]
- P** Pitch [mm]

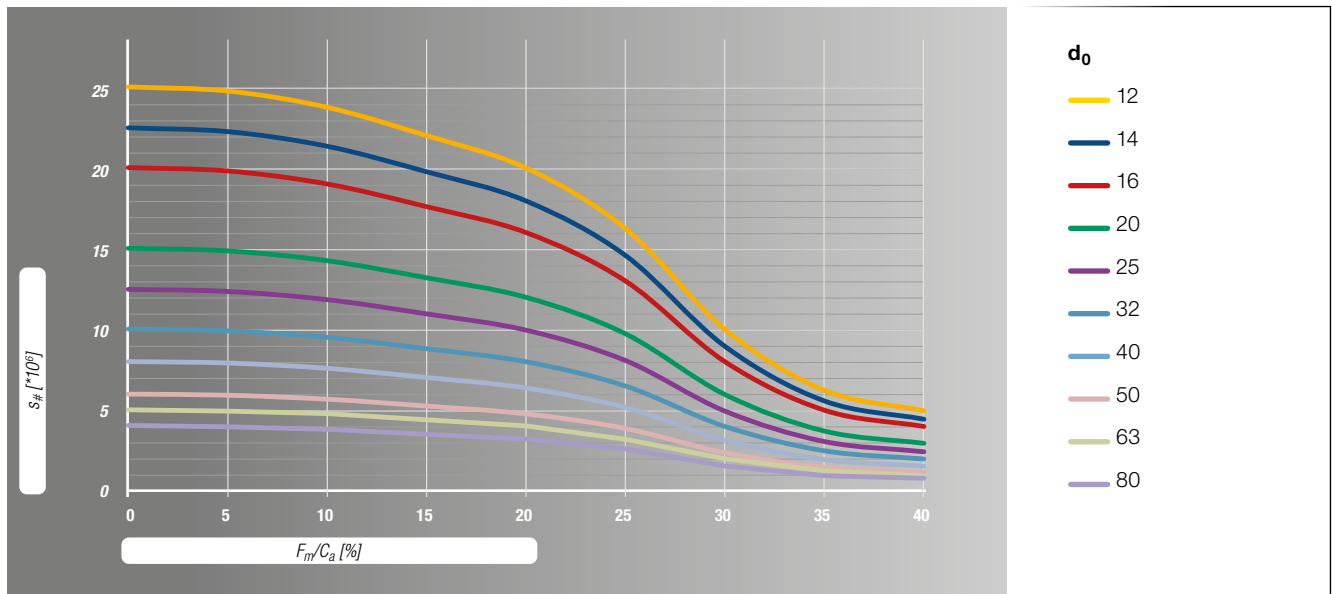

Figure 4.6 ___ Re-lubrication interval for Ball Screws with grease lubrication

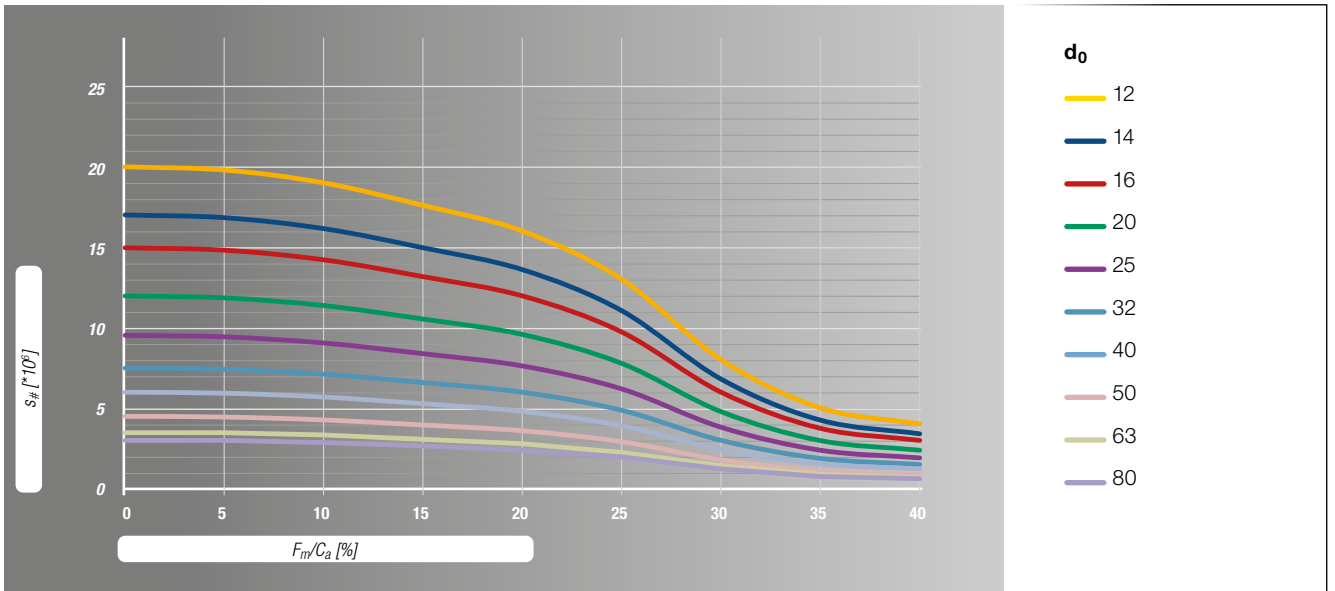

Figure 4.7 ___ Re-lubrication interval for Ball Screws with low-viscosity grease lubrication

The diagram in Figures 4.7 serve as a guideline for determining the re-lubrication interval under normal pollution conditions for Ball Screws with oil lubrication.

In addition to the re-lubrication interval as the number of revolutions ($s_{\#}$), the re-lubrication interval in operating hours (s_h) must also be considered for oil lubrication because the oils with little movements flow out by gravity from the contact area. The criterion that is reached first determines the re-lubrication interval.

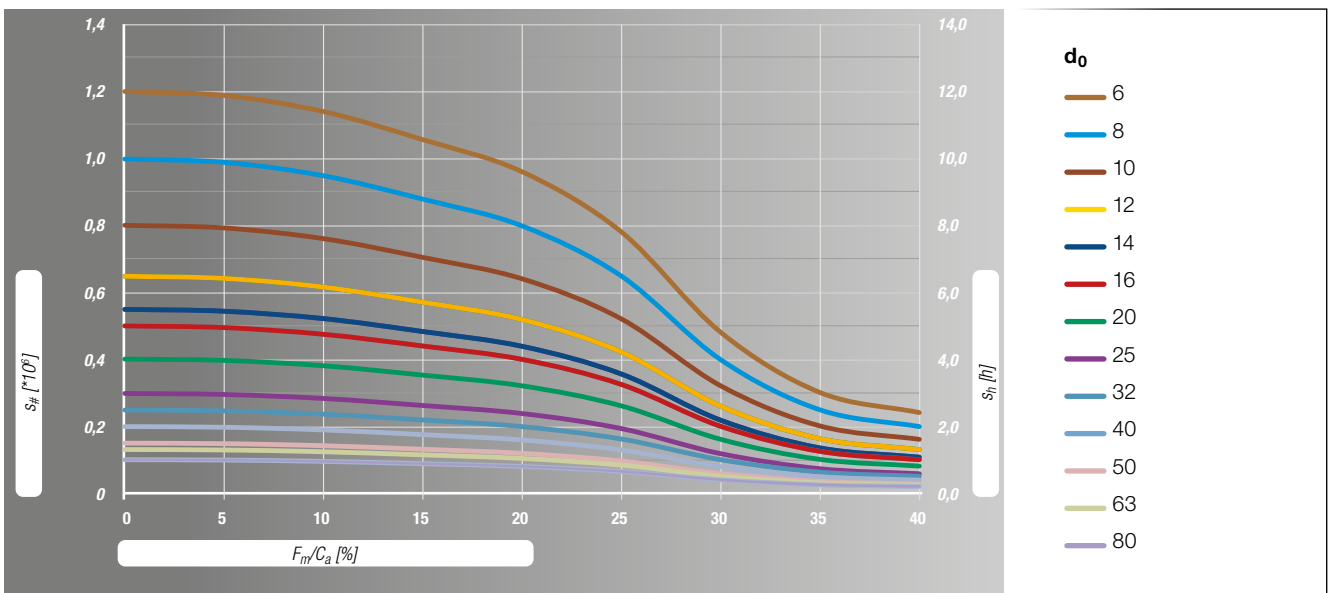

Figure 4.8 ___ Re-lubrication interval for Ball Screws with oil lubrication

Here, too, the mileage in kilometers can be calculated using the Formula [4.1]. If the operating hours (s_h) are the first criterion that occurs, the number of revolutions ($s_{\#}$) on the opposite axis must be used for the calculation.

For short stroke applications ($\text{stroke} \leq \text{nut length}$) it is recommended to shorten the re-lubrication intervals.

Our NTN-SNR application engineers are available for further information.

5. SNR Ball Screws

5.1 Versions and options

5.1.1 Nut types

NTN-SNR offers a wide range of Ball Screws with different nut types. For the user, the selection options result in optimal solutions for the requirements from all areas of industry.

The most important features of the nut types are summarized below.

SC nut

- Dimension according DIN 69051
- Single nut
- Flange type B as standard
- Compact design
- High DN value

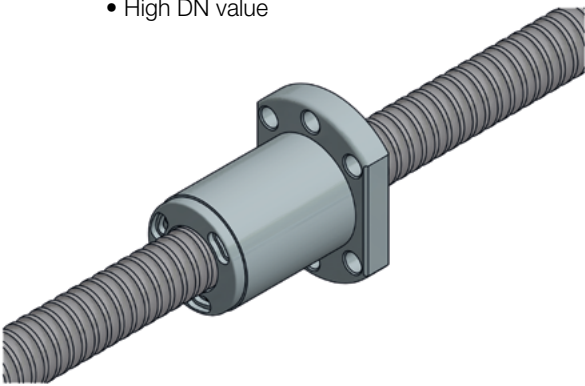

DC nut

- Dimension according DIN 69051
- Double nut
- Flange type B as standard
- Compact design
- High DN value

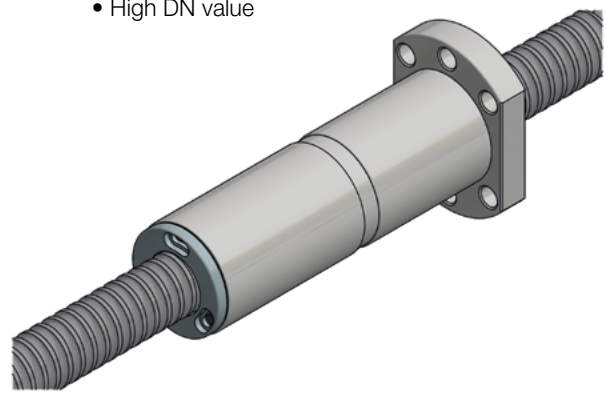

SU nut

- Dimension according DIN 69051
- Single nut
- Flange type B as standard
- High load ratings
- High rigidity

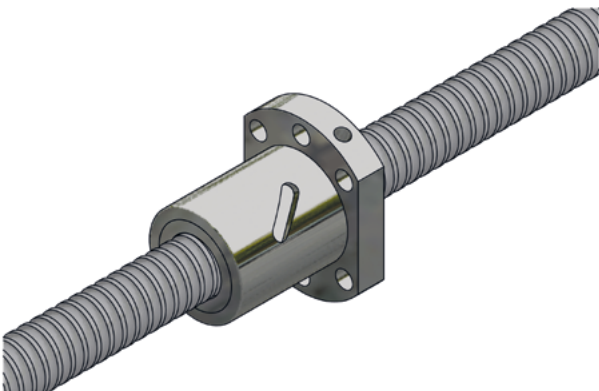

TW nut

- Dimension according DIN 69051
- Single nut with pitch offset
- Flange type B as standard
- High load ratings
- High rigidity

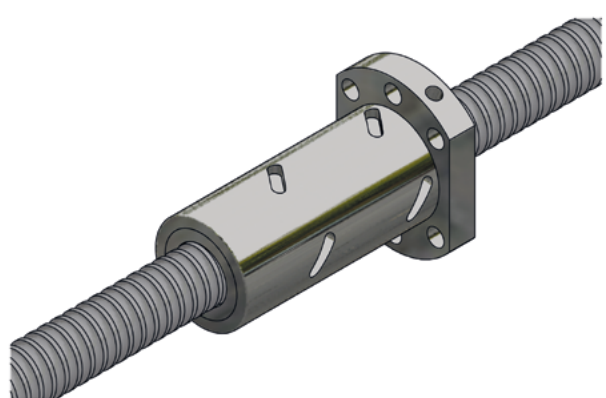

CD nut

- Single nut
- Compact cylindrical design
- High DN value

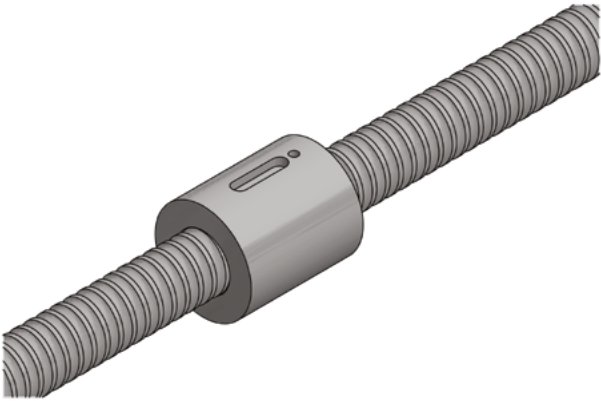

CI nut

- Single nut
- Cylindrical design
- High load ratings
- High rigidity

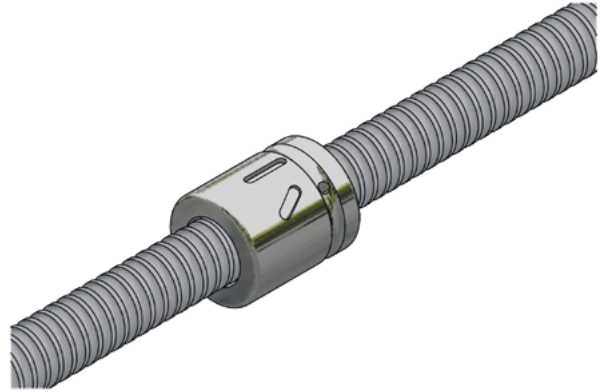

SH nut

- Single nut
- Nut body with external thread on the face side for direct assembly in the connection components

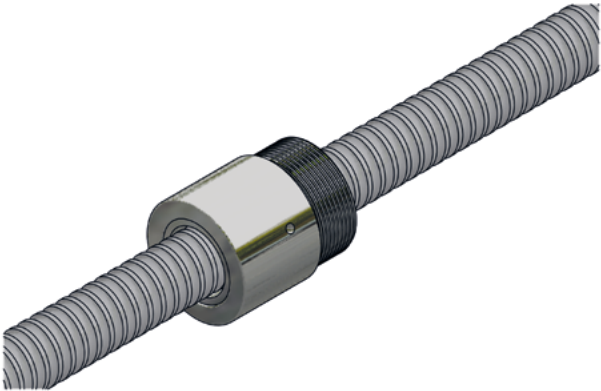

SK nut

- Miniature single nut
- Flange type B as standard
- Extremely compact design

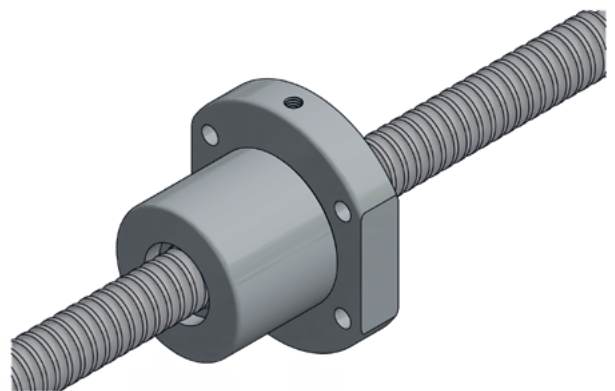

5.1.2 Main parameter

Ball Screw nuts according DIN 69051

Table 5.1 ____ Main parameter of Ball Screw nuts according DIN 69051

Nut type	Design type	Nominal diameter d_0 [mm]	Pitch P [mm]	Dynamic load rating C_a [kN]	Static load rating C_{0a} [kN]
DC	Compact double nut	16...50	5...20	10,9...56,4	24,6...181,3
SC	Compact single nut	12...50	5...50	5,7...50,7	10,0...163,2
SU	Single nut	16...80	5...10	9,4...114,0	21,2...421,4
TW	Single nut with pitch offset	16...80	5...10	13,5...72,0	29,9...313,4

Cylindrical Ball Screw nuts

Table 5.2 ____ Main parameter of cylindrical Ball Screw nuts

Nut type	Design type	Nominal diameter d_0 [mm]	Pitch P [mm]	Dynamic load rating C_a [kN]	Static load rating C_{0a} [kN]
CD	Compact single nut	16...32	5...32	5,4...29,5	11,2...90,2
CI	Single nut	12...80	4...10	3,0...72,0	5,0...313,4
SH	Screw-in nut	8...25	2...5	1,9...16,9	3,7...48,1

Miniature Ball Screw nuts

Table 5.3 ____ Main parameter of miniature Ball Screw nuts

Nut type	Design type	Nominal diameter d_0 [mm]	Pitch P [mm]	Dynamic load rating C_a [kN]	Static load rating C_{0a} [kN]
SK	Miniature nut with flange	6...14	1...4	1,1...4,6	2,2...10,3

5.1.3 Correction factors for load ratings

The information about the load ratings of Ball Screw nuts in Chapter 5.2 are related to an optimal load distribution on all loaded balls for Ball Screws of the tolerance class 5. According to DIN ISO 3408-5, correction factors for the dynamic and static axial load rating are to be considered depending on the tolerance class. With the correction factors from Table 5.4, the modified load ratings are calculated according Formulas 5.1 and 5.2.

$$C_{0am} = C_{0a} \times f_{ac}$$

[Formula 5.1]

C_{0am} Modified static load rating [kN]

C_{0a} Static load rating [kN]

f_{ac} Load rating correction factor

$$C_{am} = C_a \times f_{ac}$$

[Formula 5.2]

C_{0am} Modified dynamic load rating [kN]

C_{0a} Dynamic load rating [kN]

f_{ac} Load rating correction factor

Table 5.4 ____ Correction factors for load ratings

Nut type	Tolerance class		
	0, 1, 3, 5	7	10
Correction factor f_{ac}	1,0	0,9	0,7

5.1.4 Dimension shaft versions

SNR Ball Screws can be produced as rolled, whirled or ground versions. The same nut types are used for all versions. The rolled and whirled shafts are standard products, grinded shafts on request.

5.1.4.1 Rolled shafts

Rolled SNR Ball Screw shafts are produced as standard in tolerance class T7. The dimension, maximum production length and possible combinations with the standard nuts are shown in Figure 5.1 and summarized in Table 5.5.

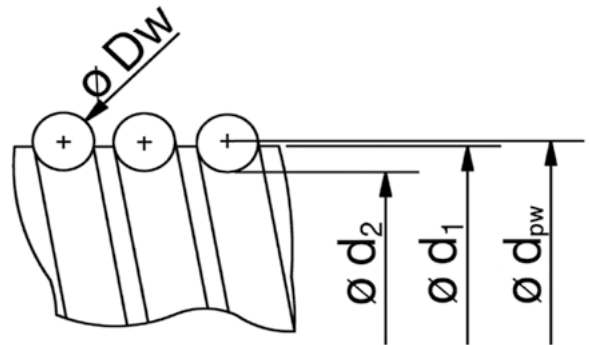

Figure 5.1 ____ Dimension of rolled shafts

Table 5.5 ____ Dimension of rolled shafts

Shaft type	Nominal diameter d_0 [mm]	Nut type						Ball center to center diameter d_{pw} [mm]	Outer diameter d_1 [mm]	Root diameter d_2 [mm]	Mass m [kg/m]	Maximum length [mm]
		SK	CI	CD	SC	SU	SH					
BSH00601_00	6	x						6,27	6,0	5,47	0,19	1 000
BSH00801_00	8	x						8,20	8,0	7,40	0,37	1 000
BSH00802_00		x						8,41	8,0	7,21	0,39	
BSH00802.5_00		x					x	8,41	8,0	7,21	0,39	
BSH01002_00	10	x					x	10,41	10,0	9,21	0,59	3 100
BSH01004_00		x					x	10,68	10,0	8,68	0,58	
BSH01202_00		x						12,41	12,0	11,21	0,85	
BSH01204_00	12						x	12,30	12,0	9,80	0,75	3 100
BSH01205_00				x			x	12,30	12,0	9,80	0,80	
BSH01205_01					x			12,30	12,0	9,80	0,78	
BSH01210_01					x			12,30	12,0	9,80	0,78	
BSH01402_00	14	x						14,41	14,0	13,21	1,17	3 100
BSH01404_00							x	14,85	14,0	12,14	1,10	
BSH01604_00							x	16,82	16,0	14,44	1,47	
BSH01605_00	16		x			x	x	17,08	16,0	13,90	1,42	3 100
BSH01605_01				x	x			15,67	15,0	12,89	1,27	
BSH01610_00							x	17,08	16,0	13,90	1,51	
BSH01610_01					x	x		15,67	15,0	12,89	1,31	
BSH01616_01					x	x		15,67	15,0	12,89	1,35	
BSH01620_01						x		15,67	15,0	12,89	1,36	
BSH02005_00	20		x				x	21,08	20,0	17,90	2,29	3 100
BSH02005_01				x	x			21,08	20,0	17,90	2,29	
BSH02010_01						x		21,08	20,0	17,90	2,35	
BSH02020_01					x	x		20,76	20,0	17,59	2,36	
BSH02505_00	25		x				x	26,08	25,0	22,90	3,60	6 100
BSH02505_01				x	x			26,08	25,0	22,90	3,60	
BSH02510_00			x				x	26,62	25,0	21,86	3,52	
BSH02510_01					x	x		26,08	25,0	22,90	3,73	
BSH02525_01					x	x		26,08	25,0	22,91	3,79	
BSH03205_00	32		x				x	33,08	32,0	29,90	6,00	6 100
BSH03205_01				x	x			33,08	32,0	29,90	6,00	
BSH03210_00			x				x	34,15	32,0	27,80	5,65	
BSH03210_01					x	x		32,35	31,0	28,38	5,67	
BSH03220_01					x	x		32,35	31,0	28,38	5,79	
BSH03232_01					x	x		32,35	31,0	28,38	5,83	
BSH04005_00	40		x				x	41,08	40,0	37,90	9,32	6 100
BSH04005_01						x		41,08	40,0	37,90	9,32	
BSH04010_00			x				x	42,15	40,0	35,80	9,05	
BSH04010_01						x		39,52	38,0	33,17	8,05	
BSH04020_01						x		39,52	38,0	33,17	8,33	
BSH04040_01						x		39,52	38,0	33,17	8,66	
BSH05010_00	50		x				x	52,15	50,0	45,80	14,17	6 100
BSH05005_01						x		51,10	50,0	47,92	14,91	
BSH05010_01						x		50,15	48,0	43,81	13,20	
BSH05020_01						x		50,15	48,0	43,81	13,63	
BSH05050_01						x		50,15	48,0	43,81	13,63	
BSH06310_00	63		x				x	65,15	63,0	58,80	23,19	7 100
BSH06320_00							x	66,25	63,0	56,72	22,72	
BSH08010_00	80		x				x	82,15	80,0	75,80	37,33	7 100
BSH08020_00							x	83,25	80,0	73,72	37,12	

5.1.4.2 Whirled shafts

Whirled SNR Ball Screw shafts are produced as standard in tolerance classes T5 and P5. It is also possible to produce whirled Ball Screw shafts in tolerance classes T3 and P3 on request. The dimension, maximum production length, production process-related maximum thread length and possible combinations with the standard nuts are shown in Figure 5.2 and summarized in Table 5.6.

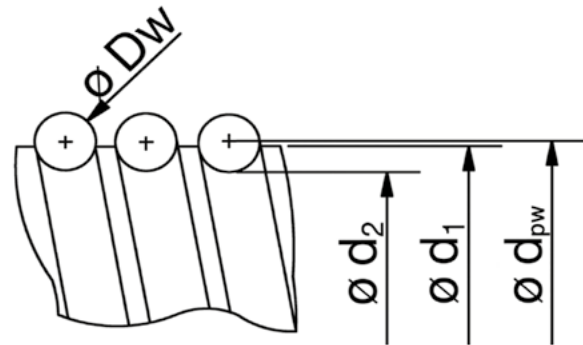

Figure 5.2 Dimension whirled shafts

Table 5.6 Dimension whirled shafts

Shaft typ	Nominal diameter d_0 [mm]	Nut type									Ball center to center diameter d_{pw} [mm]	Outer diameter d_1 [mm]	Root diameter d_2 [mm]	Mass m [kg/m]	Maximum length [mm]	
		SK	CI	CD	SC	DC	SU	TW	SH							
BSH00801_00	8	x									8,19	8h6	7,40	0,37	2 400	
BSH00802_00		x									8,41		7,22	0,39		
BSH00802.5_00		x								x			8,41	7,22		0,39
BSH01002_00	10	x									10,41	10h6	9,22	0,59	2 400	
BSH01004_00		x								x			10,68	8,48		0,58
BSH01202_00	12	x									12,41	12h6	11,22	0,85	2 400	
BSH01204_00											12,30		9,58	0,75		
BSH01205_00				x									12,85	10,13		0,80
BSH01205_01					x								12,28	9,80		0,78
BSH01210_01						x							12,30	9,80		0,83
BSH01402_00	14	x									14,41	14h6	13,22	1,17	2 400	
BSH01404_00											14,85		12,13	1,10		
BSH01604_00											x		16,82	14,21		1,47
BSH01605_00	16		x								17,08	16h6	13,60	1,42	5 400	
BSH01605_01				x	x	x			x	x	x		15,66	12,64		1,27
BSH01610_00											x		17,08	13,60		1,51
BSH01610_01					x	x	x						15,68	12,64		1,31
BSH01616_01					x	x							15,69	12,64		1,35
BSH01620_01						x							15,66	12,64		1,36
BSH02005_00	20		x								21,08	20h6	17,60	2,29	5 400	
BSH02005_01				x	x	x					21,08		17,60	2,29		
BSH02010_01					x	x							21,09	17,60		2,35
BSH02020_01					x	x							20,76	17,28		2,36
BSH02505_00	25		x								26,08	25h6	22,60	3,60	5 400	
BSH02505_01				x	x	x					26,08		22,60	3,60		
BSH02510_00			x								x		26,62	21,26		3,52
BSH02510_01				x	x	x							26,09	22,60		3,73
BSH02525_01					x	x							26,09	22,61		3,79
BSH03205_00	32		x								33,08	32h6	29,60	6,00	5 400	
BSH03205_01				x	x	x					33,08		29,60	6,00		
BSH03210_00			x								x		34,15	27,18		5,65
BSH03210_01					x	x	x						32,35	28,00		5,67
BSH03220_01					x	x	x						32,35	28,00		5,79
BSH03232_01					x	x							32,36	28,00		5,83
BSH04005_00	40		x								41,08	40h6	37,60	9,32	5 400	
BSH04005_01					x	x					41,08		37,60	9,32		
BSH04010_00			x								x		42,15	35,18		9,05
BSH04010_01					x	x							39,52	32,55		8,05
BSH04020_01						x	x						39,52	32,55		8,33
BSH04040_01							x						39,52	32,55		8,66
BSH05010_00	50		x								52,15	50h6	45,18	14,17	5 400	
BSH05005_01					x	x					51,08		47,61	14,91		
BSH05010_01					x	x							50,15	43,81		13,20
BSH05020_01					x	x							50,15	43,81		13,63
BSH05050_01						x							50,15	43,81		13,63
BSH06310_00	63		x								65,15	63h6	58,18	23,19	5 400	
BSH06320_00										x			66,25	55,98		22,72
BSH08010_00	80		x								82,15	80h6	75,18	37,33	5 400	
BSH08020_00										x			83,25	72,99		37,12

5.1.5 Preload classes

The preload classes possible for SNR Ball Screws depend on the nut type, pitch and manufacturing process of the shaft. Table 5.7 contains the possible preload classes for SNR Ball Screws.

Table 5.7 Preload classes for SNR Ball Screws

Preload class	Description	
	rolled Ball Screws	whirled Ball Screws
Z0	Axial clearance $\leq \varnothing 14: \leq 0,05 \text{ mm}$ $\leq \varnothing 40: \leq 0,08 \text{ mm}$ $> \varnothing 40: \leq 0,12 \text{ mm}$	Axial clearance $\leq 0,005 \text{ mm}$
Z1	without axial clearance	without axial clearance
Z2		Light preload ($\leq 3\% \text{ Ca}$)
Z3		Medium preload ($\leq 5\% \text{ Ca}$)
Z4		High preload ($\leq 7\% \text{ Ca}$)
ZX	Special preload according drawing	Special preload according drawing

5.1.5.1 Rolled Ball Screws

The possible standard preload classes for the different nut types of rolled Ball Screws are summarized in Table 5.8.

Table 5.8 Standard preload classes for rolled Ball Screws

Shaft type	Nut type					
	CI	CD	SC	SH	SK	SU
BSH00601 00 R					Z0	
BSH00801 00 R					Z0	
BSH00802 00 R					Z0	
BSH00802.5 00 R				Z0	Z0	
BSH01002 00 R				Z0	Z0	
BSH01004 00 R				Z0	Z0	
BSH01202 00 R					Z0	
BSH01204 00 R				Z0		
BSH01205 00 R	Z0			Z0		
BSH01205 01 R			Z0, Z1			
BSH01210 01 R			Z0, Z1			
BSH01402 00 R					Z0	
BSH01404 00 R					Z0	
BSH01604 00 R				Z0, Z1		
BSH01605 00 R	Z0, Z1			Z0, Z1		Z0, Z1
BSH01605 01 R		Z0, Z1	Z0, Z1			
BSH01610 00 R						Z0, Z1
BSH01610 01 R		Z0, Z1	Z0, Z1			
BSH01616 01 R		Z0, Z1	Z0, Z1			
BSH01620 01 R			Z0, Z1			
BSH02005 00 R	Z0, Z1			Z0, Z1		Z0, Z1
BSH02005 01 R		Z0, Z1	Z0, Z1			
BSH02010 01 R			Z0, Z1			
BSH02020 01 R		Z0, Z1	Z0, Z1			
BSH02505 00 R	Z0, Z1			Z0, Z1		Z0, Z1
BSH02005 01 R		Z0, Z1	Z0, Z1			
BSH02510 00 R	Z0, Z1					Z0, Z1
BSH02010 01 R			Z0, Z1			
BSH02020 01 R		Z0, Z1	Z0, Z1			
BSH03205 00 R	Z0, Z1					Z0, Z1
BSH03205 01 R		Z0, Z1	Z0, Z1			
BSH03210 00 R	Z0, Z1					Z0, Z1
BSH03210 01 R		Z0, Z1	Z0, Z1			
BSH03220 01 R		Z0, Z1	Z0, Z1			
BSH03232 01 R		Z0, Z1	Z0, Z1			
BSH04005 00 R	Z0, Z1					Z0, Z1
BSH04005 01 R			Z0, Z1			
BSH04010 00 R	Z0, Z1					Z0, Z1
BSH04010 01 R			Z0, Z1			
BSH04020 01 R			Z0, Z1			
BSH04040 01 R			Z0, Z1			
BSH05010 00 R	Z0, Z1					Z0, Z1
BSH05005 01 R			Z0, Z1			
BSH05010 01 R			Z0, Z1			
BSH05020 01 R			Z0, Z1			
BSH05050 01 R			Z0, Z1			
BSH06310 00 R	Z0, Z1					Z0, Z1
BSH06320 00 R						Z0, Z1
BSH08010 00 R	Z0, Z1					Z0, Z1
BSH08020 00 R						Z0, Z1

5.1.5.2 Whirled Ball Screws

The possible standard preload classes for the different nut types of whirled Ball Screws are summarized in Table 5.9.

Table 5.9 Standard preload classes for whirled Ball Screws

Shaft type	Nut type							
	CI	CD	DC	SC	SH	SK	SU	TW
BSH00801_00_W						Z0, Z1		
BSH00802_00_W						Z0, Z1		
BSH00802.5_00_W					Z0, Z1	Z0, Z1		
BSH01002_00_W					Z0, Z1	Z0, Z1		
BSH01004_00_W					Z0, Z1	Z0, Z1		
BSH01202_00_W						Z0, Z1		
BSH01204_00_W					Z0, Z1			
BSH01205_00_W	Z0, Z1				Z0, Z1			
BSH01205_01_W				Z0, Z1, Z2				
BSH01210_01_W				Z0, Z1				
BSH01402_00_W						Z0, Z1		
BSH01404_00_W					Z0, Z1			
BSH01604_00_W					Z0, Z1, Z2			
BSH01605_00_W	Z0, Z1, Z2				Z0, Z1, Z2		Z0, Z1, Z2	Z0, Z1, Z2
BSH01605_01_W		Z0, Z1, Z2	Z1, Z2, Z3, Z4	Z0, Z1, Z2				
BSH01610_00_W							Z0, Z1	
BSH01610_01_W		Z0, Z1, Z2	Z1, Z2, Z3, Z4	Z0, Z1				
BSH01616_01_W		Z0, Z1		Z0, Z1				
BSH01620_01_W				Z0, Z1				
BSH02005_00_W	Z0, Z1, Z2				Z0, Z1, Z2		Z0, Z1, Z2	Z0, Z1, Z2
BSH02005_01_W		Z0, Z1, Z2	Z1, Z2, Z3, Z4	Z0, Z1, Z2				
BSH02010_01_W			Z1, Z2, Z3, Z4	Z0, Z1				
BSH02020_01_W		Z0, Z1		Z0, Z1				
BSH02505_00_W	Z0, Z1, Z2				Z0, Z1, Z2		Z0, Z1, Z2	Z0, Z1, Z2
BSH02505_01_W		Z0, Z1, Z2	Z1, Z2, Z3, Z4	Z0, Z1, Z2				
BSH02510_00_W	Z0, Z1, Z2						Z0, Z1, Z2	Z0, Z1, Z2
BSH02510_01_W		Z0, Z1, Z2	Z1, Z2, Z3, Z4	Z0, Z1				
BSH02525_01_W		Z0, Z1		Z0, Z1				
BSH03205_00_W	Z0, Z1, Z2						Z0, Z1, Z2	Z0, Z1, Z2
BSH03205_01_W		Z0, Z1, Z2	Z1, Z2, Z3, Z4	Z0, Z1, Z2				
BSH03210_00_W	Z0, Z1, Z2						Z0, Z1, Z2	Z0, Z1, Z2
BSH03210_01_W		Z0, Z1, Z2	Z1, Z2, Z3, Z4	Z0, Z1, Z2				
BSH03220_01_W		Z0, Z1	Z1, Z2, Z3, Z4	Z0, Z1				
BSH03232_01_W		Z0, Z1		Z0, Z1				
BSH04005_00_W	Z0, Z1, Z2						Z0, Z1, Z2	Z0, Z1, Z2
BSH04005_01_W			Z1, Z2, Z3, Z4	Z0, Z1, Z2				
BSH04010_00_W	Z0, Z1, Z2						Z0, Z1, Z2	Z0, Z1, Z2
BSH04010_01_W			Z1, Z2, Z3, Z4	Z0, Z1, Z2				
BSH04020_01_W			Z1, Z2, Z3, Z4	Z0, Z1				
BSH04040_01_W				Z0, Z1				
BSH05010_00_W	Z0, Z1, Z2						Z0, Z1, Z2	Z0, Z1, Z2
BSH05005_01_W			Z1, Z2, Z3, Z4	Z0, Z1, Z2				
BSH05010_01_W			Z1, Z2, Z3, Z4	Z0, Z1, Z2				
BSH05020_01_W			Z1, Z2, Z3, Z4	Z0, Z1, Z2				
BSH05050_01_W				Z0, Z1				
BSH06310_00_W	Z0, Z1, Z2						Z0, Z1, Z2	Z0, Z1, Z2
BSH06320_00_W							Z0, Z1, Z2	
BSH08010_00_W	Z0, Z1, Z2						Z0, Z1, Z2	Z0, Z1, Z2
BSH08020_00_W							Z0, Z1, Z2	

5.1.6 Sealing options

The nuts of SNR Ball Screws can be equipped with different sealing options depending on their type and size. Table 5.10 contains an overview of the possible sealing options.

Table 5.10 ___ Sealing options of SNR Ball Screws

Nut type	Nominal diameter d_0 [mm]	Sealing options		
		without seals AA	Labyrinth seals LL	Lip seals UU
CD	$\emptyset 12$	S	-	-
	$> \emptyset 12$	-	-	S
CI	all	-	S	-
DC	all	-	S	-
SC	all	-	S	-
SH	$\leq \emptyset 16$	S	-	-
	$\geq \emptyset 20$	-	S	-
SK	all	S	-	-
SU	all	-	S	-
TW	all	-	S	-

S Standard
- not possible

5.1.7 Permissible DN values

The permissible DN values of nuts for SNR Ball Screws depending on the ball deflection system of the nut and the manufacturing process of the shaft. The permissible DN values are summarized in Table 5.11.

Table 5.11 ___ DN values of SNR Ball Screws

Nut type	DN value [mm min ⁻¹]		
	rolled	whirled	grinded
CD	70 000	80 000	80 000
CI	70 000	80 000	80 000
DC	80 000	100 000	100 000
SC	80 000	100 000	100 000
SH	70 000	80 000	80 000
SK	70 000	80 000	80 000
SU	70 000	80 000	80 000
TW	70 000	80 000	80 000

5.2 Nut types for SNR Ball Screws

5.2.1 Compact single nut according DIN 69051 type SC

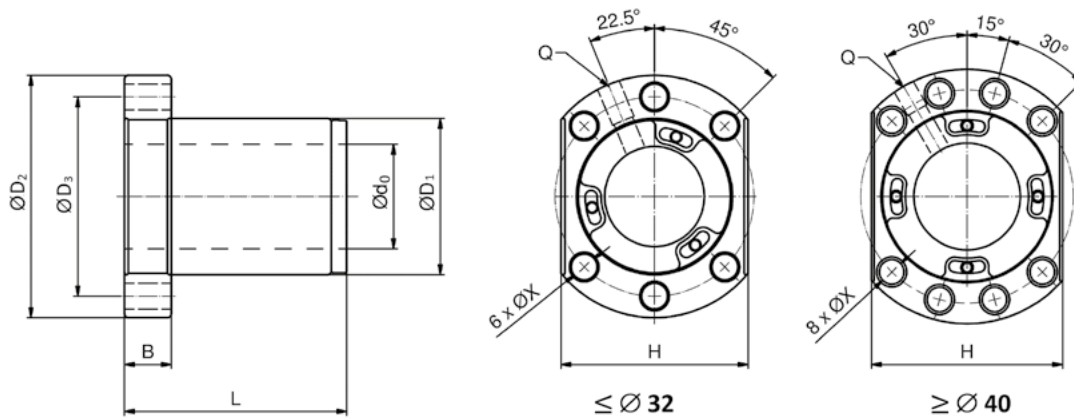
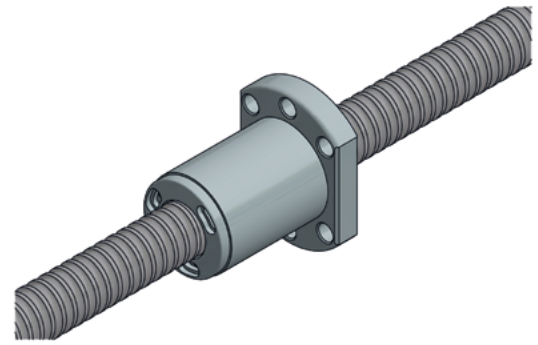

Type	Pitch direction	Dimension										Number of circuits	Load ratings		Rigidity K_N [N/ μ m]	
		d_0 [mm]	P [mm]	D_w [mm]	D_1 g6 [mm]	$D_2 \pm 0,15$ [mm]	$B \pm 0,10$ [mm]	$L \pm 0,15$ [mm]	$D_3 \pm 0,15$ [mm]	$H \pm 0,15$ [mm]	X [mm]		Q	C_a [kN]		C_{0a} [kN]
BNU01205_SC_2	right	12	5	2,500	24	40	10	30	32	30*	4,5	M 6	2,8 x 1	5,84	11,61	186
BNU01210_SC_2	right	12	10	2,500	24	40	10	45	32	30*	4,5	M 6	2,8 x 1	5,67	11,36	186
BNU01605_SC_3	right	16	5	2,778	28	48	10	37	38	40	5,5	M 6	3,8 x 1	9,82	22,12	294
BNU01610_SC_2	right	16	10	2,778	28	48	10	47	38	40	5,5	M 6	2,8 x 1	7,40	16,07	226
BNU01616_SC_1	right	16	16	2,778	28	48	10	45	38	40	5,5	M 6	1,8 x 1	4,87	10,03	137
BNU01616_SC_2	right	16	16	2,778	28	48	10	61	38	40	5,5	M 6	2,8 x 1	7,13	15,61	216
BNU01620_SC_1	right	16	20	2,778	28	48	10	57	38	40	5,5	M 6	1,8 x 1	4,89	10,33	137
BNU02005_SC_3	right	20	5	3,175	36	58	10	37	47	44	6,6	M 6	3,8 x 1	13,10	32,49	363
BNU02010_SC_3	right	20	10	3,175	36	58	10	57	47	44	6,6	M 6	3,8 x 1	13,38	33,83	392
BNU02020_SC_1	right	20	20	3,175	36	58	10	54	47	44	6,6	M 6	1,8 x 1	6,75	15,51	186
BNU02020_SC_2	right	20	20	3,175	36	58	10	74	47	44	6,6	M 6	2,8 x 1	9,87	24,13	284
BNU02505_SC_3	right	25	5	3,175	40	62	12	37	51	48	6,6	M 6	3,8 x 1	14,56	41,11	422
BNU02510_SC_3	right	25	10	3,175	40	62	12	57	51	48	6,6	M 6	3,8 x 1	14,46	40,89	441
BNU02525_SC_1	right	25	25	3,175	40	62	12	65	51	48	6,6	M 6	1,8 x 1	7,44	19,41	215
BNU02525_SC_2	right	25	25	3,175	40	62	12	90	51	48	6,6	M 6	2,8 x 1	10,88	30,20	333
BNU03205_SC_3	right	32	5	3,175	50	80	13	37	65	62	9,0	M 6	3,8 x 1	16,23	53,18	500
BNU03210_SC_3	right	32	10	3,969	50	80	13	60	65	62	9,0	M 6	3,8 x 1	21,71	64,04	539
BNU03220_SC_2	right	32	20	3,969	50	80	12	80	65	62	9,0	M 6	2,8 x 1	16,83	48,39	422
BNU03232_SC_1	right	32	32	3,969	50	80	13	82	65	62	9,0	M 6	1,8 x 1	11,09	30,23	265
BNU03232_SC_2	right	32	32	3,969	50	80	13	114	65	62	9,0	M 6	2,8 x 1	16,22	47,03	412
BNU04005_SC_3	right	40	5	3,175	63	93	14	37	78	70	9,0	M 8 x 1	3,8 x 1	17,81	66,98	588
BNU04010_SC_3	right	40	10	6,350	63	93	14	63	78	70	9,0	M 8 x 1	3,8 x 1	44,44	123,06	657
BNU04020_SC_2	right	40	20	6,350	63	93	14	86	78	70	9,0	M 8 x 1	2,8 x 1	34,94	94,58	533
BNU04040_SC_1	right	40	40	6,350	63	93	15	105	78	70	9,0	M 8 x 1	1,8 x 1	22,82	58,67	333
BNU04040_SC_2	right	40	40	6,350	63	93	15	145	78	70	9,0	M 8 x 1	2,8 x 1	33,36	91,27	510
BNU05005_SC_3	right	50	5	3,175	75	110	18	37	93	85	11,0	M 8 x 1	3,8 x 1	19,48	84,22	667
BNU05010_SC_3	right	50	10	6,350	75	110	18	68	93	85	11,0	M 8 x 1	3,8 x 1	49,76	157,56	775
BNU05020_SC_3	right	50	20	6,350	75	110	18	108	93	85	11,0	M 8 x 1	3,8 x 1	50,74	163,15	853
BNU05050_SC_1	right	50	50	6,350	75	110	18	125	93	85	11,0	M 8 x 1	1,8 x 1	26,00	77,22	412
BNU05050_SC_2	right	50	50	6,350	75	110	18	175	93	85	11,0	M 8 x 1	2,8 x 1	38,02	120,12	637

* Tolerance $\pm 0,10$

5.2.2 Compact double nut according DIN 69051 type DC

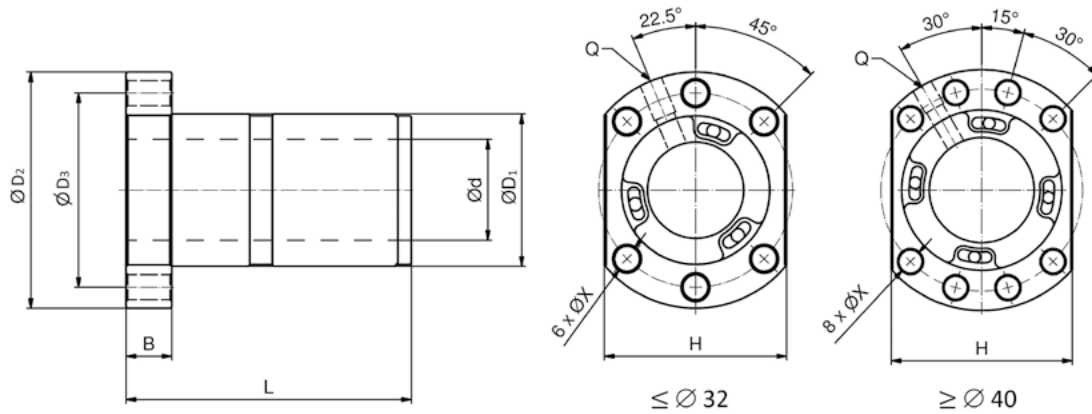
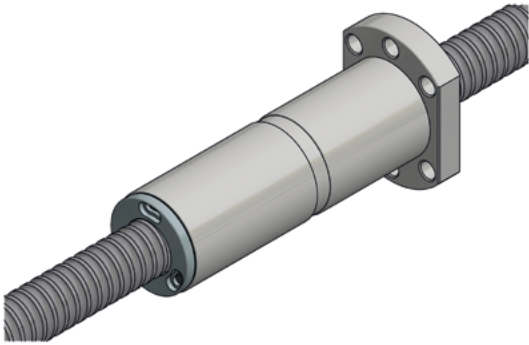

Type	Pitch direction	d_0 [mm]	P [mm]	D_w [mm]	D_1 g6 [mm]	$D_2 \pm 0,15$ [mm]	Dimension					Q	Number of circuits	Load ratings		Rigidity K_N [N/μm]
							$B \pm 0,10$ [mm]	$L \pm 0,15$ [mm]	$D_3 \pm 0,15$ [mm]	$H \pm 0,15$ [mm]	X [mm]			C_a [kN]	C_{0a} [kN]	
BNU01605_DC_3	right	16	5	2,778	28	48	10	72,0	38	40	5,5	M 6	3,8 x 1	9,82	22,12	402
BNU01610_DC_2	right	16	10	2,778	28	48	10	92,0	38	40	5,5	M 6	2,8 x 1	7,40	16,07	304
BNU02005_DC_3	right	20	5	3,175	36	58	10	72,0	47	44	6,6	M 6	3,8 x 1	13,10	32,49	490
BNU02010_DC_3	right	20	10	3,175	36	58	10	112,0	47	44	6,6	M 6	3,8 x 1	13,38	33,83	520
BNU02505_DC_3	right	25	5	3,175	40	62	10	72,0	51	48	6,6	M 6	3,8 x 1	14,56	41,11	579
BNU02510_DC_3	right	25	10	3,175	40	62	12	112,0	51	48	6,6	M 6	3,8 x 1	14,46	40,90	598
BNU03205_DC_3	right	32	5	3,175	50	80	12	72,0	65	62	9,0	M 6	3,8 x 1	16,23	53,18	696
BNU03210_DC_3	right	32	10	3,969	50	80	12	115,0	65	62	9,0	M 6	3,8 x 1	21,71	64,04	735
BNU03220_DC_2	right	32	20	3,969	50	80	12	160,0	65	62	9,0	M 6	2,8 x 1	16,83	48,39	569
BNU04005_DC_3	right	40	5	3,175	63	93	15	72,0	78	62	9,0	M 8 x 1	3,8 x 1	17,81	66,98	814
BNU04010_DC_3	right	40	10	6,350	63	93	14	122,5	78	70	9,0	M 8 x 1	3,8 x 1	44,44	123,06	892
BNU04020_DC_2	right	40	20	6,350	63	93	14	166,0	78	70	9,0	M 8 x 1	2,8 x 1	34,94	94,58	716
BNU05005_DC_3	right	50	5	3,175	75	110	15	73,0	93	85	11,0	M 8 x 1	3,8 x 1	19,48	84,22	941
BNU05010_DC_3	right	50	10	6,350	75	110	18	138,0	93	85	11,0	M 8 x 1	3,8 x 1	49,76	157,56	1 069
BNU05020_DC_3	right	50	20	6,350	75	110	18	207,5	93	85	11,0	M 8 x 1	3,8 x 1	50,74	163,15	1 138

5.2.3 Standard single nut according DIN 69051 type SU

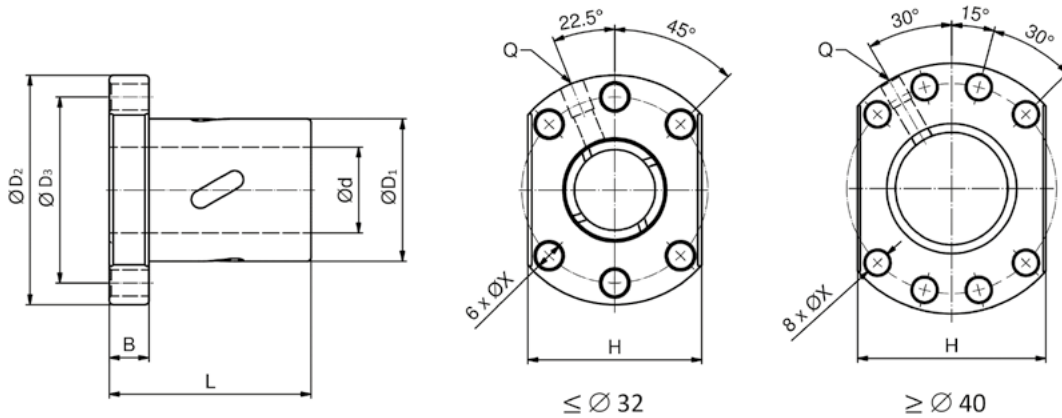
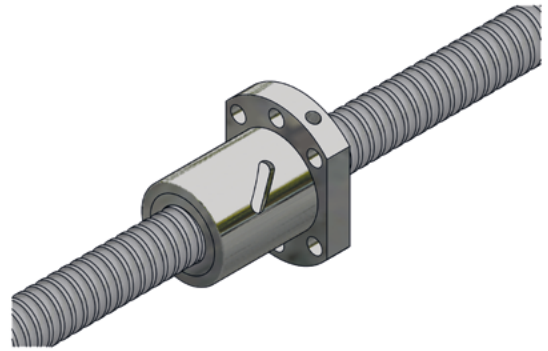

Type	Pitch direction	d_0 [mm]	P [mm]	D_w [mm]	D_1 g6 [mm]	$D_2 \pm 0,15$ [mm]	Dimension					X [mm]	Q	Number of circuits	Load ratings		Rigidity K_N [N/ μ m]
							$B \pm 0,10$ [mm]	$L \pm 0,15$ [mm]	$D_3 \pm 0,15$ [mm]	$H \pm 0,15$ [mm]	C_a [kN]				C_{0a} [kN]		
BNU01605_SU_4	right / left	16	5	3,175	28	48	10	50	38	40	5,5	M 6	1 x 4	12,18	26,94	314	
BNU01610_SU_3	right / left	16	10	3,175	28	48	10	57	38	40	5,5	M 6	1 x 3	9,74	21,19	255	
BNU02005_SU_4	right / left	20	5	3,175	36	58	10	51	47	44	6,6	M 6	1 x 4	13,69	34,21	382	
BNU02505_SU_4	right / left	25	5	3,175	40	62	10	51	51	48	6,6	M 6	1 x 4	15,22	43,29	441	
BNU02510_SU_4	right / left	25	10	4,762	40	62	12	85	51	48	6,6	M 6	1 x 4	26,08	64,39	490	
BNU03205_SU_4	right / left	32	5	3,175	50	80	12	52	65	62	9,0	M 6	1 x 4	16,97	55,99	530	
BNU03210_SU_4	right / left	32	10	6,350	50	80	12	90	65	62	9,0	M 6	1 x 4	42,41	107,75	598	
BNU04005_SU_4	right / left	40	5	3,175	63	93	14	55	78	70	9,0	M 8 x 1	1 x 4	18,62	70,50	618	
BNU04010_SU_4	right / left	40	10	6,350	63	93	14	93	78	70	9,0	M 8 x 1	1 x 4	47,65	136,80	716	
BNU05010_SU_4	right / left	50	10	6,350	75	110	16	93	93	85	11,0	M 8 x 1	1 x 4	53,00	173,12	834	
BNU06310_SU_4	right	63	10	6,350	90	125*	18	98	108	95	11,0	M 8 x 1	1 x 4	59,30	223,81	970	
BNU06320_SU_4	right	63	20	9,525	95	135*	20	149	115	100	13,5	M 8 x 1	1 x 4	101,00	323,50	1 069	
BNU08010_SU_4	right	80	10	6,350	105	145*	20	98	125*	110	13,5	M 8 x 1	1 x 4	64,83	282,02	1 069	
BNU08020_SU_4	right	80	20	9,525	125	165	25	154	145	130	13,5	M 8 x 1	1 x 4	113,95	421,41	1 354	

* Tolerance $\pm 0,10$

5.2.4 Standard single nut with pitch offset according DIN 69051 type TW

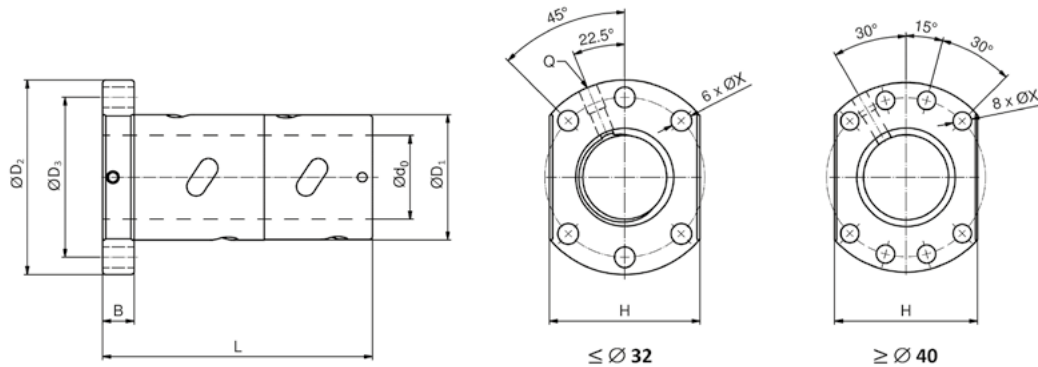
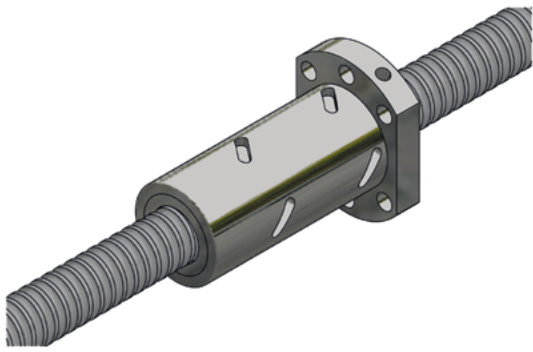

Type	Pitch direction	Dimension										Number of circuits	Load ratings		Rigidity K_N [N/μm]	
		d_0 [mm]	P [mm]	D_w [mm]	D_1 g6 [mm]	$D_2 \pm 0,15$ [mm]	$B \pm 0,10$ [mm]	$L \pm 0,15$ [mm]	$D_3 \pm 0,15$ [mm]	$H \pm 0,15$ [mm]	X [mm]		Q	C_a [kN]		C_{0a} [kN]
BNU01605_TW_4	right	16	5	3,175	28	48	10	75	38	40	5,5	M 6	1 x 4	12,18	26,94	431
BNU02005_TW_4	right	20	5	3,175	36	58	10	85	47	44	6,6	M 6	1 x 4	13,69	34,21	519
BNU02505_TW_4	right	25	5	3,175	40	62	10	86	51	48	6,6	M 6	1 x 4	15,22	43,29	608
BNU02510_TW_4	right	25	10	4,762	40	62	12	130	51	48	6,6	M 6	1 x 4	26,08	64,39	657
BNU03205_TW_4	right	32	5	3,175	50	80	12	87	65	62	9,0	M 6	1 x 4	16,97	55,99	726
BNU03210_TW_4	right	32	10	6,350	50	80	12	145	65	62	9,0	M 6	1 x 4	42,41	107,75	804
BNU04005_TW_4	right	40	5	3,175	63	93	14	90	78	70	9,0	M 8 x 1	1 x 4	18,62	70,50	853
BNU04010_TW_4	right	40	10	6,350	63	93	14	148	78	70	9,0	M 8 x 1	1 x 4	47,65	136,80	971
BNU05010_TW_4	right	50	10	6,350	75	110	16	148	93	85	11,0	M 8 x 1	1 x 4	53,00	173,12	1 147
BNU06310_TW_4	right	63	10	6,350	90	125*	18	153	108	95	11,0	M 8 x 1	1 x 4	59,30	223,81	1 363
BNU08010_TW_4	right	80	10	6,350	105	145*	20	153	125*	110	13,5	M 8 x 1	1 x 4	64,83	282,02	1 530

* Tolerance $\pm 0,20$

5.2.5 Cylindrical single nut type CI

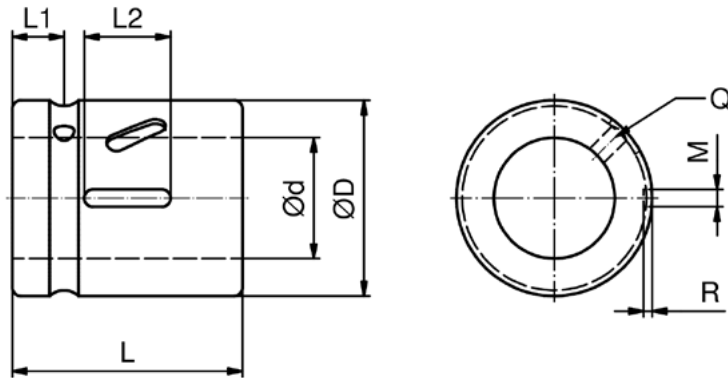
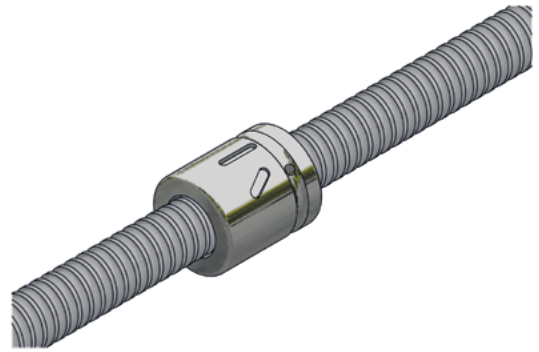

Type	Pitch direction	Dimension										Number of circuits	Load ratings		Rigidity K_N [N/µm]
		d_0 [mm]	P [mm]	D_w [mm]	D_1 , g6 [mm]	L [mm]	L1 [mm]	Q [mm]	L2 [mm]	M P9 [mm]	R [mm]		C_a [kN]	C_{0a} [kN]	
BNU01205_CI_3	right	12	5	2,500	21	33	3,5	2	12	3	1,8	2,8 x 1	6,89	13,82	139
BNU01605_CI_4	right / left	16	5	3,175	28	45	9	3,5	20	5	3,0	1 x 4	12,18	26,94	314
BNU02005_CI_4	right / left	20	5	3,175	36	45	9	3,5	20	5	3,0	1 x 4	13,69	34,21	382
BNU02505_CI_4	right / left	25	5	3,175	40	45	9	3,5	20	5	3,0	1 x 4	15,22	43,29	441
BNU02510_CI_4	right	25	10	4,762	40	85	13	3,5	30	5	3,0	1 x 4	26,08	64,39	490
BNU03205_CI_4	right / left	32	5	3,175	50	45	9	3,5	20	5	3,0	1 x 4	16,97	55,99	530
BNU03210_CI_4	right / left	32	10	6,350	50	85	13	3,5	30	5	3,0	1 x 4	42,41	107,75	598
BNU04005_CI_4	right / left	40	5	3,175	63	45	9	3,5	20	5	3,0	1 x 4	18,62	70,50	618
BNU04010_CI_4	right / left	40	10	6,350	63	85	13	3,5	30	5	3,0	1 x 4	47,65	136,80	716
BNU05010_CI_4	right / left	50	10	6,350	75	85	13	3,5	30	5	3,0	1 x 4	53,00	173,12	834
BNU06310_CI_4	right	63	10	6,350	90	85	13	3,5	30	6	3,5	1 x 4	59,30	223,81	970
BNU08010_CI_4	right	80	10	6,350	105	85	13	3,5	30	8	4,5	1 x 4	64,83	282,02	1 069

5.2.6 Compact cylindrical single nut type CD

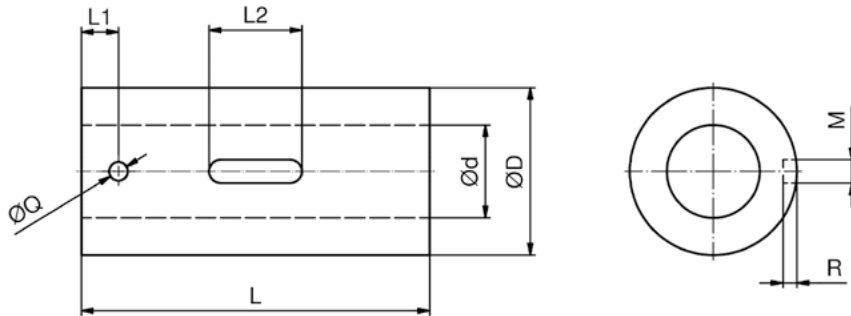
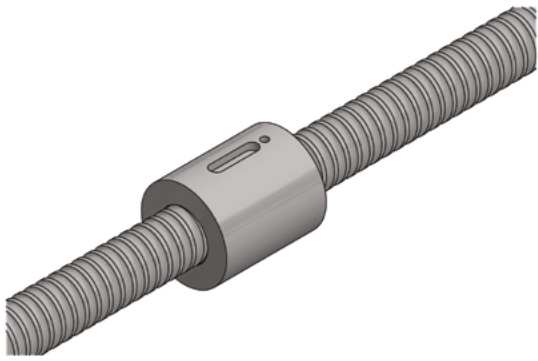

Type	Pitch direction	d ₀ [mm]	P [mm]	D _w [mm]	D ₁ g6 [mm]	Dimension						Number of circuits	Load ratings		Rigidity K _N [N/μm]
						L ±0,10 [mm]	L ₁ [mm]	Q [mm]	L ₂ [mm]	M P9 [mm]	R [mm]		C _a [kN]	C _{0a} [kN]	
BNU01605_CD_5	right	16	5	2,778	28	45	7,0	3	12	5	3,0	5,8 x 1	16,11	31,06	480
BNU01610_CD_2	right	16	10	2,778	28	45	9,5	3	16	5	3,0	2,8 x 1	8,24	17,83	226
BNU01616_CD_1	right	16	16	2,778	28	45	9,5	3	16	5	3,0	1,8 x 1	5,42	11,15	137
BNU02005_CD_4	right	20	5	3,175	36	42	8,0	3	16	5	3,0	4,8 x 1	17,79	45,61	343
BNU02020_CD_2	right	20	20	3,175	36	75	8,0	4	20	5	3,0	2,8 x 1	10,97	26,75	284
BNU02505_CD_4	right	25	5	3,175	40	45	8,5	3	16	5	3,0	4,8 x 1	19,78	57,70	431
BNU02510_CD_3	right	25	10	3,175	40	55	9,5	4	20	5	3,0	3,8 x 1	16,06	45,43	441
BNU02525_CD_2	right	25	25	3,175	40	89	18,0	4	20	5	3,0	2,8 x 1	12,08	33,56	333
BNU03205_CD_5	right	32	5	3,175	50	48	7,5	3	20	5	3,0	5,8 x 1	25,96	90,23	480
BNU03210_CD_5	right	32	10	3,969	50	77	9,5	3	20	5	3,0	5,8 x 1	29,51	89,91	421
BNU03220_CD_2	right	32	20	3,969	50	77	9,5	3	20	5	3,0	2,8 x 1	18,71	53,78	265
BNU03232_CD_2	right	32	32	3,969	50	112	9,5	3	20	5	3,0	2,8 x 1	18,83	52,28	412

5.2.7 Cylindrical screw-in nut type SH

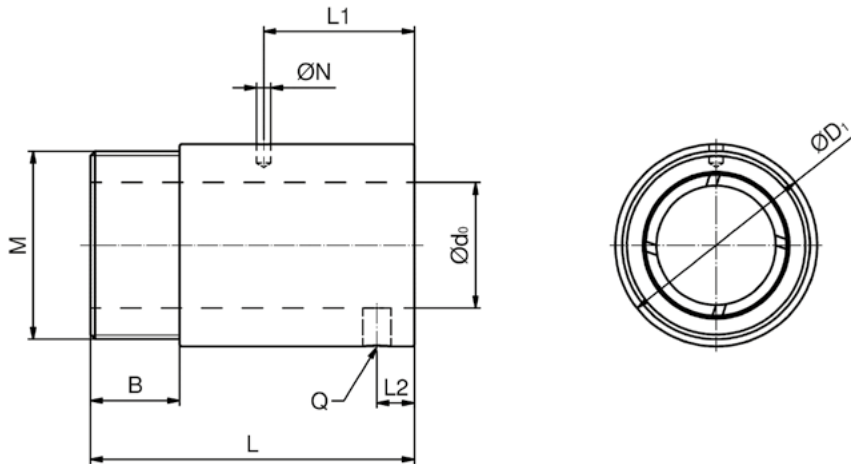
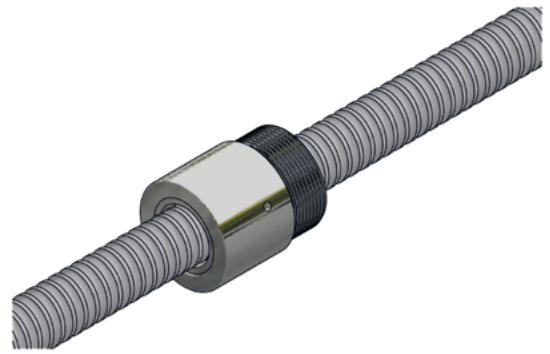

Type	Pitch direction	d ₀ [mm]	P [mm]	D _w [mm]	D ₁ [mm]	M [mm]	Dimension						Number of circuits	Load ratings		Rigidity K _N [N/μm]
							B [mm]	L ±0,15 [mm]	L1 [mm]	N [mm]	L2 [mm]	Q		C _a [kN]	C _{0a} [kN]	
BNU00802.5_SH_2	right	8	2,5	1,200	17,5	M15x1	7,5	23,5	10,00	3,0	-	-	2,5 x 1	1,67	3,36	108
BNU01002_SH_3	right	10	2	1,200	19,5	M17x1	7,5	22,0	3,00	3,2	-	-	3,5 x 1	2,44	5,86	167
BNU01004_SH_2	right	10	4	2,000	25,0	M20x1	10,0	34,0	3,00	3,0	-	-	2,5 x 1	3,53	6,66	137
BNU01204_SH_3	right	12	4	2,500	25,5	M20x1	10,0	34,0	13,00	3,0	4	M6	3,5 x 1	7,10	14,55	226
BNU01205_SH_3	right	12	5	2,500	25,5	M20x1	10,0	39,0	16,25	3,0	-	-	3,5 x 1	7,07	14,51	235
BNU01404_SH_3	right	14	4	2,381	32,1	M25x1,5	10,0	35,0	13,00	3,0	4	M6	3,5 x 1	6,60	14,20	255
BNU01604_SH_3	right	16	4	2,381	29,0	M22x1,5	8,0	32,0	4,00	3,2	4	M6	3 x 1	6,61	15,91	235
BNU01605_SH_3	right	16	5	3,175	32,5	M26x1,5	12,0	42,0	19,25	3,0	4	M6	3 x 1	9,50	20,20	245
BNU02005_SH_3	right	20	5	3,175	38,0	M35x1,5	15,0	45,0	20,30	3,0	4	M6	3 x 1	10,69	25,64	294
BNU02505_SH_4	right	25	5	3,175	43,0	M40x1,5	19,0	69,0	32,11	3,0	8	M6	4 x 1	15,22	43,29	363

5.2.8 Miniature single nut type SK

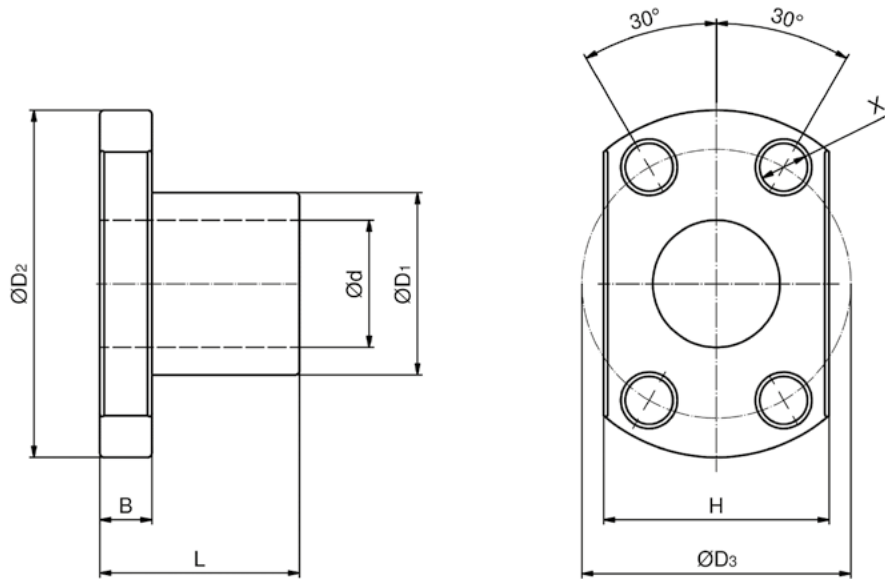
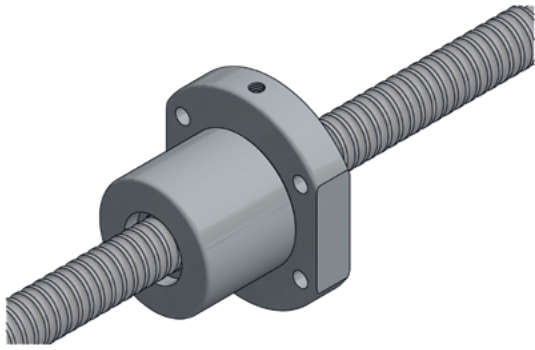

Type	Pitch direction	d [mm]	P [mm]	D_w [mm]	D_1 g6 [mm]	Dimension						Number of circuits	Load ratings		Rigidity K_N [N/ μ m]
						D_2 [mm]	B [mm]	L [mm]	D_3 [mm]	$H \pm 0,10$ [mm]	X [mm]		C_a [kN]	C_{0a} [kN]	
BNU00601_SK_3	right	6	1	0,800	12	24	3,5	15	18	16	3,4	1 x 3	0,97	1,97	88
BNU00801_SK_4	right	8	1	0,800	14	27	4,0	16	21	18	3,4	1 x 4	1,42	3,56	137
BNU00802_SK_3	right	8	2	1,200	14	27	4,0	16	21	18	3,4	1 x 3	1,96	4,04	127
BNU00802.5_SK_3	right	8	2,5	1,200	16	29	4,0	26	23	20	3,4	1 x 3	1,95	4,03	127
BNU01002_SK_3	right	10	2	1,200	18	35	5,0	28	27	22	4,5	1 x 3	2,15	5,02	147
BNU01004_SK_3	right	10	4	2,000	26	46	10,0	34	36	28	4,5	1 x 3	4,13	7,99	167
BNU01202_SK_4	right	12	2	1,200	20	37	5,0	28	29	24	4,5	1 x 4	2,95	7,99	216
BNU01204_SK_3	right	12	4	2,500	24	40	6,0	33	32	25	3,5	1 x 3	6,21	12,46	255
BNU01205_SK_3	right	12	5	2,500	22	37	8,0	39	29	24	4,5	1 x 3	6,19	12,43	186
BNU01402_SK_4	right	14	2	1,200	21	40	6,0	23	31	26	5,5	1 x 4	3,13	9,30	235

6. Accessories

6.1 Bearing units

6.1.1 Bearing units for Ball Screws with high loads

6.1.1.1 Fixed bearings for Ball Screws type BST

The NTN bearings for ball screws of the BST series are axial angular contact ball bearings with a 60 ° contact angle. The bearings are equipped with a rolling element guided polyamide cage and are characterized by improved rigidity, which is achieved due to a higher number of balls. The bearings are supplied in a universal design as standard and can be installed in any DB, DBT, DTBT and DBTT arrangement (Figure 6.1). The specially ground side surfaces give the bearings the required preload when installed.

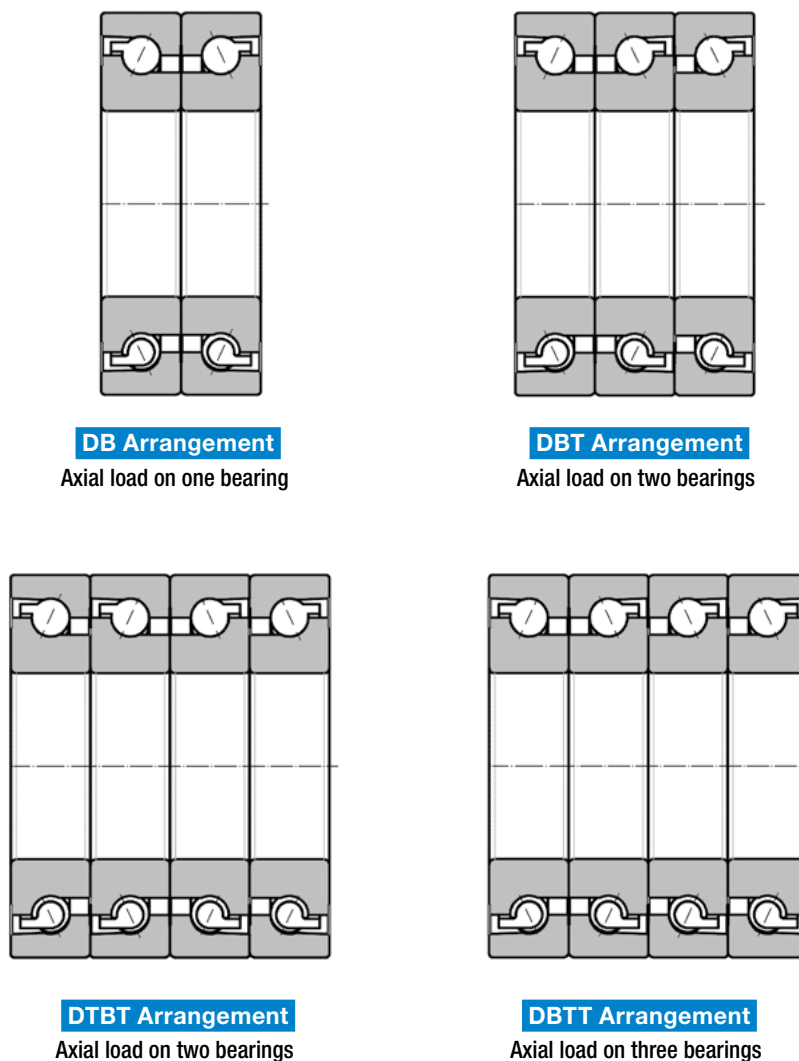

Figure 6.1 ___ Bearing arrangement NTN Angular contact ball bearings BST

Bearings of the BST series can be produced with light-contact seals (LXL) and without seals. For industrial applications, the version with seals is recommended. The bearings with seals are already filled with a special grease (L588) on delivery. The instructions in Chapter 3.3.2.1 must be observed for installation.

The type code has the following structure:

BST 20 x 47 - 1B LXL DBT P4 / L588

1 2 3 4 5 6 7 8

1	BST	Product BST: NTN angular contact ball bearings with 60° contact angle
2	20	Bore diameter [mm]
3	47	Outer diameter [mm]
4	1B	Preload code 1B: Standard preload 11B: Light preload
5	LXL	Sealing options without: without seals LXL: Light contact rubber seal
6	DBT	Bearing arrangement see Figure 6.1
7	P4	Precision class P5: ISO class 5 P4: ISO class 4 (Standard precision for Ball Screw bearings) UP: NTN standard
8	L588	Grease code without: without grease L588: Standard grease with Urea based special grease

The dimensions and load ratings of the BST series axial angular contact ball bearings suitable for SNR Ball Screws are summarized in Figure 6.2, Table 6.1 and Table 6.2.

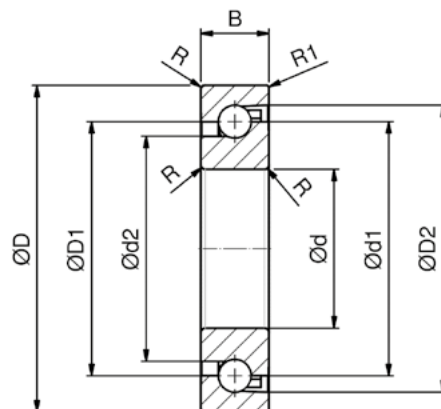

Figure 6.2___ NTN Angular contact ball bearings BST

Table 6.1 ____ Dimension NTN Angular contact ball bearings BST

Type Single bearing	ID Number	d ₀ [mm]	Shaft P [mm]	d	D	B	r _{min}	r _{1min}	d ₁	d ₂	D ₁	D ₂	Space capacity	Mass
				[mm]	[mm]	[mm]	[mm]	[mm]	[mm]	[mm]	[mm]	[mm]	[mm]	[mm]
BST17x47-1B P4	365081	25	all	17	47	15	1	0,6	29,9	27,1	37,1	40,8	3,3	0,132
BST17x47-1B LXL P4/L588	466253									25,7		41,2		
BST20x47-1B P4	221021	32	10	20	47	15	1	0,6	29,9	27,1	37,1	40,8	3,3	0,122
BST20x47-1B LXL P4/L588	466254									25,7		41,2		
BST25x62-1B P4	221025	32	4 / 5 / 20 / 32	25	62	15	1	0,6	44,4	41,6	51,6	55,3	4,6	0,235
BST25x62-1B LXL P4/L588	466255									40,2		55,7		
BST30x62-1B P4	198974	40	all	30	62	15	1	0,6	44,4	41,6	51,6	55,3	4,6	0,208
BST30x62-1B LXL P4/L588	466257									40,2		55,7		
BST35x72-1B P4	221032	50	10 / 20	35	72	15	1	0,6	52,4	49,6	59,6	63,2	5,4	0,306
BST35x72-1B LXL P4/L588	466258									48,2		63,7		
BST40x90-1B P4	221037	50	5 / 50	40	90	20	1	0,6	64,8	60,7	75,2	80,4	12,0	0,631
BST40x90-1B LXL P4/L588	466260									59,1		81,6		
BST50x100-1B P4	198980	63 / 80	all	50	100	20	1	0,6	75,8	71,7	86,2	91,4	13,0	0,727
BST50x100-1B LXL P4/L588	466261									70,1		92,6		

Table 6.2 ____ Load ratings NTN Angular contact ball bearings BST

Type Single bearing	Basic dynamic load rating C _a			Basic static load rating C _{0a}			Static axial load capacity		
	Number of bearings with axial load			Number of bearings with axial load			Number of bearings with axial load		
	1 [kN]	2 [kN]	3 [kN]	1 [kN]	2 [kN]	3 [kN]	1 [kN]	2 [kN]	3 [kN]
BST17x47-1B	24,3	39,5	52,5	37,5	75,0	113,0	25,7	51,5	77,0
BST17x47-1B LXL P4/L588									
BST20x47-1B	24,3	39,5	52,5	37,5	75,0	113,0	25,7	51,5	77,0
BST20x47-1B LXL P4/L588									
BST25x62-1B	29,2	47,5	63,0	59,0	118,0	177,0	40,0	80,5	121,0
BST25x62-1B LXL P4/L588									
BST30x62-1B	29,2	47,5	63,0	59,0	118,0	177,0	40,0	80,5	121,0
BST30x62-1B LXL P4/L588									
BST35x72-1B	31,0	50,5	67,0	70,0	140,0	210,0	47,5	95,0	143,0
BST35x72-1B LXL P4/L588									
BST40x90-1B	58,5	95,0	126,0	130,0	261,0	390,0	88,5	177,0	265,0
BST40x90-1B LXL P4/L588									
BST50x100-1B	62,0	101,0	134,0	153,0	305,0	459,0	104,0	208,0	315,0
BST50x100-1B LXL P4/L588									

Further dimensions and information on the NTN axial angular contact ball bearings of the BST series can be found in the NTN catalog "Precision Rolling Bearings", Chapter "Ball Screw Support Bearings".

Bearings for ball screw drives can be exposed to axial and radial loads.

To calculate the static safety and the nominal service lifetime, it is necessary to determine the static and dynamic equivalent load.

The static equivalent load is calculated according to Formula [6.1]. It must be ensured that the equivalent static load is smaller than the maximum static axial load.

$$P_{0a} = F_a + 3,98F_r$$

[Formula 6.1]

- P_{0a} Equivalent static load [kN]
- F_a Maximum axial load [kN]
- F_r Maximum radial load [kN]

The dynamic equivalent load is calculated according to Formula [6.2]. The correction factors X and Y are based on the ratio of axial load to radial load and the arrangement of the bearings. The correction factors can be found in Table 6.3.

$$P_a = XF_r + YF_a$$

[Formula 6.2]

- P_a Equivalent dynamic load [kN]
- F_a Maximum axial load [kN]
- F_r Maximum radial load [kN]
- X Correction factor
- Y Correction factor

Table 6.3____ Correction factors for the calculation of the dynamic equivalent load

Number of bearings in the arrangement		2		3		4		
Number of bearings with axial load				1	2	1	2	3
$F_a / F_r \leq 2,17$	X	1,90	1,43	2,32	1,17	1,90	2,52	
	Y	0,55	0,76	0,35	0,88	0,55	0,26	
$F_a / F_r > 2,17$	X	0,92	0,92	0,92	0,92	0,92	0,92	
	Y	1,00	1,00	1,00	1,00	1,00	1,00	

For the calculation of ball screws, the rigidity and starting torque of the bearings must be considered. Depending on the bearing arrangement and the sealing, these values are summarized in Table 6.4.

Table 6.4____ Starting torque and rigidity of NTN Angular contact ball bearings BST

Type	Bearing arrangement											
	Starting torque [Nm]	DB Preload 1B*		Starting torque [Nm]	DBT Preload 1B*		Starting torque [Nm]	DTBT Preload 1B*		Starting torque [Nm]	DBTT Preload 1B*	
		Preload force [kN]	axial spring constant [N/μm]		Preload force [kN]	axial spring constant [N/μm]		Preload force [kN]	axial spring constant [N/μm]		Preload force [kN]	axial spring constant [N/μm]
BST17x47-1B	0,175	2,06	635	0,245	2,84	930	0,355	4,10	1 270	0,275	3,23	1 140
BST17x47-1B LXL P4/L588	0,215			0,295			0,420			0,355		
BST20x47-1B	0,175	2,06	635	0,245	2,84	930	0,355	4,10	1 270	0,275	3,23	1 140
BST20x47-1B LXL P4/L588	0,215			0,295			0,420			0,355		
BST25x62-1B	0,305	3,25	980	0,420	4,40	1 370	0,615	6,45	1 960	0,470	5,10	1 740
BST25x62-1B LXL P4/L588	0,365			0,510			0,745			0,570		
BST30x62-1B	0,305	3,25	980	0,420	4,40	1 370	0,615	6,45	1 960	0,470	5,10	1 740
BST30x62-1B LXL P4/L588	0,365			0,510			0,745			0,570		
BST35x72-1B	0,380	3,80	1 130	0,510	5,20	1 620	0,755	7,65	2 260	0,590	5,96	2 030
BST35x72-1B LXL P4/L588	0,460			0,610			0,900			0,705		
BST40x90-1B	0,960	7,05	1 470	1,305	9,60	2 110	1,930	14,10	2 940	1,500	11,07	2 635
BST40x90-1B LXL P4/L588	1,155			1,570			2,315			1,805		
BST50x100-1B	1,165	8,25	1 720	1,580	11,20	2 450	2,340	16,50	3 450	1,815	12,95	3 050
BST50x100-1B LXL P4/L588	1,400			1,890			2,815			2,175		

* An Information on light preload 11B, s. NTN - Catalogue "Precision Rolling Bearings", Chapter "Ball Screw Support Bearings"

Information on the various versions of the standard end machining can be found in Chapter 6.2.1.1.

6.1.1.2 Fixed bearing unit for Ball Screws in block design type BSTK

The fixed bearing units for ball screws of the BSTK series are block type bearing units for high loads, especially in vertical applications. The bearing units are equipped with NTN axial angular contact ball bearings with a 60 ° contact angle from the BST series (Chapter 6.1.1.1). Depending on the size, the bearing units BSTK can contain bearings in a DB, DBT, DTBT and DBTT arrangement (Figure 6.3). The specially ground side surfaces give the bearings the required preload when installed.

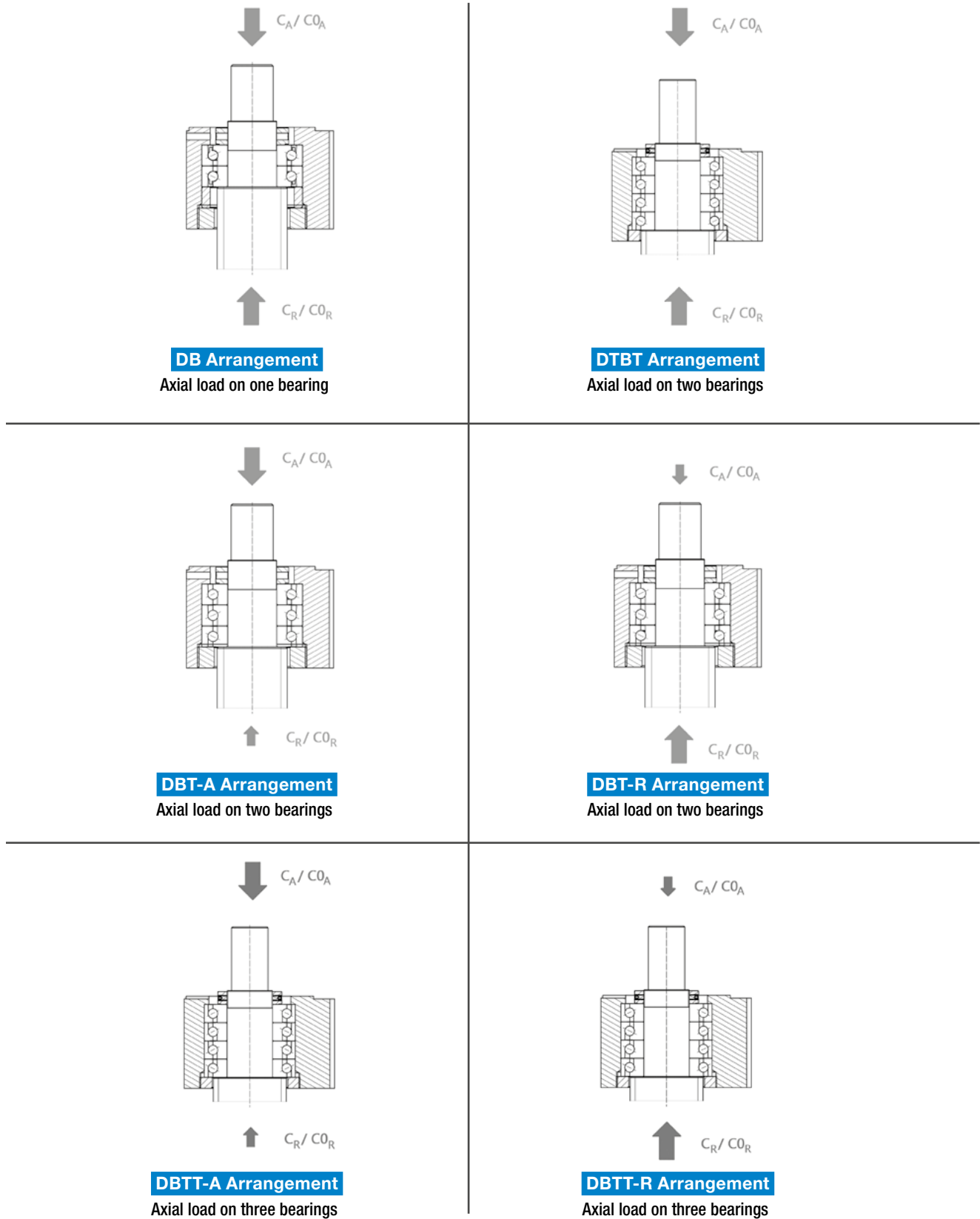

Figure 6.3 ___ Bearing arrangement in fixed bearing units BSTK

The bearings of the fixed bearing units of the BSTK series are equipped with light-contact seals (LXL) as standard and filled with a special grease (L588).

The instructions in Chapter 3.3.2.2 must be observed for assembly.

The type code has the following structure:

BSTK 20 - DBT - A

1 2 3 4

1	BSTK	Product BSTK: SNR Fixed bearing unit for Ball Screws
2	20	Bore diameter [mm]
3	DBT	Bearing arrangement see Figure 6.3
4	A	Bearing installation direction (only for Bearing arrangement DBT and DBTT) A: for tensile load R: for pressure load

The dimensions and load ratings of the for suitable for SNR ball screws bearing units BSTK are summarized in Figure 6.4, Table 6.5 and Table 6.6.

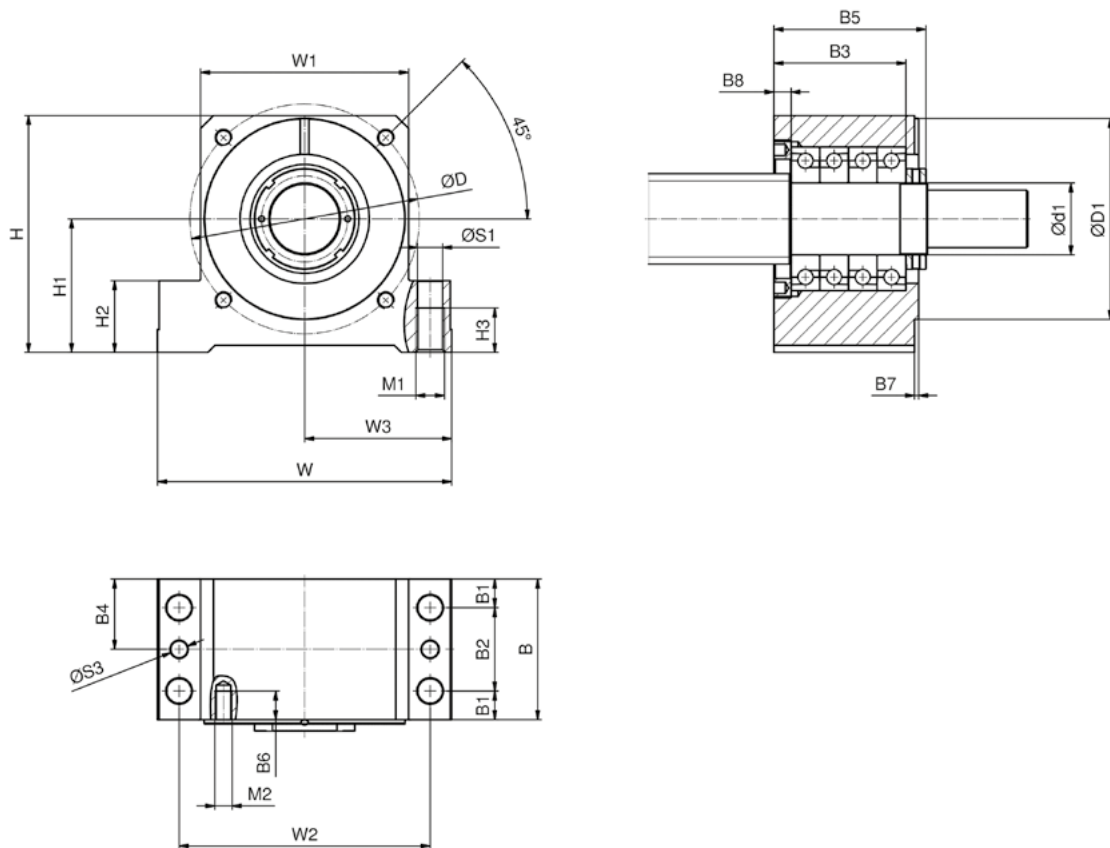

Figure 6.4 SNR Fixed bearing unit BSTK

Table 6.5 Dimension SNR Fixed bearing unit BSTK

Type	ID Number	d ₀ [mm]	P [mm]	d ₁ [mm]	H [mm]	H ₁ ±0,02 [mm]	H ₂ [mm]	H ₃ [mm]	W [mm]	W ₃ [mm]	W ₁ [mm]	W ₂ [mm]	B [mm]	B ₁ [mm]	B ₂ [mm]	B ₃ [mm]	B ₄ [mm]	B ₅ [mm]	B ₇ [mm]	B ₈ [mm]	H ₄ [mm]	S ₁ [mm]	S ₃ [mm]	M ₁ [mm]	D ₁ g6 [mm]	B ₅ [mm]	M ₂ [mm]	D [mm]	B ₆ [mm]	α °	Mass [g]	
BSTK17-DB	478433	25	5/10/25	17	72	39	27	18	108	54,0	66	88	46	8,5	29	38,0	23,0	48,0	2,0	8,0	10	10,2	9,7	M12	55	2,0	M6	70	12	45	1,8	
BSTK20-DB	478434	32	10	20	77	42	27	18	112	56,0	70	92	49	10,0	29	38,0	24,5	48,0	2,0	8,0	10	10,2	9,7	M12	65	2,0	M6	75	12	45	2,1	
BSTK25-DB	478435	32	4/5/20/32	25	77	42	27	18	112	56,0	71	92	49	10,0	29	39,0	24,5	51,0	2,0	9,0	10	10,2	9,7	M12	65	2,0	M8	75	20	45	1,9	
BSTK30-DB	478436	40	5/10/25	30	91	50	32	21	126	63,0	82	105	53	10,5	32	42,0	26,5	54,0	2,5	12,0	12	11,0	9,7	M14	80	2,5	M10	95	20	45	2,9	
BSTK30-DTBT	478437							24					83											12,5							58	72,0
BSTK35-DB	478439	50	10/20	35	105	58	38	24	144	72,0	92	118	70	13,5	43	60,0	35,0	72,5	2,5	15,0	12	13,0	9,7	M16	90	2,5	M10	110	17	45	5,0	
BSTK35-DBT-A	478440																														15,0	5,2
BSTK35-DBT-R	478441																														15,0	5,2
BSTK40-DB	478442	50	50	40	138	73	50	25	190	95,0	130	160	85	13,5	58	76,0	42,5	90,0	3,0	16,0	16	13,0	9,7	M16	110	3,0	M10	130	17	45	11,6	
BSTK40-DBT-A	478443																														16,0	11,9
BSTK40-DBT-R	478445																														16,0	11,9
BSTK50-DTBT	478446																														16,0	11,9
BSTK50-DBTT-A	478447	63/80	10/20	50	165	93	50	31	205	102,5	145	175	98	20,0	58	92,0	49,0	106,0	3,0	12,0	16	17,5	11,7	M20	140	3,0	M12	160	20	45	17,4	
BSTK50-DBTT-R	478448																															

Table 6.6 Load ratings SNR Fixed bearing unit BSTK

Type	Basic dynamic load rating		Basic static load rating		Static axial load capacity	
	Tensile direction C _A [kN]	Pressure direction C _R [kN]	Tensile direction C _{0A} [kN]	Pressure direction C _{0R} [kN]	Tensile direction [kN]	Pressure direction [kN]
BSTK17-DB	24,3	24,3	37,5	37,5	25,7	25,7
BSTK20-DB	24,3	24,3	37,5	37,5	25,7	25,7
BSTK25-DB	29,2	29,2	59,0	59,0	40,0	40,0
BSTK30-DB	29,2	29,2	59,0	59,0	40,0	40,0
BSTK30-DTBT	47,5	47,5	118,0	118,0	80,5	80,5
BSTK35-DB	31,0	31,0	118,0	118,0	47,5	47,5
BSTK35-DBT-A	50,5	31,0	140,0	118,0	95,0	47,5
BSTK35-DBT-R	31,0	50,5	118,0	140,0	47,5	95,0
BSTK40-DB	58,5	58,5	130,0	130,0	88,5	88,5
BSTK40-DBT-A	95,0	58,5	261,0	130,0	177,0	88,5
BSTK40-DBT-R	58,5	95,0	130,0	261,0	88,5	177,0
BSTK50-DTBT	101,0	101,0	305,0	305,0	208,0	208,0
BSTK50-DBTT-A	134,0	62,0	459,0	153,0	315,0	104,0
BSTK50-DBTT-R	62,0	134,0	153,0	459,0	104,0	315,0

Bearings for ball screw drives can be exposed to axial and radial loads. To calculate the static safety and the nominal service lifetime, it is necessary to determine the static and dynamic equivalent load. To determine the equivalent loads, the instructions for calculating the BST axial angular contact ball bearings in Chapter 6.1.1.1 must be used.

For the calculation of ball screws, the rigidity and starting torque of the bearings must be considered. Depending on the bearing arrangement and the sealing, these values are summarized in Table 6.7

Table 6.7 Starting torque for SNR Fixed bearing unit BSTK

Type	Starting moment [Nm]
BSTK17-DB	0,215
BSTK20-DB	0,215
BSTK25-DB	0,365
BSTK30-DB	0,365
BSTK30-DTBT	0,745
BSTK35-DB	0,380
BSTK35-DBT-A	0,510
BSTK35-DBT-R	0,510
BSTK40-DB	1,155
BSTK40-DBT-A	1,570
BSTK40-DBT-R	1,570
BSTK50-DTBT	2,815
BSTK50-DBTT-A	2,175
BSTK50-DBTT-R	2,175

Information on the various versions of the standard end machining can be found in Chapter 6.2.1.1.

6.1.1.3 Fixed bearings for Ball Screws with mounting holes in the outer ring type BSTU

The NTN bearings of the BSTU series are double-row axial angular contact ball bearings with a 60 ° contact angle, which have been specially developed for ball screws, in which the outer rings of two axial angular contact ball bearings are combined to form a unit in an DB arrangement. As a fixed bearing for ball screw drives, they meet the highest requirements in terms of load ratings. By through holes in the outer ring is a very simple assembly is given. The BSTU bearing units can be installed as single bearings (Figure 6.5) or paired for the highest loads in D2 configuration (Figure 6.6).

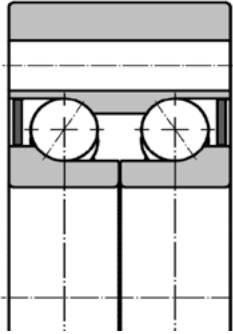

Figure 6.5 BSTU Bearing unit

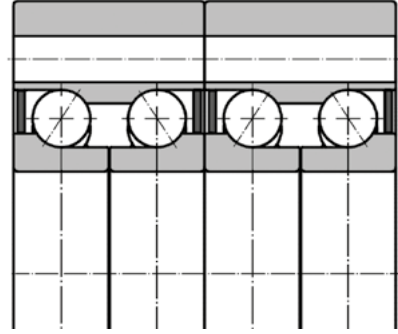

Figure 6.6 BSTU_D2 Bearing unit

Bearings of the BSTU series are equipped with light-contact seals (LXL) and filled with a special grease (L588). The instructions in Chapter 3.3.2.3 must be observed for assembly.

The type code has the following structure:

BSTU 20 68 LXL D2 / GN P4U / L588

1 2 3 4 5 / 6 7 / 8

1	BSTU	Product BSTU: Double row NTN angular contact ball bearings with 60° contact angle
2	20	Bore diameter [mm]
3	68	Outer diameter [mm]
4	LXL	Sealing options LXL: Light contact rubber seal
5	D2	Arrangement without: one bearing D2: two paired bearings
6	GN	Preload GN: Standard preload
7	P4	Precision class P4U: NTN Standard P42U: increased precision
8	L588	Grease code L588: Standard grease with Urea based special grease

The dimensions and load ratings of the double row axial angular contact ball bearings of the BSTU series suitable for SNR ball screws are summarized in Figure 6.7, Table 6.8 and Table 6.9.

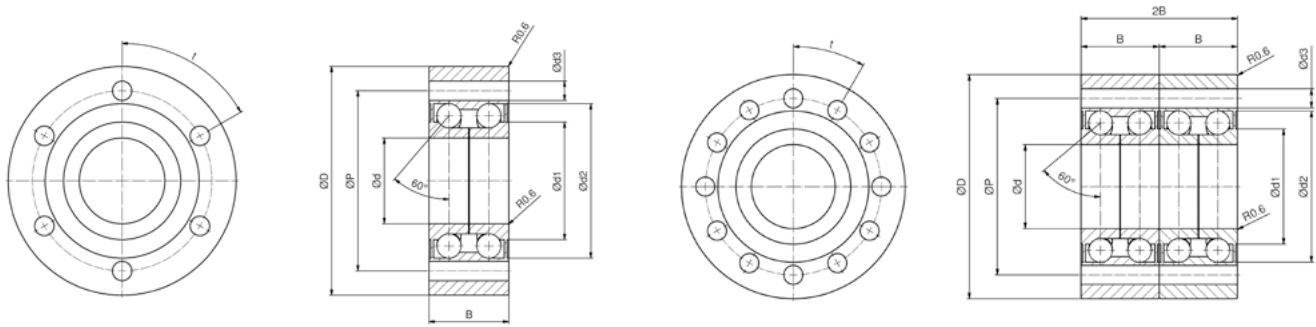

Figure 6.7 ___ Double row axial angular contact ball bearings BSTU and BSTU_D2

Table 6.8 ___ Dimension double row NTN angular contact ball bearings BSTU and BSTU_D2

Type	ID Number	Shaft		d	D	B	r _{min}	P	d ₃	d ₁	d ₂	D _{a max.} ¹	d _{a max.} ²	t	Mass
		d ₀ [mm]	P [mm]												
BSTU2068LLX	381455	32	10	20	68	28	0,6	53	6,8	30,1	43,0	42	26	90	0,60
BSTU2068LLXD2	287403													45	1,20
BSTU2575LLX	256040	32	4/5/20/32	25	75	28	0,6	58	6,8	36,1	49,0	48	32	90	0,72
BSTU2575LLXD2	267666													45	1,44
BSTU3080LLX	237541	40	all	30	80	28	0,6	63	6,8	41,1	54,0	53	37	60	0,78
BSTU3080LLXD2	234758													30	1,56
BSTU40100LLX	on request	50	5/50	40	100	34	0,6	80	8,8	54,1	68,9	68	49	90	1,46
BSTU40100LLXD2	247262													45	1,92
BSTU50115LLX	on request	63/80	all	50	115	55	0,6	94	8,8	68,1	82,9	82	62	60	1,87

¹ Maximum diameter of the contact edge of the outer ring

² Maximum diameter of the contact edge of the shaft end

Table 6.9 ___ Load ratings double row NTN angular contact ball bearings BSTU and BSTU_D2

Type	Basic dynamic load rating C _a [kN]	Basic static load rating C _{0a} [kN]	Allowable axial load [kN]	Limiting speed (Grease lubrication) [min ⁻¹]
BSTU2068LLX	31,0	48,0	24,0	6 000
BSTU2068LLXD2	50,5	96,0	48,0	
BSTU2575LLX	34,0	58,0	28,5	5 000
BSTU2575LLXD2	55,0	116,0	57,0	
BSTU3080LLX	36,5	68,5	33,0	4 500
BSTU3080LLXD2	59,0	137,0	65,0	
BSTU40100LLX	52,0	106,0	50,5	3 500
BSTU40100LLXD2	84,0	212,0	101,0	
BSTU50115LLX	57,0	135,0	65,0	2 800

Further dimensions and information on the NTN axial angular contact ball bearings of the BSTU series can be found in the NTN catalog "Precision Rolling Bearings", Chapter "Ball Screw Support Bearings".

Bearings for ball screw drives can be exposed to axial and radial loads. To calculate the static safety and the nominal service lifetime, it is necessary to determine the static and dynamic equivalent load.

The static equivalent load is calculated according to Formula [6.3]. It must be ensured that the equivalent static load is smaller than the maximum static axial load.

$$P_{0a} = F_a + 3,98F_r$$

[Formula 6.3]

- P_a** Equivalent static load [kN]
- F_a** Maximum axial load [kN]
- F_r** Maximum radial load [kN]

The dynamic equivalent load is calculated according to Formula [6.4]. The correction factors X and Y are based on the ratio of axial load to radial load and the arrangement of the bearings. The correction factors can be found in Table 6.10.

$$P_a = XF_r + YF_a$$

[Formula 6.4]

- P_a** Equivalent dynamic load [kN]
- F_a** Maximum axial load [kN]
- F_r** Maximum radial load [kN]
- X** Correction factor
- Y** Correction factor

Table 6.10 ___ Correction factors for the calculation of the dynamic equivalent load

		BSTU	BSTU_D2
$F_a / F_r \leq 2,17$	X	1,90	-
	Y	0,55	-
$F_a / F_r > 2,17$	X	0,92	0,92
	Y	1,00	1,00

For the calculation of ball screws, the rigidity and bearing friction torque of the bearings must be considered. Depending on the bearing arrangement and the sealing, these values are summarized in Table 6.11.

Table 6.11 ___ Bearing friction torque and rigidity of double row NTN angular contact ball bearings BSTU and BSTU_D2

Type	Bearing friction torque [Nm]	Preload [kN]	Axial bearing rigidity [N/μm]	Rigidity against moment [Nm/mrad]	Mass moment of inertia [kgcm ²]
BSTU2068LLX	0,2	2 100	675	150	0,25
BSTU2068LLXD2	0,5	4 200	1 350	340	0,50
BSTU2575LLX	0,3	2 400	790	230	0,45
BSTU2575LLXD2	0,5	4 800	1 580	510	0,90
BSTU3080LLX	0,3	2 700	900	315	0,68
BSTU3080LLXD2	0,6	5 400	1 800	690	1,36
BSTU40100LLX	0,4	3 200	1 050	610	2,16
BSTU40100LLXD2	0,8	6 350	2 100	1 310	4,32
BSTU50115LLX	0,5	3 800	1 300	1 080	5,06

Information on the various versions of the standard end machining can be found in Chapter 6.2.1.2.

6.1.1.4 Floating bearing unit for Ball Screws in block design type BSTF

The bearing units of the BSTF series are floating bearing units in block design, which are adapted to the height of the fixed bearing units BSTK (Figure 6.8).

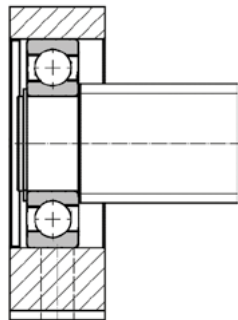

Figure 6.8___ Floating bearing unit BSTF

Bearing units of the BSTF series are equipped with axially displaceable deep groove ball bearings with seals. The instructions in Chapter 3.3.3 must be observed for installation.

The dimensions of the floating bearing units of the BSTF series suitable for SNR ball screws are summarized in Figure 6.9, Table 6.12.

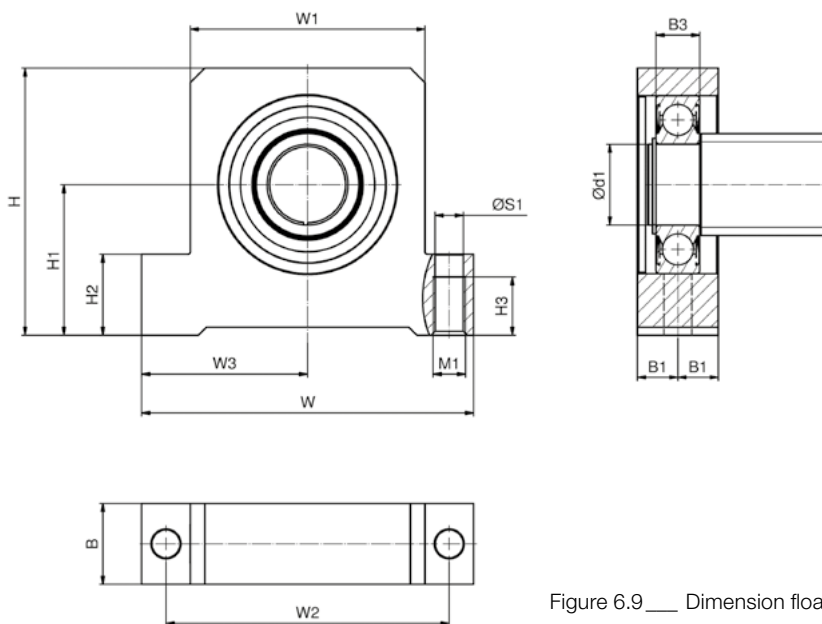

Figure 6.9___ Dimension floating bearing unit BSTF

Table 6.12___ Dimension floating bearing unit BSTF

Type	ID Number	d_0 [mm]	P [mm]	d_1 [mm]	H [mm]	H_1 $\pm 0,02$ [mm]	H_2 [mm]	Chamfer [mm]	H_3 [mm]	W [mm]	W_3 [mm]	W_1 [mm]	W_2 [mm]	B [mm]	B_1 [mm]	B_3 [mm]	S_1 [mm]	M_1	Mass
BSTF17	478449	25	5/10/25	17	72	39	27	4	18	108	54,0	66	88	28	14	12	10,2	M 12	1,0
BSTF20	478450	32	10	20	77	42	27	5	18	112	56,0	70	92	34	17	15	10,2	M 12	1,3
BSTF25	478451	32	4/5/20/32	25	77	42	27	5	18	112	56,0	70	92	34	17	15	10,2	M 12	1,3
BSTF30	478452	40	5/10/25	30	91	50	32	4	21	126	63,0	82	105	38	19	16	11,0	M 14	1,8
BSTF35	478453	50	10/20	35	105	58	38	5	22	144	72,0	92	118	41	20,5	17	13,0	M 16	2,6
BSTF40	478454	50	50	40	138	73	50	10	22	190	95,0	130	160	46	23	23	13,0	M 16	5,6
BSTF50	478455	63 / 80	10/20	50	165	93	50	9	36	205	102,5	145	175	50	25	27	17,5	M 20	7,5

6.1.1.5 Self-locking precision nut type PRS

Self-locking precision nuts are required for the assembly and adjustment of the preload of fixed bearings of ball screw drives for high loads. We recommend the use of SNR precision nuts type PRS (Figure 6.10).

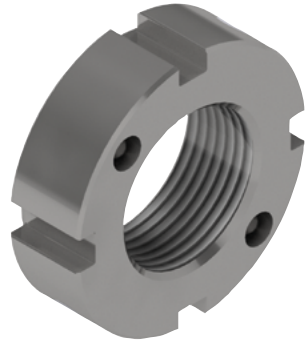

Figure 6.10 __ Self-locking precision nut PRS

The precision nuts are fixed using 2 radially arranged set screws. These cause the blocking elements made of a soft material to lock into the thread of the end machining. The dimensions and tightening torque for the self-locking precision nuts type PRS are summarized in Figure 6.11, Table 6.13.

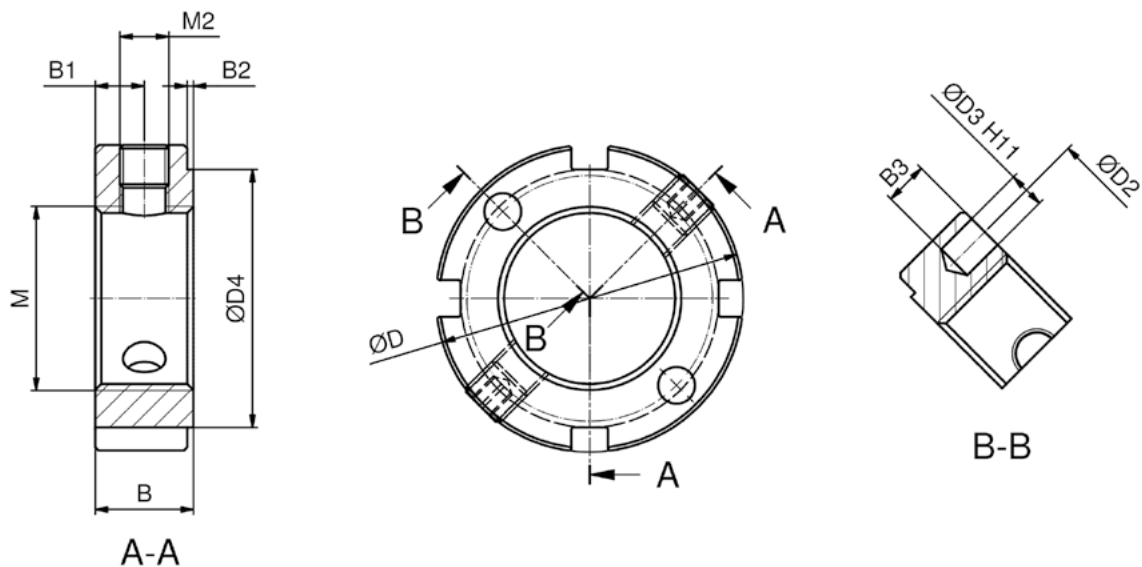

Figure 6.11 __ Dimension self-locking precision PRS

Table 6.13 ___ Dimension and tightening torque for self-locking precision nut PRS

Typ	ID Number	d_0	P	M	M_2	D	D_2	D_3	D_4	B	B_1	B_2	B_3	M_a	M_{bl}	M_d	F_{ar}	Mass
		[mm]	[mm]			[mm]	[mm]	[mm]	[mm]	[mm]	[mm]	[mm]	[mm]	[mm]	[mm]	[Nm]	[Nm]	[Nm]
PRS10	255258	14	all	M10x1	M4	18	14,0	2,5	14	8	4	0,5	3,5	6	1,0	28	35	8
		16	4/5															
PRS12	255260	16	10/16	M12x1	M4	22	17,0	2,5	18	8	4	0,5	3,5	8	1,0	31	47	15
		20	4/5															
PRS15	255262	20	10/20	M15x1	M4	25	20,0	3,0	21	8	4	0,5	3,5	10	1,0	32	65	20
PRS17	255264	25	5/10/25	M17x1	M5	28	22,5	3,0	23	10	5	0,5	4,0	15	3,0	32	100	24
PRS20	255266	32	10	M20x1	M5	32	26,0	3,0	27	10	5	0,5	4,0	18	5,0	39	140	40
PRS25	255267	32	4/5/20/32	M25x1	M6	38	31,0	3,0	33	12	6	0,5	4,0	25	8,0	56	198	61
PRS30	255269	40	5/10/25	M30x1,5	M6	45	37,5	4,0	40	12	6	0,5	5,0	32	8,0	63	240	84
PRS35	255420	50	10/20	M35x1,5	M6	52	42,0	4,0	47	12	6	0,5	5,0	40	9,0	72	263	111
PRS40	255421	50	50	M40x1,5	M6	58	48,0	4,0	52	14	7	0,5	5,0	65	9,0	97	290	153
PRS50	255422	63 / 80	10/20	M50x1,5	M6	70	60,0	4,0	64	14	7	0,5	5,0	85	10,0	132	351	210

- M_a Tightening torque for M
- M_{bl} Tightening torque for M2
- M_d Torque to loosen the secured nut
- F_{ar} Axial rupture load

6.1.2 Bearing units for Ball screws with low and medium loads

6.1.2.1 Fixed bearing unit for Ball Screws in block design type BK / EK

The fixed bearing units for ball screws of the BK and EK series are block type bearing units for low and medium loads. The bearing units are equipped with axial angular contact ball bearings with a 25 ° or 40° contact angle (except EK05_C7) in DF configuration (Figure 6.12). The specially ground side surfaces give the bearings the required preload when installed.

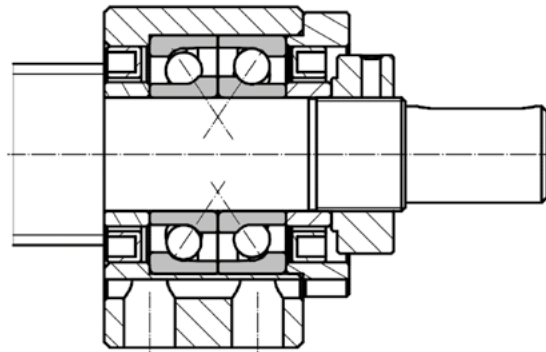

Figure 6.12 __ Bearing arrangement DF in fixed bearing units BK and EK

Bearings of the fixed bearing units of the series BK and EK are equipped with sealing shields as standard. The instructions in Chapter 3.3.3.4 must be observed for installation.

The dimensions, load ratings and tightening torque of the fixed bearing units of the BK and EK series suitable for SNR ball screws are summarized in Figure 6.13, Table 6.14 and Table 6.15.

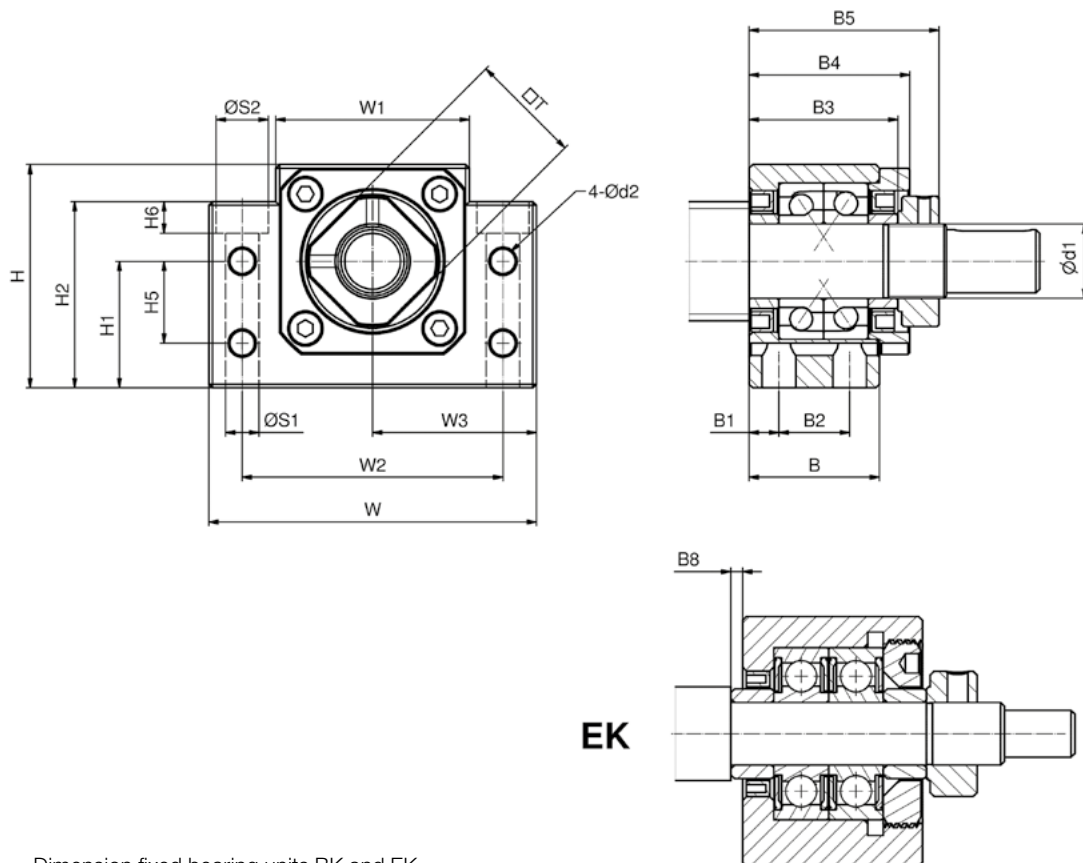

Figure 6.13 __ Dimension fixed bearing units BK and EK

Table 6.14 ___ Dimension fixed bearing units BK and EK

Type	ID Number	d ₀ [mm]	P [mm]	d ₁ [mm]	H [mm]	H ₁ ±0,02 [mm]	H ₂ [mm]	W [mm]	W ₃ ±0,02 [mm]	W ₁ [mm]	W ₂ [mm]	B [mm]	B ₁ [mm]	B ₂ [mm]	B ₃ [mm]	B ₄ [mm]	B ₅ [mm]	B ₈ [mm]	S ₁ [mm]	S ₂ [mm]	H ₆ [mm]	d ₂ [mm]	H ₅ [mm]	□ _T [mm]	Mass [kg]
EK05_C7	264255	6	all	5	21	11	8,0	36	18	20	28	16,5	8,25	-	17,0	-	22,0	0,0	4,5	-	-	-	-	11	0,12
EK06_C5	485529	8	all	6	25	13	20,0	42	21	18	30	21,5	11,50	-	22,0	-	27,0	1,5	5,5	9,5	11,0	-	-	12	0,18
EK08_C5	485530	10	all	8	32	17	26,0	52	26	25	38	24,5	13,00	-	25,0	-	31,5	1,5	6,6	11,0	12,0	-	-	14	0,27
		12	all																						
BK10_C5	485531	14	all	10	39	22	32,5	60	30	34	46	25,0	6,00	13	26,5	30,2	34,5	0,0	6,6	10,8	5,0	5,5	15	16	0,40
		16	4/5																						
BK12_C5	485532	16	10/16	12	43	25	32,5	60	30	34	46	25,0	6,00	13	26,5	30,2	34,5	0,0	6,6	10,8	5,0	5,5	18	19	0,45
BK15_C5	485533	20	10/20	15	48	28	38,0	70	35	40	54	27,0	6,00	15	30,0	33,0	38,0	21,0	6,6	11,0	6,5	5,5	18	22	0,69
BK17_C5	485534	25	alle	17	64	39	55,0	86	43	50	68	35,0	8,00	19	38,0	44,2	51,0	28,0	9,0	14,0	8,5	6,6	28	24	1,30
BK20_C5	485535	32	10	20	60	34	50,0	88	44	52	70	35,0	8,00	19	40,0	43,2	51,0	27,0	9,0	14,0	8,5	6,6	22	30	1,30
BK25B_C5	485536	32	4/5/20/32	26	80	48	70,0	106	53	64	85	42,0	10,00	22	48,0	54,2	63,0	33,0	11,0	17,0	11,0	9,0	33	35	2,40
BK30B_C5	485537	40	all	30	89	51	78,0	128	64	76	102	45,0	11,00	23	50,0	59,2	70,0	36,0	14,0	20,0	13,0	11,0	33	40	3,40
BK35_C5	485538	50	10/20	35	96	52	79,0	140	70	88	114	50,0	12,00	26	58,0	64,2	79,0	38,0	14,0	20,0	13,0	11,0	35	50	4,40
BK40_C5	485539	50	50	40	110	60	90,0	160	80	100	130	61,0	14,00	33	66,0	79,2	91,0	46,0	18,0	26,0	17,5	14,0	37	50	6,80

Table 6.15 ___ Load ratings fixed bearing units BK and EK

Type	d ₀ [mm]	P [mm]	Bearing type	Contact angle [°]	Basic dynamic load rating C _a [kN]	Basic static load rating C _{0a} [kN]	Static axial load capacity [kN]	Axial spring constant k [N/μm]	Starting torque [Nm]
EK05_C7	6	all	605	0	0,76	0,26	0,15	15	0,004
EK06_C5	8	all	706A P0	30	2,03	0,80	0,73	31	0,005
EK08_C5	10	all	708A P0	30	3,30	1,44	1,02	51	0,009
	12	all							
BK10_C5	14	all	7000A P5	30	5,00	2,33	2,00	91	0,019
	16	4/5							
BK12_C5	16	10/16	7001A P5	30	5,05	2,46	2,38	91	0,021
	20	4/5							
BK15_C5	20	10/20	7002A P5	30	5,75	3,10	2,90	111	0,023
BK17_C5	25	all	7203A P5	30	10,50	5,40	4,07	120	0,037
BK20_C5	32	10	7204A P5	30	13,30	7,70	5,79	147	0,038
BK25B_C5	32	4/5/20/32	7205B P0	40	14,80	9,40	8,90	169	0,073
BK30B_C5	40	all	7206B P0	40	20,50	13,50	12,50	179	0,105
BK35_C5	50	10/20	7207B P0	40	27,10	18,40	16,50	193	0,132
BK40_C5	50	50	7208B P0	40	32,00	23,00	20,90	218	0,205

6.1.2.2 Fixed bearing unit for Ball Screws in flange design type FK

The fixed bearing units for ball screws of the FK series are flange type bearing units for low and medium loads. The bearing units are equipped with axial angular contact ball bearings with a 25 ° or 40° contact angle (except FK05_C7) in DF configuration (Figure 6.14). The specially ground side surfaces give the bearings the required preload when installed.

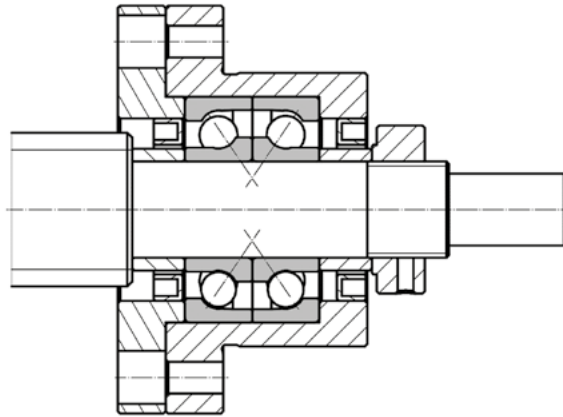

Figure 6.14 __ Bearing arrangement DF in fixed bearing units FK

Bearings of the fixed bearing units of the series FK are equipped with sealing shields as standard. The instructions in Chapter 3.3.3.5 must be observed for installation.

The dimensions, load ratings and tightening torque of the fixed bearing units of the BK and EK series suitable for SNR ball screws are summarized in Figure 6.15, Table 6.16 and Table 6.17.

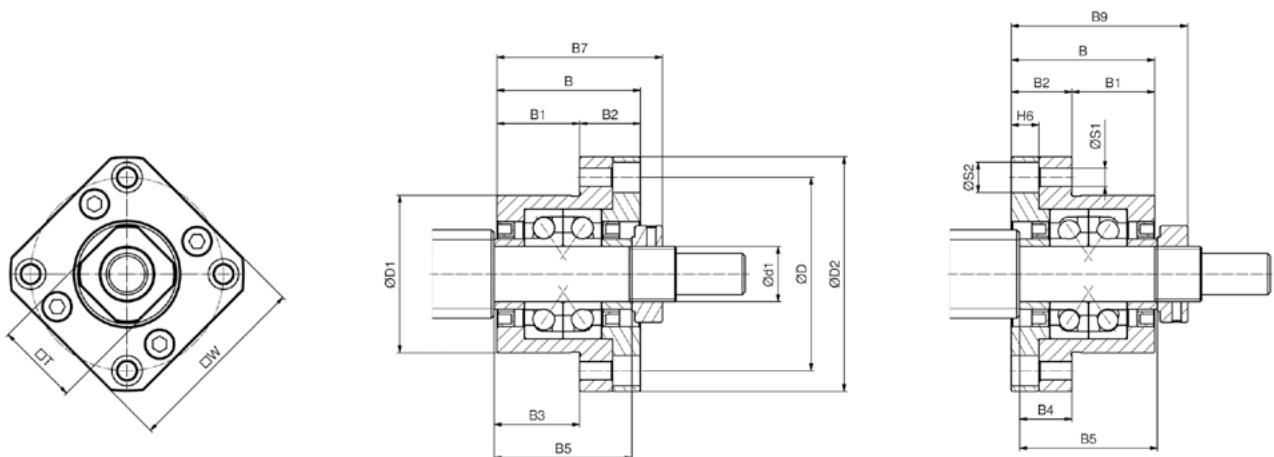

Figure 6.15 __ Dimension fixed bearing units FK

Table 6.16 ___ Dimension fixed bearing units FK

Type	ID Number	d ₀ [mm]	P [mm]	d ₁ [mm]	□ W [mm]	D ₁ g6 [mm]	D ₂ [mm]	∅D [mm]	B [mm]	B ₁ [mm]	B ₂ [mm]	B ₃ [mm]	B ₄ [mm]	B ₅ [mm]	B ₇ [mm]	B ₉ [mm]	S ₁ [mm]	S ₂ [mm]	H ₆ [mm]	□ T [mm]	Mas [mm]
FK05_C7	in preparation	6	all	5	26	20	34,0	26	16,5	10,5	6	10,5	6,5	-	11,0	11,5	3,4	6,5	3,5	11	0,08
FK06_C5	in preparation	8	all	6	28	22	36,0	28	20,0	13,0	7	14,5	7,5	22	14,5	13,5	3,4	6,5	4,0	12	0,10
FK08_C5	485650	10	all	8	35	28	43,0	35	23,0	14,0	9	15,5	9,5	25	16,0	16,0	3,4	6,5	4,0	14	0,15
		12	all																		
FK10_C5	485651	14	all	10	42	34	52,0	42	27,0	17,0	10	17,5	9,5	27	19,5	18,5	4,5	8,0	4,0	16	0,23
		16	4/5																		
FK12_C5	485652	16	10/16	12	44	36	54,0	44	27,0	17,0	10	17,5	9,5	27	19,5	18,5	4,5	8,0	4,0	19	0,25
		20	4/5																		
FK15_C5	485653	20	10/20	15	52	40	63,0	50	32,0	17,0	15	21	17	38	22,0	20,0	5,5	9,5	6,0	22	0,39
FK17_C5	in preparation	25	all	17	61	50	77,0	62	45,0	23,0	22	24	20	44	34,0	31,0	6,6	11,0	10,0	24	0,81
FK20_C5	485654	32	10	20	68	57	85,0	70	52,0	30,0	22	31	19	50	44,0	40,0	6,6	11,0	10,0	30	1,02
FK25B_C5	485655	32	4/5/20/32	26	79	63	98,0	80	57,0	30,0	27	31	19	58	44,0	37,0	9,0	15,0	13,0	35	1,48
FK30B_C5	485656	40	alle	30	93	75	117,0	95	62,0	32,0	30	29	21	50	51,0	45,0	11,0	17,5	15,0	40	2,32

Table 6.17 ___ Load ratings fixed bearing units FK

Type	d ₀ [mm]	P [mm]	Bearing type	Contact angle [°]	Basic dynamic load rating C _a [kN]	Basic static load rating C _{0a} [kN]	Static axial load capacity [kN]	Axial spring constant k [N/μm]	Starting torque [Nm]
FK05_C7	6	all	605	0	0,76	0,26	0,15	15	0,004
FK06_C5	8	all	706A P0	30	2,03	0,80	0,73	31	0,005
FK08_C5	10	all	708A P0	30	3,30	1,44	1,02	51	0,009
	12	all							
FK10_C5	14	all	7000A P5	30	5,00	2,33	2,00	91	0,019
	16	4/5							
FK12_C5	16	10/16	7001A P5	30	5,05	2,46	2,38	91	0,021
	20	4/5							
FK15_C5	20	10/20	7002A P5	30	5,75	3,10	2,90	111	0,023
FK17_C5	25	all	7203A P5	30	10,50	5,40	4,07	120	0,037
FK20_C5	32	10	7204A P5	30	13,60	7,55	5,79	147	0,038
FK25B_C5	32	4/5/20/32	7205B P0	40	14,80	9,40	8,90	169	0,073
FK30B_C5	40	all	7206B P0	40	20,50	13,50	12,50	179	0,105

6.1.2.3 Floating bearing unit for Ball Screws in block design type BF / EF

The bearing units of the BF and EF series are floating bearing units in block design, which are adapted to the height of the fixed bearing units BK and EK (Figure 6.16).

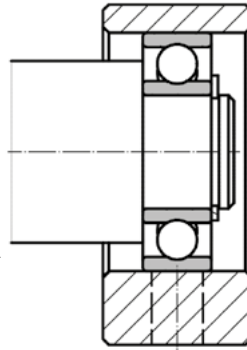

Figure 6.16 __ Dimension floating bearing unit BF and EF

Bearing units of the BF and EF series are equipped with axially displaceable deep groove ball bearings with sealing shields. The instructions in Chapter 3.3.3 must be observed for installation.

The dimensions of the floating bearing units of the BF and EF series suitable for SNR ball screws are summarized in Figure 6.17, Table 6.18.

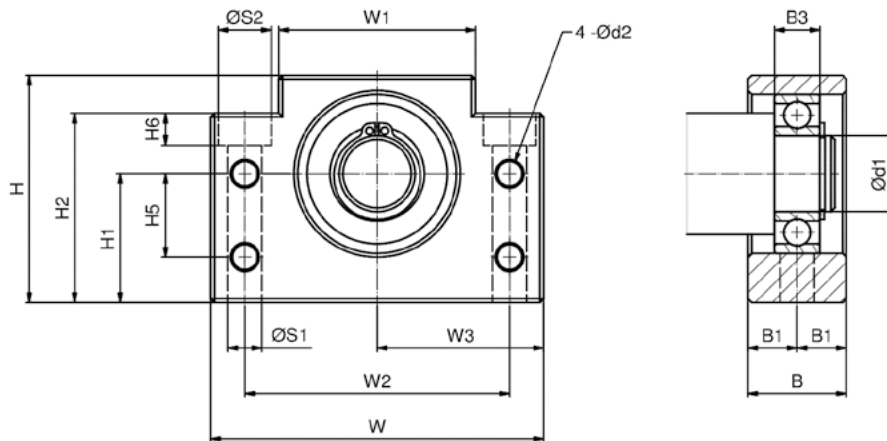

Figure 6.17 __ Dimension floating bearing unit BF and EF

Table 6.18 __ Dimension floating bearing unit BF and EF

Typ	ID Number	d_0	P	d_1	H	H_1 $\pm 0,02$	H_2	W	W_3 $\pm 0,02$	W1	W2	B	B1	B ₃	S ₁	S ₂	H ₆	d_2	H ₅	Mass
		[mm]	[mm]	[mm]	[mm]	[mm]	[mm]	[mm]	[mm]	[mm]	[mm]	[mm]	[mm]	[mm]	[mm]	[mm]	[mm]	[mm]	[mm]	[kg]
EF06_C3	485540	8	all	6	25	13	20,0	42	21	18	30	12,0	6,0	6,0	5,5	9,5	11,0	-	-	0,10
EF08_C3	485541	10	all	6	32	17	26,0	52	26	25	38	14,0	7,0	6,0	6,6	11,0	12,0	-	-	0,16
		12	all																	
BF10_C3	485542	14	all	8	39	22	32,5	60	30	34	46	20,0	10,0	7,0	6,6	10,8	5,0	5,5	15	0,30
		16	4/5																	
BF12_C3	485543	16	10/16	10	43	25	32,5	60	30	34	46	20,0	10,0	8,0	6,6	10,8	1,5	5,5	18	0,35
		20	4/5																	
BF15_C3	485643	20	10/20	15	48	28	38,0	70	35	40	54	20,0	10,0	9,0	6,6	11,0	6,5	5,5	18	0,40
BF17_C3	485644	25	all	17	64	39	55,0	86	43	50	68	23,0	11,5	12,0	9,0	14,0	8,5	6,6	28	0,75
BF20_C3	485645	32	10	20	60	34	50,0	88	44	52	70	26,0	13,0	12,0	9,0	14,0	8,5	6,6	22	0,77
BF25_C3	485646	32	4/5/20/32	26	80	48	70,0	106	53	64	85	30,0	15,0	15,0	11,0	17,0	11,0	9,0	33	1,45
BF30_C3	485647	40	all	30	89	51	78,0	128	64	76	102	32,0	16,0	16,0	14,0	20,0	13,0	11,0	33	1,95
BF35_C3	485648	50	10/20	35	96	52	79,0	140	70	88	114	32,0	16,0	17,0	14,0	20,0	13,0	11,0	35	2,25
BF40_C3	485649	50	50	40	110	60	90,0	160	80	100	130	37,0	18,5	18,0	18,0	26,0	17,5	14,0	37	3,30

6.1.2.4 Floating bearing unit for Ball Screws in flange design type FF

The bearing units of the FF series are floating bearing units in flange design (Figure 6.18).

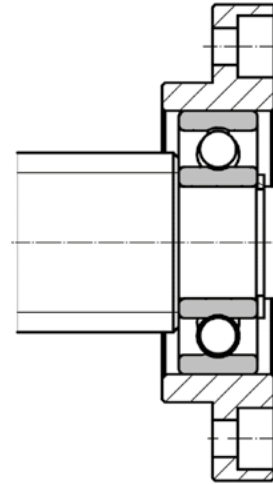

Figure 6.18 __ Floating bearing unit FF

Bearing units of the FF series are equipped with axially displaceable deep groove ball bearings with sealing shields. The instructions in Chapter 3.3.3 must be observed for installation.

The dimensions of the floating bearing units of the FF series suitable for SNR ball screws are summarized in Figure 6.19, Table 6.19.

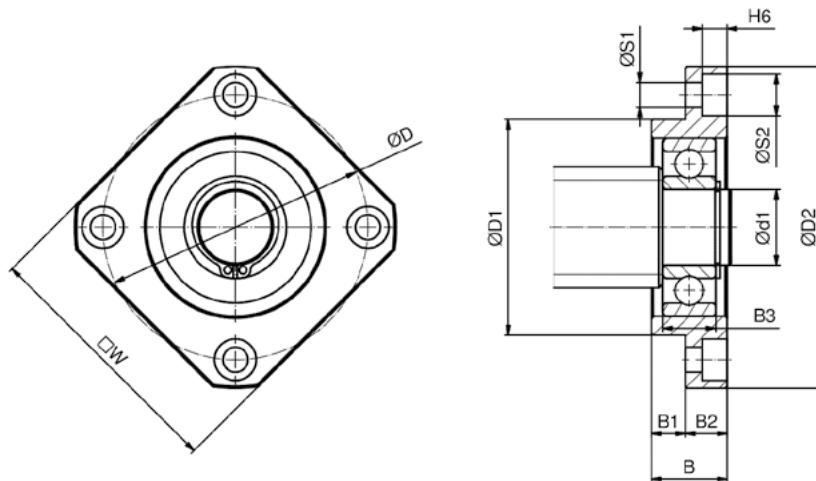

Figure 6.19 __ Dimension floating bearing unit FF

Table _____ 6.19 Dimension floating bearing unit FF

Type	ID-Nummer	d ₀ [mm]	P [mm]	d ₁ [mm]	□ W [mm]	D ₁ g6 [mm]	D ₂ [mm]	D [mm]	B [mm]	B ₁ [mm]	B ₂ [mm]	B ₃ [mm]	S ₁ [mm]	S ₂ [mm]	H ₆ [mm]	Mass [kg]
FF06_C3	485657	8	all	6	28	22	36,0	28	10	4	6	6	3,4	6,5	3,5	0,06
FF10_C3	485658	10	all	8	35	28	43,0	35	12	5	7	7	3,4	6,5	4,0	0,10
		12	all													
FF12_C3	485659	14	all	10	42	34	52,0	42	15	8	7	8	4,5	8,0	4,0	0,13
		16	all													
		20	4/5													
FF15_C3	485660	20	10/20	15	52	40	63,0	50	17	8	9	9	5,5	9,5	5,5	0,20
FF17_C3	in preparation	25	all	17	61	50	77,0	62	20	9	11	12	6,6	11,0	6,5	0,33
FF20_C3	485661	32	10	20	68	57	85,0	70	20	9	11	14	6,6	11,0	6,5	0,43
FF25_C3	485662	32	4/5/20/32	26	79	63	98,0	80	24	10	14	15	9,0	14,0	8,5	0,66
FF30_C3	485663	40	all	30	93	75	117,0	95	27	9	18	16	11,0	17,0	11,0	1,03

6.1.2.5 Self-locking precision nut type

Self-locking precision nuts are required for the assembly and adjustment of the preload of fixed bearings of ball screw drives for low and medium loads. We recommend the use of SNR precision nuts type PRN (Figure 6.20).

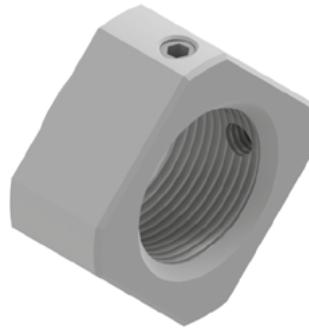

Figure 6.20__ Self-locking precision nut PRN

The precision nuts are fixed using 2 radially arranged set screws. These cause the blocking elements made of a soft material to lock into the thread of the end machining. The dimensions and tightening torque for the self-locking precision nuts type PRN are summarized in Figure 6.21, Table 6.20

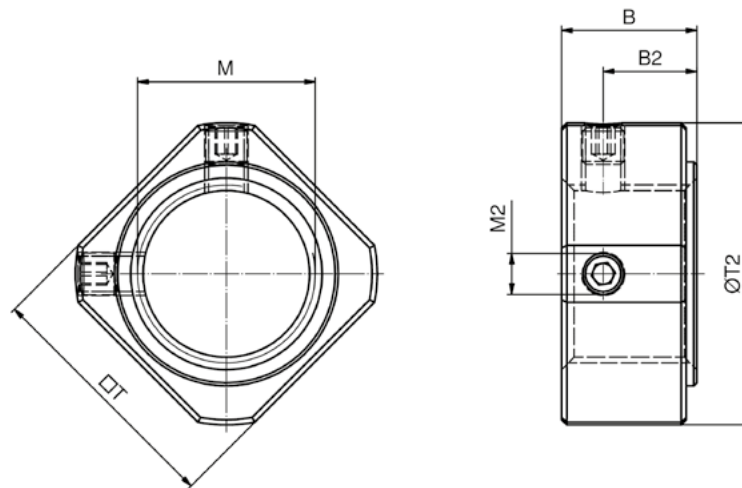

Figure 6.21__ Dimension self-locking precision nut PRN

Table 6.20 __ Dimension and tightening torque for self-locking precision nut PRN

Type	ID Number	T	T ₂	L	L ₂	M	M _a	M ₂	M _{bl}	Mass
		[mm]	[mm]	[mm]	[mm]		[Nm]		[Nm]	
PRN06	485664	12	13,5	5,0	2,70	M6x0,75	2,5	M3x0,5	0,6	0,006
PRN08	485665	14	16,0	6,5	4,00	M8x1,0	5,0	M3x0,5	0,6	0,010
PRN10	485666	16	19,0	8,0	5,50	M10x1,0	9,5	M3x0,5	0,6	0,017
PRN12	485667	19	22,0	8,0	5,50	M12x1,0	14,0	M4x0,7	1,5	0,024
PRN15	485668	22	25,0	8,0	4,75	M15x1,0	24,0	M4x0,7	1,5	0,032
PRN17	485669	24	29,0	13,0	9,00	M17x1,0	31,5	M4	1,5	0,066
PRN20	485670	30	35,0	11,0	7,00	M20x1,0	48,0	M4	1,5	0,085
PRN25	485671	35	43,0	15,0	10,00	M25x1,5	86,0	M6	5,0	0,168
PRN30	485672	40	48,0	20,0	14,00	M30x1,5	128,0	M6	5,0	0,287
PRN35	485673	50	60,0	21,0	14,00	M35x1,5	200,0	M6	5,0	0,476
PRN40	485674	50	62,0	25,0	18,00	M40x1,5	300,0	M6	5,0	0,584

M_a Tightening torque for M
M_{bl} Tightening torque for M₂

6.2 Standard end machining

There are various standard end machinings for the bearings for Ball Screws described in Chapter 6.1. The designation of the standard end machining consists of the version, the design and the diameter of the bearing seat, e.g. F115.

Version of standard end machinings

- D:**D: Standard end machining for fixed bearing unit FK (Chapter 6.2.1.4, Table 6.24)
- E:**Standard end machining for fixed bearings BST_DB and fixed bearing units BSTK_DB (Chapter 6.2.1.1, Table 6.21)
- F:**Standard end machining for fixed bearing unit BK, EK (Chapter 6.2.1.3, Table 6.23)
- G:**Standard end machining for fixed bearing unit BSTK_DBT (Chapter 6.2.1.1, Table 6.21)
- J:**Standard end machining for fixed bearings BST_DTBT/DBTT and fixed bearing units BSTK_DTBT/DBTT (Chapter 6.2.1.1, Table 6.21)
- K:**Standard end machining for fixed bearings BSTU (Chapter 6.2.1.2, Table 6.22)
- L:**Standard end machining for fixed bearings BSTU_D2 (Chapter 6.2.1.2, Table 6.22)
- M:**Standard end machining for fixed bearings BST_DBT (Chapter 6.2.1.1, Table 6.21)
- S:**Standard end machining for floating bearings (Chapter 6.2.2, Table 6.25)
- 0:**without end machining
- X:**Special end machining according drawing

Options of standard end machinings

Fixed bearing

- 1:**Standard end machining without additional options
- 2:**Standard end machining with additional key way
- 5:**Standard end machining with additional hexagon socket
- 6:**Standard end machining with additional hexagon socket and key way
- 7:**Standard end machining with additional across flat
- 8:**Standard end machining with additional across flat and key way

Floating bearing

- 1...3:** ...Standard end machining for floating bearings

Other

- 0:**without end machining
- X:**special end machining according drawing

Shaft diameter of the standard end machining [mm]

- [value]:** Standard end machining
- 00:**without end machining
- XX:**special end machining

6.2.1 Standard end machining for fixed bearings

6.2.1.1 Standard end machining for fixed bearings BST and fixed bearing units BSTK

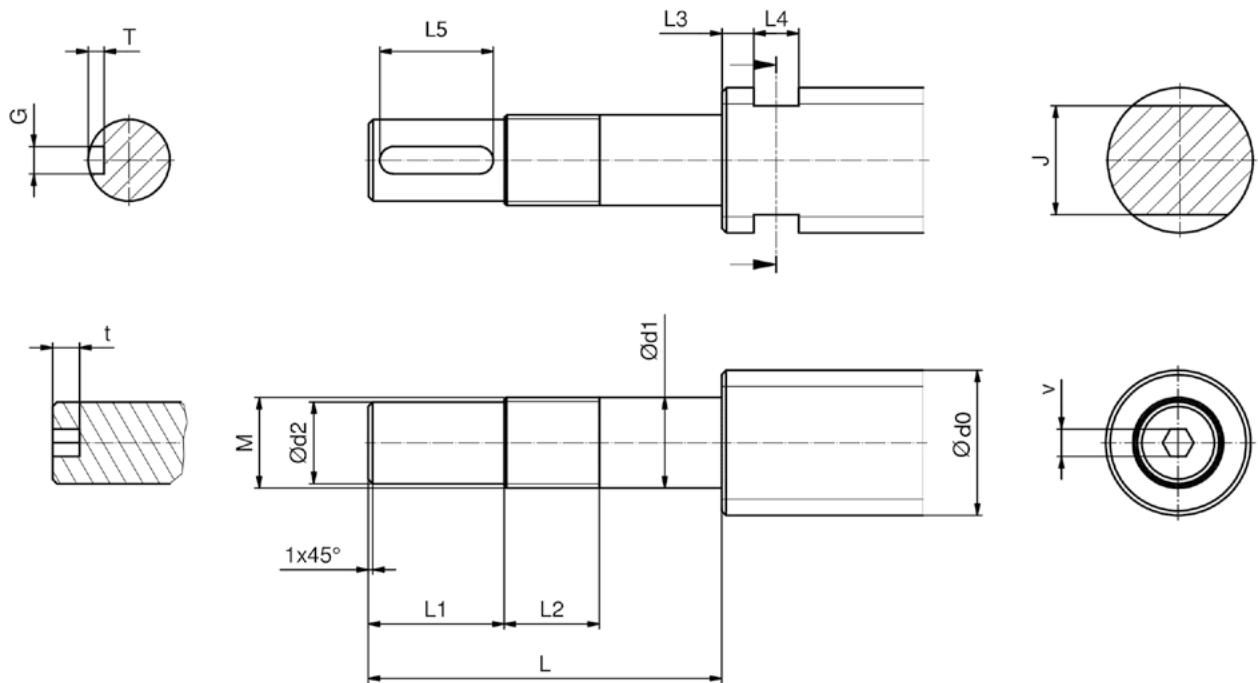

Figure 6.22__ Dimension standard end machining for BST bearings and BSTK bearing units

Table 6.21 __ Dimension standard end machining for BST bearings and BSTK bearing units

Type	Version	d ₀	P	d ₁ h6	d ₃ h7	L	L ₁	L ₂	M	T	G	L ₅	J	L ₄	L ₃	V	t
		[m]	[mm]	[mm]	[mm]	[mm]	[mm]	[mm]	[vmm]	[mm]	[mm]	[mm]	[mm]	[mm]	[mm]	[mm]	[mm]
2 x BST17x47-1B LXL P4/L588	BSTK17-DB	E1	25	all	17	15	73	28	18	M17x1	3,0	5	22				
		E2															
		E5															
		E6															
		E7															
E8																	
2 x BST20x47-1B LXL P4/L588	BSTK20-DB	E1	32	10	20	18	78	30	21	M20x1,5	3,5	6	25				
		E2															
		E5															
		E6															
		E7															
E8																	
2 x BST25x62-1B LXL P4/L588	BSTK25-DB	E1	32	4 / 5 / 20 / 32	25	22	80	32	22	M25x1,5	3,5	6	25				
		E2															
		E5															
		E6															
		E7															
E8																	
2 x BST30x62-1B LXL P4/L588	BSTK30-DB	E1	40	all	30	25	84	35	23	M30x1,5	4,0	8	25				
		E2															
		E5															
		E6															
		E7															
E8																	
4 x BST30x62-1B LXL P4/L588	BSTK30-DBDT	J1	40	all	30	25	84	35	23	M30x1,5	4,0	8	25				
		J2															
		J5															
		J6															
		J7															
J8																	
2 x BST35x72-1B LXL P4/L588	BSTK35-DB	E1	50	10 / 20	35	30	102	40	21	M35x1,5	4,0	8	32				
		E2															
		E5															
		E6															
		E7															
E8																	
3 x BST35x72-1B LXL P4/L588	BSTK35-DBT-A BSTK35-DBT-R	G1	50	10 / 20	35	30	102	40	21	M35x1,5	4,0	8	32				
		G2															
		G5															
		G6															
		G7															
G8																	
2 x BST40x90-1B LXL P4/L588	BSTK40-DB	E1	50	5 / 50	40	36	134	60	18	M40x1,5	5,0	10	40				
		E2															
		E5															
		E6															
		E7															
E8																	
3 x BST40x90-1B LXL P4/L588	BSTK40-DBT-A BSTK40-DBT-R	G1	50	5 / 50	40	36	134	60	18	M40x1,5	5,0	10	40				
		G2															
		G5															
		G6															
		G7															
G8																	
4 x BST50x100-1B LXL P4/L588	BSTK50-DBDT BSTK50-DBTT-A BSTK50-DBTT-R	M1	63 / 80	all	50	40	161	70	15	M50x1,5	5,0	12	50				
		M2															
		M5															
		M6															
		M7															
M8																	
		J1	63 / 80	all	50	40	161	70	15	M50x1,5	5,0	12	50				
		J2															
		J5															
		J6															
		J7															
J8																	

6.2.1.2 Standard end machining for fixed bearings BSTU

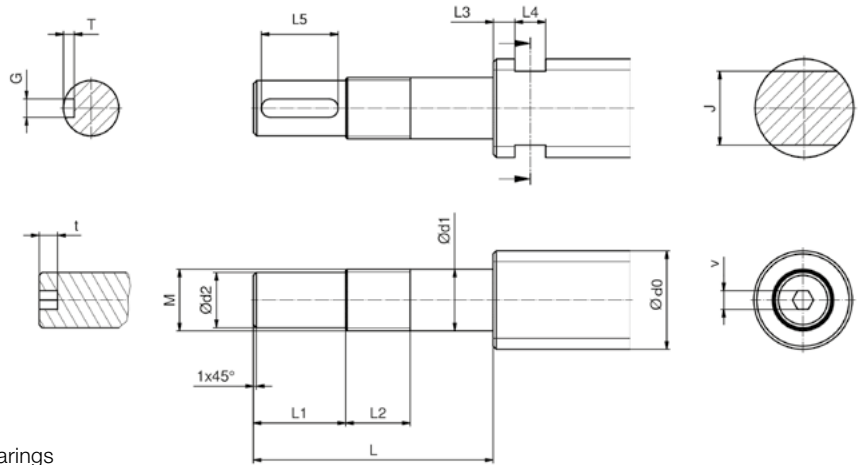

Figure 6.23__
Dimension standard end machining for BSTU bearings

Table 6.22 __ Dimension standard end machining for BSTU bearings

Type	Version	d ₀	P	d ₁ h6	d ₃ h7	L	L ₁	L ₂	M	T	G	L ₅	J	L ₄	L ₃	V	t					
		[m]	[mm]	[mm]	[mm]	[mm]	[mm]	[mm]	[mm]	[vmm]	[mm]	[mm]	[mm]	[mm]	[mm]	[mm]	[mm]	[mm]				
BSTU2068LLX	K1	32	10	20	18	25	30	22,0	M20x1,5	3,0	5	21					4	4				
	K2																					
	K5																					
	K6																					
BSTU2068LLXD2	K7					32	10	20	18	25	30	22,0	M20x1,5	3,0	5	21	18	10	7			
	K8																					
	L1																					
	L2																					
BSTU2068LLXD2	L5	32	10	20	18					53			M20x1,5	3,0	5	21					4	4
	L6																					
	L7																					
	L8																					
BSTU2575LLX	K1					32	4 / 5 / 20 / 32	25	22	25	35	23,8	M25x1,5	3,5	6	25					6	6
	K2																					
	K5																					
	K6																					
BSTU2575LLXD2	K7	32	4 / 5 / 20 / 32	25	22					25	35	23,8	M25x1,5	3,5	6	25	27	13	9			
	K8																					
	L1																					
	L2																					
BSTU2575LLXD2	L5					32	4 / 5 / 20 / 32	25	22	53			M25x1,5	3,5	6	25					6	6
	L6																					
	L7																					
	L8																					
BSTU3080LLX	K1	40	all	30	25					25	38	28,3	M30x1,5	4,0	8	32						
	K2																					
	K5																					
	K6																					
BSTU3080LLXD2	K7					40	all	30	25	25	38	28,3	M30x1,5	4,0	8	32	32	15	10			
	K8																					
	L1																					
	L2																					
BSTU3080LLXD2	L5	40	all	30	25					53			M30x1,5	4,0	8	32					10	10
	L6																					
	L7																					
	L8																					
BSTU40100LLX	K1					50	5 / 50	40	30	30	40	25,3	M40x1,5	5,0	10	45					10	10
	K2																					
	K5																					
	K6																					
BSTU40100LLXD2	K7	50	5 / 50	40	30					30	40	25,3	M40x1,5	5,0	10	45	41	19	14			
	K8																					
	L1																					
	L2																					
BSTU40100LLXD2	L5					50	5 / 50	40	30	64			M40x1,5	5,0	10	45					10	10
	L6																					
	L7																					
	L8																					
BSTU50115LLX	K1	63 / 80	all	50	40					30	70	20,8	M50x1,5	5,0	12	50					17	17
	K2																					
	K5																					
	K6																					
BSTU50115LLX	K7					63 / 80	all	50	40	30	70	20,8	M50x1,5	5,0	12	50	55	22	16			
	K8																					
	L1																					
	L2																					
BSTU50115LLX	L5	63 / 80	all	50	40					30	70	20,8	M50x1,5	5,0	12	50					17	17
	L6																					
	L7																					
	L8																					
BSTU50115LLX	L1					63 / 80	all	50	40	30	70	20,8	M50x1,5	5,0	12	50	55	22	16			
	L2																					
	L3																					
	L4																					

6.2.1.3 Standard end machining for fixed bearing units BK / EK

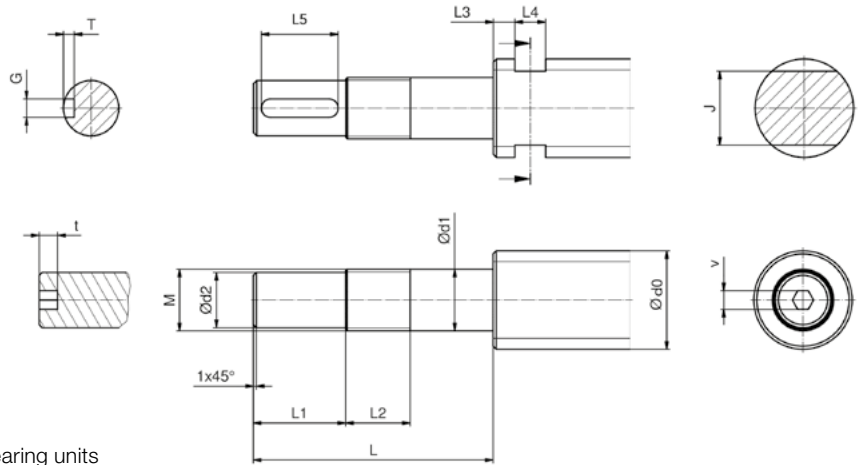

Figure 6.24 __
Dimension standard end machining for BK and EK bearing units

Table 6.23 __ Dimension standard end machining for BK and EK bearing units

Type	Version	d_0	P	d_1 h6	d_3 h7	L	L_1	L_2	M	T	G	L_5	J	L_4	L_3	V	t						
		[mm]	[mm]	[mm]	[mm]	[mm]	[mm]	[mm]	[mm]	[mm]	[mm]	[mm]	[mm]	[mm]	[mm]	[mm]	[mm]						
EK05_C7	F1	6	all	5	4	31,0	6	7,0	M5x0,5														
EK06_C5	F1	8	all	6	4	38,0	8	8,0	M6x0,75														
EK08_C5	F1	10	all	8	6	44,0	9	10,0	M8x1														
EK08_C5	F1	12	all	8	6	44,0	9	10,0	M8x1														
BK10_C5	F1	14	all	10	8	54,0	15	16,0	M10x1														
	F2																						
	F1	16	4 / 5																				
	F2									1,2	2	11											
BK12_C5	F1	16	10 / 16	12	10	54,0	15	14,0	M12x1														
	F2									1,8	3	12											
	F7												13	8	6								
	F8									1,8	3	12	13	8	6								
	F1	20	4 / 5																				
	F2									1,8	3	12											
	F7												13	8	6								
	F8									1,8	3	12	13	8	6								
BK15_C5	F1	20	10 / 20	15	12	60,0	20	15,0	M15x1														
	F2									2,5	4	16							4	4			
	F5																				4	4	
	F6									2,5	4	16											
	F7												16	9	6								
	F8									2,5	4	16	16	9	6								
BK17_C5	F1	25	all	17	15	76,0	23	20,0	M17x1														
	F2									3,0	5	21							4	4			
	F5																				4	4	
	F6									3,0	5	21											
	F7												18	10	7								
BK20_C5	F1	32	10	20	15	78,0	25	19,0	M20x1														
	F2									3,0	5	21							6	6			
	F5																				6	6	
	F6									3,0	5	21	18	10	7								
BK25B_C5	F1	32	4 / 5 / 20 / 32	25	20	95,0	30	18,0	M25x1,5														
	F2									3,5	6	25							6	6			
	F5																				6	6	
	F6									3,5	6	25											
	F7												27	13	9								
BK30B_C5	F1	40	all	30	25	110,0	38	25,0	M30x1,5														
	F2									4,0	8	32							10	10			
	F5																				10	10	
	F6									4,0	8	32											
	F7												32	15	10								
BK35_C5	F1	50	10 / 20	35	30	128,0	45	28,0	M35x1,5														
	F2									4,0	8	32								10	10		
	F5																				10	10	
	F6									4,0	8	32											
	F7												32	15	10								
BK40_C5	F1	50	5 / 50	40	35	148,0	50	35,0	M40x1,5														
	F2									5,0	10	45								10	10		
	F5																				10	10	
	F6																						
	F7												41	19	14								
F8	5,0	10	45	41	19	14																	

6.2.1.4 Standard end machining for fixed bearing units FK

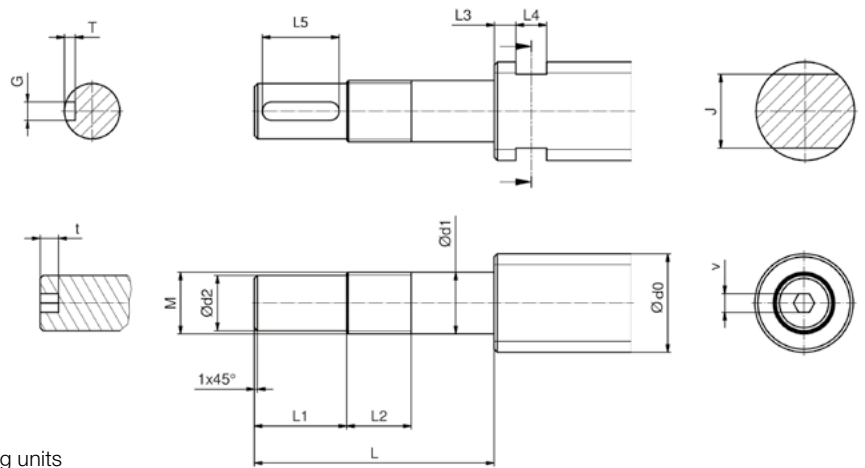

Figure 6.25__
Dimension standard end machining for FK bearing units

Table 6.24 __ Dimension standard end machining for FK bearing units

Type	Version	d ₀	P	d ₁ h6	d ₃ h7	L	L ₁	L ₂	M	T	G	L ₅	J	L ₄	L ₃	V	t	
		[mm]	[mm]	[mm]	[mm]	[mm]	[mm]	[mm]	[mm]	[mm]	[mm]	[mm]	[mm]	[mm]	[mm]	[mm]	[mm]	
FK05_C7	D1	6	all	5	4	31,0	6	7,0	M5x0,5									
FK06_C5	D1	8	all	6	4	38,0	8	8,0	M6x0,75									
FK08_C5	D1	10	all	8	6	44,0	9	10,0	M8x1									
FK08_C5	D1	12	all	8	6	44,0	9	10,0	M8x1									
FK10_C5	D1	14	all	10	8	51	15	11	M10x1	1,2	2	11						
	D2																	
	D1	16	4 / 5															
	D2																	
FK12_C5	D1	16	10 / 16	12	10	51	15	11	M12x1	1,8	3	12		13	8	6		
	D2																	
	D7																	
	D8																	
	D1	20	4 / 5										13	8	6			
	D2																	
	D7																	
	D8																	
FK15_C5	D1	20	10 / 20	15	12	64	20	15	M15x1	2,5	4	16		16	9	6		
	D2																	
	D7																	
	D5																	
	D6																	
	D8																	
FK17_C5	D1	25	all	17	15	83	23	18	M17x1	3,0	5	21					4	4
	D2																	
	D5																	
	D6																	
	D7																	
D8																		
FK20_C5	D1	32	10	20	15	91	25	17	M20x1	3,0	5	21					6	6
	D2																	
	D5																	
	D6																	
	D7																	
	D8																	
FK25B_C5	D1	32	4 / 5 / 20 / 32	25	20	107	30	24	M25x1,5	3,5	6	25					6	6
	D2																	
	D5																	
	D6																	
	D7																	
D8																		
FK30B_C5	D1	40	all	30	25	118	38	21	M30x1,5	4,0	8	32					10	10
	D2																	
	D5																	
	D6																	
	D7																	
D8																		

6.2.2 Standard end machining for floating bearing units

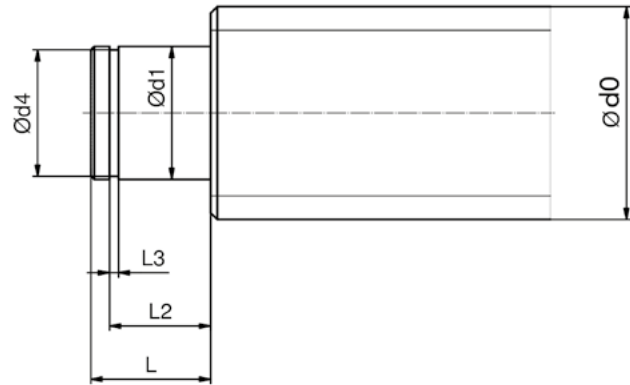

Figure 6.26__
Dimension standard end machining for BSTF, BF and FF bearing units

Table 6.25 __ Dimension standard end machining for BSTF, BF and FF bearing units

Type	Version	d_0	P	d_1	d_3		L	$L_2^{+0,2}$	L_3
		[m]	[mm]	h_7 [mm]	[mm]	[mm]	[mm]	[mm]	H_{13} [mm]
EF06_C3	S1	8	all	6	5,7	h10	8	6,80	0,80
FF06_C3		10	all						
EF08_C3		12	all						
BF10_C3	S1	14	all	8	7,6	h10	9	7,90	0,90
FF10_C3		16	4/5						
BF12_C3	S1	16	10/16	10	11,5	h11	11	9,10	1,10
FF12_C3		20	4/5						
BF15_C3	S1	20	10/20	15	14,3	h11	13	10,10	1,10
FF15_C3									
BF17_C3	S1	25	all	17	16,2	h11	16	13,10	1,10
FF17_C3									
BSTF17									
BF20_C3	S1	32	10	20	19,0	h11	16	13,30	1,30
FF20_C3	S2						18	15,30	
BSTF20	S3						20	16,30	
BF25_C3	S1	32	4/5/20/32	25	23,9	h11	20	16,30	1,30
FF25_C3									
BSTF25									
BF30_C3	S1	40	all	30	28,6	h11	21	17,60	1,60
FF30_C3									
BSTF30									
BF35_C3	S1	50	10/20	35	33,0	h12	22	18,60	1,60
BSTF35									
BF40_C3	S1	50	5/50	40	38,0	h12	24	19,85	1,85
BSTF40	S2						28	24,85	
BSTF50	S2	63 / 80	all	50	47,0	h12	27	29,15	2,15

6.3 Coupling cones

The fixed bearing units BSTK are designed so that standard coupling cones can be mounted directly on the front site. The dimension of the coupling cones are shown in Figure 6.27 and summarized in Table 6.26.

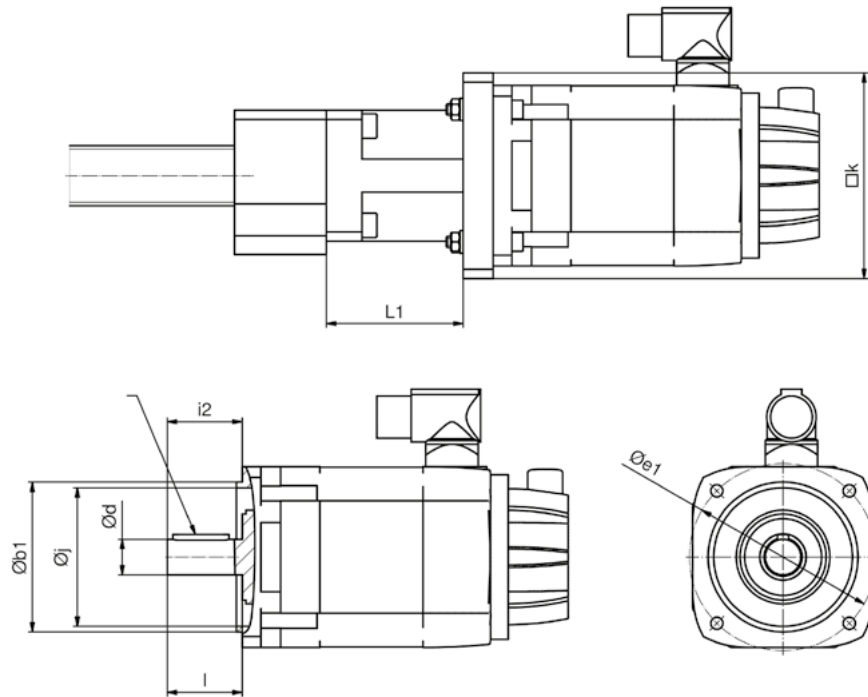

Figure 6.27 __ Dimension of standard coupling cones for BSTK bearing units

Table 6.26 __ Dimension of standard coupling cones for BSTK bearing units

Type	Design type	$e1_{min.}$	$e1_{max.}$	$b1_{min.}$	$b1_{max.}$	$d_{min.}$	$d_{max.}$	$i2_{max.}$	$i2_{max.-l}$	k	L1	Maximum drive torque [Nm]
		[mm]	[mm]	[mm]	[mm]	[mm]	[mm]	[mm]	[mm]			
BSTK17	B5 / B14	63	100	50	80	9	19 ²	40	3	82	76,0	17,0
	B5	115	130	95	110	19	20	40	15	110	88,0	17,0
		130	130	110	110	24	24	50	25	120	98,0	17,0
BSTK20	B5 / B14	75	130	60 ¹	110	14	24 ²	50	3	112	89,0	60,0
BSTK25		165	165	130	130	32	32	60	28	155	130,5	60,0

¹ For drives with smaller centering, the centering by the drive adapter omitted

6.4 Deflection belt drive

A combination of the fixed bearing units BSTK with standard deflection belt drives is provided for limited installation space. The dimensions of the available deflection belt drives are shown in Figure 6.28 and summarized in Table 6.27. The arrangement of the deflection belt drive can be offset by 90° as shown in Figure 6.29.

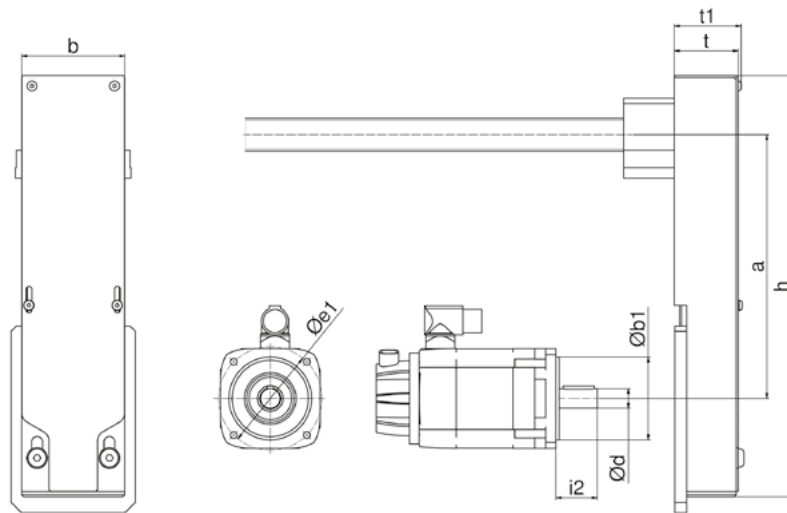

Figure 6.28__ Dimension of standard deflection belt drives for BSTK bearing units

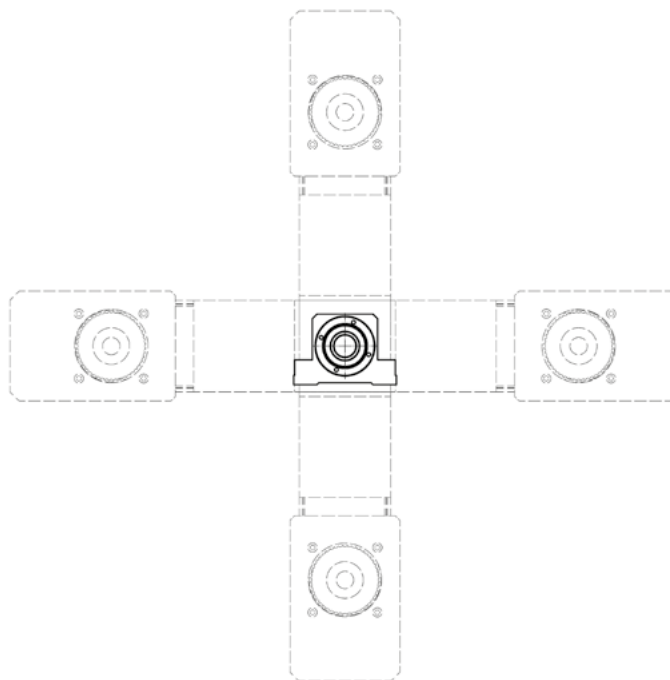

Figure 6.29__ Arrangement of standard deflection belt drives for BSTK bearing units

Table 6.27 __ Dimension of standard deflection belt drives for BSTK bearing units

Type	b1 [mm]		e1 [mm]		i2 [mm]		Design type	a [mm]	a1 [mm]	b [mm]	h [mm]	t [mm]	t1 [mm]
	min.	max.	min.	max.	min.	max.							
BSTK17	50 ¹	80	63	100	20	50	B5	185 ± 2,5	39,0	80	267	60	67
BSTK20 BSTK25	60 ¹	110	75	130	30	50	B5 / B14	249,5 ± 5,5	57,0	100	407	60	67

¹ For drives with smaller centering, the centering by the drive adapter omitted

6.5 Lubrication connection

Flange type nuts of Ball Screws from diameter 16 are designed with a threaded hole in the flange, which can be equipped with a grease nipple or a tube connection. The screw-in nuts BNU2505_SH_4 have a threaded connection in the cylindrical nut body. Table 6.28 contains an overview of the available lubrication connections and their dimensions.

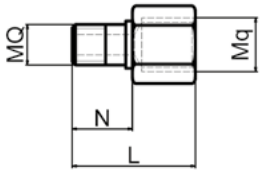
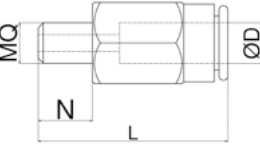
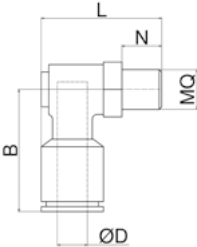
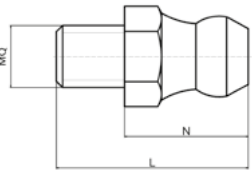
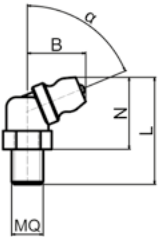
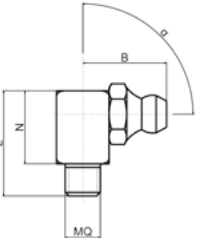
Type	Dimension	Designation SNR	ID number	MQ	Mq	N	L	B	α	$\varnothing D$
						[mm]	[mm]	[mm]		[mm]
Extention		LE-M6-G1/8x15,4	250158	M6	G1/8	6,0	15,4	-	0°	-
		LE-M6-M5x13	274968	M6	M5	3,6	13,0	-	0°	-
		LE-M6-M8x15,4	250414	M6	M8	6,0	15,4	-	0°	-
		LE-M6-M8x1x15,4	250419	M6	M8x1	6,0	15,4	-	0°	-
		LE-M8x1-M8x1x22	on request	M8x1	G1/4	8,0	22,0	-	0°	-
Tube connection straight		LH-M6x5A-4	244379	M6	-	5,0	16,0	-	0°	4
		LH-M6x5A-6	244380	M6	-	5,0	16,0	-	0°	6
		Steckverschraubung-M8x1-D6-gerade	295839	M8x1	-	6,0	24,3	-	0°	6
Tube connection swiveling		LH-M6x5S-4	270991	M6	-	5,0	22,5	18,0	90°	4
		LH-M6x5S-6	262033	M6	-	5,0	22,5	18,0	90°	6
		PUSH-IN-GIR.90 M8X1 TUBO4_3084731	311560	M8x1	-	8,0	25,5	22,0	90°	4
		PUSH-IN 90 M8X1 D6 - HP_3084752	330086	M8x1	-	8,0	24,2	24,5	90°	6
Grease nipple, hydraulic type		GRN-M6-5,0-Z-0	253082	M6	-	10,2	15,2	-	0°	-
		GRN-M8x1-5,5-Z-0	on request	M8x1	-	9,5	15,0	-	0°	-
		GRN-M6-5,5-K-45	253121	M6	-	18,0	23,5	10,5	45°	-
		GRN-M8x1-5,5-K-45	on request	M8x1	-	15,0	20,5	10,5	45°	-
		GRN-M6-5,0-Z-67	258143	M6	-	13,5	18,5	11,4	67°	-
		GRN-M8x1-5,5-K-67	on request	M8x1	-	12,0	17,5	12,3	67°	-
		GRN-M6-5,5-K-90	258143	M6	-	12,5	18,0	13,0	90°	-
		GRN-M8x1-5,5-K-90	on request	M8x1	-	5,5	18,0	13,0	90°	-

7. Corrosion protection / Coatings

If corrosion protection is required, SNR Ball Screws from diameter 16 can be supplied with DURALLOY® TDC coating.

Characteristics of DURALLOY® TDC coating:

- Specific thin chrome coating
- Thickness 2,5...4 µm
- No deformation of the parts
- Crack free layer with extreme high hardness (800...1300 HV), very good corrosion resistant
- Color: matt grey

We recommend contacting our NTN-SNR application engineers to select a suitable corrosion protection.

8. Type code

Ball Screw:

$\frac{\text{BSC}}{1} \frac{020}{2} \frac{05}{3} \frac{\text{R}}{4} \frac{\text{CI}}{5} \frac{\text{LL}}{6} \frac{2}{7} \frac{\text{Z}}{8} \frac{\text{T5}}{9} \frac{\text{W}}{10} \frac{\text{Z0}}{11} - \frac{1000}{12} - \frac{\text{F}}{13} \frac{1}{14} \frac{15}{15} - \frac{\text{S}}{16} \frac{1}{17} \frac{15}{18} - \frac{\text{A}}{19} \frac{0}{20} \frac{0}{21}$

Ball Screw shaft:

$\frac{\text{BSH}}{1} \frac{020}{2} \frac{05}{3} \frac{\text{R}}{4} \frac{00}{5} \frac{\text{T5}}{9} \frac{\text{W}}{10} - \frac{1000}{12} - \frac{\text{F}}{13} \frac{1}{14} \frac{15}{15} - \frac{\text{S}}{16} \frac{1}{17} \frac{15}{18} - \frac{\text{B}}{19} \frac{0}{20} \frac{0}{21}$

Ball Screw nut:

$\frac{\text{BNU}}{1} \frac{020}{2} \frac{05}{3} \frac{\text{R}}{4} \frac{\text{CI}}{5} \frac{\text{LL}}{6} \frac{2}{7} \frac{\text{Z}}{8} - \frac{\text{A}}{19} \frac{0}{21}$

1	BSC	Product BSC:Ball Screw BSH:Ball Screw shaft BNU:Ball Screw nut
2	020	Nominal diameter [mm]
3	05	Pitch [mm]
4	R	Pitch direction R:right L:left
5	CI	Ball Screw nut type CD:Compact cylindrical single nut CI:Cylindrical single nut DC:Compact double nut with flange according DIN ISO 69051 SC:Compact single nut with flange according DIN ISO 69051 SH:Screw-in nut SK:Miniature single nut with flange SU:Single nut with flange according DIN ISO 69051 TW:Single nut with pitch offset and flange according DIN ISO 69051 Ball Screw shaft type 00:for nut type CI, SH, SK, SU, TW 01:for nut type CD, DC, SC
6	LL	Sealing options AA:without seals LL:Labyrinth seals UU:Lip seals
7	2	Number of circuits (round down at decimals)
8	Z	Flange type A:Flange type A according DIN ISO 69051 (round) B:Flange type B according DIN ISO 69051 (double-side cut) C:Flange type C according DIN ISO 69051 (one-side cut) Z:Cylindrical nut
9	T7	Tolerance class T3*, T5, T7, T10*: Tolerance class for transport Ball Screws P3*, P5: Tolerance class for position Ball Screws * on request
10	R	Manufacturing process G:Grinded (on request) R:Rolled (tolerance class T7, T10) W:Whirled (tolerance class T3, T5, T7, P3, P5)
11	Z0	Preload class Z0:Standard axial clearance Z1:without axial clearance Z2:light preload Z3:medium preload Z4:high preload
12	1000	Total length [mm]

13	F	Version of the right shaft end <i>see Chapter 6.2</i>	
14	1	Options of the right shaft end <i>see Chapter 6.2</i>	
15	15	Bearing seat diameter of the right shaft end [mm] <i>see Chapter 6.2</i>	
16	S	Version of the left shaft end <i>see Chapter 6.2</i>	
17	1	Options of the left shaft end <i>see Chapter 6.2</i>	
18	15	Bearing seat diameter of the left shaft end [mm] <i>see Chapter 6.2</i>	
19	A	Lubricant A:SNR LUB HEAVY DUTY (Standard) B:Without lubricant, only with anti-corrosion oil Contracor Fluid H1 C:SNR LUB HIGH SPEED+ D:SNR LUB HIGH TEMP E:SNR LUB FOOD AL F:Microlube GL261 (Klüber Lubrication) G:Klübersynth BEM34-32 (Klüber Lubrication) H:Klübersynth UH1 14-151 (Klüber Lubrication) N:Without lubricant, without anti-corrosion X:Special lubricant according customer request	
20	0	Options 0:without options 1:with drive torque protocol 2:with pitch error protocol 3:with drive torque and pitch error protocol	
21	0	Special versions 0:without special options A...Y:according drawing or text description (index is given from NTN-SNR)	

9. Type list

		Page
BF...	Floating bearing unit for Ball Screws, block design	92
BK...	Fixed bearing unit for Ball Screws, block design	88, 89
BNU_CD...	Compact cylindrical single nut	72
BNU_CI...	Cylindrical single nut	71
BNU_DC...	Compact double nut, flange design according DIN ISO 39051	68
BNU_SC...	Compact single nut, flange design according DIN ISO 39051	67
BNU_SH...	Screw-in nut	73
BNU_SK...	Miniature nut, flange design	74
BNU_SU...	Single nut, flange design according DIN ISO 39051	69
BNU_TW...	Single nut with pitch offset, flange design according DIN ISO 39051	70
BNU...	Ball Screw nut	67 - 74
BSC...	Ball Screw	106, 107
BSH...	Ball Screw shaft	62 - 65
BST...	Angular contact ball bearings with 60 ° contact angle	75 - 78
BSTF...	Floating bearing unit for Ball Screws, block design	85
BSTK...	Fixed bearing unit for Ball Screws, block design	79 - 81
BSTU...	Fixed bearing unit for Ball Screws with mounting holes in the outer ring	82 - 84
EF...	Floating bearing unit for Ball Screws, block design	92
EK...	Fixed bearing unit for Ball Screws, block design	88, 89
FF...	Floating bearing unit for Ball Screws, flange design	93
FK...	Fixed bearing unit for Ball Screws, flange design	90, 91
PRN...	Self-locking precision nut	96, 87
PRS...	Self-locking precision nut	94
-	Coupling cone	102
-	Deflection belt drive	103

10. Fits

Shaft tolerance [μm]

over	up to	d9	e8	f7	f6	f5	g6	g5	h5	h6	h7	h8	h9	h10
-	3	-20	-14	-6	-6	-6	-2	-2	0	0	0	0	0	0
		-45	-28	-16	-12	-10	-8	-6	-4	-6	-10	-14	-25	-40
3	6	-30	-20	-10	-10	-10	-4	-4	0	0	0	0	0	0
		-60	-38	-22	-18	-15	-12	-9	-5	-8	-12	-18	-30	-48
6	10	-40	-25	-13	-13	-13	-5	-5	0	0	0	0	0	0
		-76	-47	-28	-22	-19	-14	-11	-6	-9	-15	-22	-36	-58
10	18	-50	-32	-16	-16	-16	-6	-6	0	0	0	0	0	0
		-93	-59	-34	-27	-24	-17	-14	-8	-11	-18	-27	-43	-70
18	30	-65	-40	-20	-20	-20	-7	-7	0	0	0	0	0	0
		-117	-73	-41	-33	-29	-20	-16	-9	-13	-21	-33	-52	-84
30	50	-80	-50	-25	-25	-25	-9	-9	0	0	0	0	0	0
		-142	-89	-50	-41	-36	-25	-20	-11	-16	-25	-39	-62	-100
50	80	-100	-60	-30	-30	-30	-10	-10	0	0	0	0	0	0
		-174	-106	-60	-49	-43	-29	-23	-13	-19	-30	-46	-74	-120
80	120	-120	-72	-36	-36	-36	-12	-12	0	0	0	0	0	0
		-207	-126	-71	-58	-51	-34	-27	-15	-22	-35	-54	-87	-140
120	180	-145	-85	-43	-43	-43	-14	-14	0	0	0	0	0	0
		-245	-148	-83	-68	-61	-39	-32	-18	-25	-40	-63	-100	-160
180	250	-170	-100	-50	-50	-50	-15	-15	0	0	0	0	0	0
		-285	-172	-96	-79	-70	-44	-35	-20	-29	-46	-72	-115	-185
250	315	-190	-110	-56	-56	-56	-17	-17	0	0	0	0	0	0
		-320	-191	-108	-88	-79	-49	-40	-23	-32	-52	-81	-130	-210
315	400	-210	-125	-62	-62	-62	-18	-18	0	0	0	0	0	0
		-350	-214	-119	-98	-87	-54	-43	-25	-36	-57	-89	-140	-230

Bore tolerance [μm]

over	up to	D10	E9	F6	F7	F8	G6	G7	H5	H6	H7	H8	H9	H10
-	3	+60	+39	+12	+16	+20	+8	+12	+4	+6	+10	+14	+25	+40
		+20	+14	+6	+6	+10	+2	+2	0	0	0	0	0	0
3	6	+78	+50	+18	+22	+28	+12	+16	+5	+8	+12	+18	+30	+48
		+30	+20	+10	+10	+10	+4	+4	0	0	0	0	0	0
6	10	+98	+61	+22	+28	+35	+14	+20	+6	+9	+15	+22	+36	+58
		+40	+25	+13	+13	+13	+5	+5	0	0	0	0	0	0
10	18	+120	+75	+27	+34	+43	+17	+24	+8	+11	+18	+27	+43	+70
		+50	+32	+16	+16	+16	+6	+6	0	0	0	0	0	0
18	30	+149	+92	+33	+41	+53	+20	+28	+9	+13	+21	+33	+52	+84
		+65	+40	+20	+20	+20	+7	+7	0	0	0	0	0	0
30	50	+180	+112	+41	+50	+64	+25	+34	+11	+16	+25	+39	+62	+100
		+80	+50	+25	+25	+25	+9	+9	0	0	0	0	0	0
50	80	+220	+134	+49	+60	+76	+29	+40	+13	+19	+30	+46	+74	+120
		+100	+60	+30	+30	+30	+10	+10	0	0	0	0	0	0
80	120	+260	+159	+58	+71	+90	+34	+47	+15	+22	+35	+54	+87	+140
		+120	+72	+36	+36	+36	+12	+12	0	0	0	0	0	0
120	180	+305	+185	+68	+83	+106	+39	+54	+18	+25	+40	+63	+100	+160
		+145	+85	+43	+43	+43	+14	+14	0	0	0	0	0	0
180	250	+335	+215	+79	+96	+122	+44	+61	+20	+29	+46	+72	+115	+185
		+170	+110	+50	+50	+50	+15	+15	0	0	0	0	0	0
250	315	+400	+240	+88	+108	+137	+49	+69	+23	+32	+52	+81	+130	+210
		+190	+110	+56	+56	+56	+17	+17	0	0	0	0	0	0
315	400	+440	+265	+98	+119	+151	+54	+75	+25	+36	+57	+89	+140	+230
		+210	+125	+62	+62	+62	+18	+18	0	0	0	0	0	0

	h11	js5	js6	j5	j6	k5	k6	m5	m6	n5	n6	p6	p5	over	up to
	0	+2	+3	+2	+4	+4	+6	+6	+8	+8	+10	+12	+10	-	3
	-60	-2	-3	-2	-2	0	0	+2	+2	+4	+4	+6	+6		
	0	+2.5	+4	+3	+6	+6	+9	+9	+12	+13	+16	+20	+17	3	6
	-75	-2.5	-4	-2	-2	+1	+1	+4	+4	+8	+8	+12	+12		
	0	+3	+4.5	+4	+7	+7	+10	+12	+15	+16	+19	+24	+21	6	10
	-90	-3	-4.5	-2	-2	+1	+1	+6	+6	+10	+10	+15	+15		
	0	+4	+5.5	+5	+8	+9	+12	+15	+18	+20	+23	+29	+26	10	18
	-110	-4	-5.5	-3	-3	+1	+1	+7	+7	+12	+12	+18	+18		
	0	+4.5	+6.5	+5	+9	+11	+15	+17	+21	+24	+28	+35	+31	18	30
	-130	-4.5	-6.5	-4	-4	+2	+2	+8	+8	+15	+15	+22	+22		
	0	+5.5	+8	+6	+11	+13	+18	+20	+25	+28	+33	+42	+37	30	50
	-160	-5.5	-8	-5	-5	+2	+2	+9	+9	+17	+17	+26	+26		
	0	+6.5	+9.5	+6	+12	+15	+21	+24	+30	+33	+39	+51	+45	50	80
	-190	-6.5	-9.5	-7	-7	+2	+2	+11	+11	+20	+20	+32	+32		
	0	+7.5	+11	+6	+13	+18	+25	+28	+35	+38	+45	+59	+52	80	120
	-220	-7.5	-11	-9	-9	+3	+3	+13	+13	+23	+23	+37	+37		
	0	+9	+12.5	+7	+14	+21	+28	+33	+40	+45	+52	+68	+61	120	180
	-250	-9	-12.5	-11	-11	+3	+3	+15	+15	+27	+27	+43	+43		
	0	+10	+14.5	+7	+16	+24	+33	+37	+46	+51	+60	+79	+70	180	250
	-290	-10	-14.5	-13	-13	+4	+4	+17	+17	+31	+31	+50	+50		
	0	+11.5	+16	+7	+16	+27	+36	+43	+52	+57	+66	+88	+79	250	315
	-320	-11.5	-16	-16	-16	+4	+4	+20	+20	+34	+34	+56	+56		
	0	+12.5	+18	+7	+18	+29	+40	+46	+57	+62	+73	+98	+87	315	400
	-360	-12.5	-18	-18	-18	+4	+4	+21	+21	+37	+37	+62	+62		

	JS7	JS6	J7	J6	K6	K7	M6	M7	N6	N7	N9	P7	P9	over	up to
	+5	+3	+4	+2	0	0	-2	-2	-4	-4	-4	-6	-6	-	3
	-5	-3	-6	-4	-6	-10	-8	-12	-10	-14	-29	-16	-31		
	+6	+4	+6	+5	+2	+3	-1	0	-5	-4	0	-8	-12	3	6
	-6	-4	-6	-3	-6	-9	-9	-12	-13	-16	-30	-20	-42		
	+7.5	+4.5	+8	+5	+2	+5	-3	0	-7	-4	0	-9	-15	6	10
	-7.5	-4.5	-7	-4	-7	-10	-12	-15	-16	-19	-36	-24	-51		
	+9	+5.5	+10	+6	+2	+6	-4	0	-9	-5	0	-11	-18	10	18
	-9	-5.5	-8	-5	-9	-12	-15	-18	-20	-23	-43	-29	-61		
	+10.5	+6.5	+12	+8	+2	+6	-4	0	-11	-7	0	-14	-22	18	30
	-10.5	-6.5	-9	-5	-11	-15	-17	-21	-24	-28	-52	-35	-74		
	+12.5	+8	+14	+10	+3	+7	-4	0	-12	-8	0	-17	-26	30	50
	-12.5	-8	-11	-6	-13	-18	-20	-25	-28	-33	-62	-42	-88		
	+15	+9.5	+18	+13	+4	+9	-5	0	-14	-9	0	-21	-32	50	80
	-15	-9.5	-12	-6	-15	-21	-24	-30	-33	-39	-74	-51	-106		
	+17.5	+11	+22	+16	+4	+10	-6	0	-16	-10	0	-24	-37	80	120
	-17.5	-11	-13	-6	-18	-25	-28	-35	-38	-45	-87	-59	-124		
	+20	+12.5	+26	+18	+4	+12	-8	0	-20	-12	0	-28	-43	120	180
	-20	-12.5	-14	-7	-21	-28	-33	-40	-45	-52	-100	-68	-143		
	+23	+14.5	+30	+22	+5	+13	-8	0	-22	-14	0	-33	-50	180	250
	-23	-14.5	-16	-7	-24	-33	-37	-46	-51	-60	-115	-79	-165		
	+26	+16	+36	+25	+5	+16	-9	0	-25	-14	0	-36	-56	250	315
	-26	-16	-16	-7	-27	-36	-41	-52	-57	-66	-130	-88	-186		
	+28.5	+18	+39	+29	+7	+17	-10	0	-26	-16	0	-41	-62	315	400
	-28.5	-18	-18	-7	-29	-40	-46	-57	-62	-73	-140	-98	-202		

11. Guide to queries

Company _____ Date _____
 Contact person _____ Offer valid until _____
 Position/department _____
 Address _____
 Phone _____ Fax _____
 E-mail _____
 Project description _____
 Unique needs _____ Number of item _____
 Series product _____ Items per yea _____
 Requested delivery date for: _____ Items _____ calender week
 New design _____ yea / no
 Cost reduction _____ Budget _____ Euro
 Alternative to competition _____ Competition product _____
 Technical upgrade _____ Previous solution _____

Application parameters

Mounting position: horizontal 0° vertical 90° Mounting angle: °
 Slider mass: kg Additional load (load stroke): kg
 Counter weight for lifting axis: kg
 Additional axial force (load stroke): kN Additional axial force (back stroke): kN
 Friction coefficient guiding system: Sealing resistance guiding system: kN
 Stroke: mm Safety overrun (floating bearing side): mm
 Number of steps load stroke:
 Velocity (load stroke): m/s Velocity (back stroke): m/s
 Acceleration (load stroke): m/s² Acceleration (back stroke): m/s²
 Alternative - travel time: s
 Cycle time: s
 Required service life time: cycles or h or km
 Operating conditions:

Dimensions / versions (if available)

Flange type nut cylindrical nut Threaded nut
 Nominal diameter: mm Pitch: mm
 Maximum nut diameter: mm Maximum nut length: mm
 Repeatability: mm
 Axial clearance: standard axial clearance Z0 without clearance Z1
 Preload: light preload Z2 medium preload Z3 high preload Z4
 Precision class ISO: T10 T7 T5 T3 T2 T1 T0
 P5 P3 P2 P1 P0
 Precision class JIS: C10 C7 C5 C3 C2 C1 C0

Mounting method

Position fixed bearing:

Mounting method:

above

below

fixed-fixed

fixed-supported

supported-supported

fixed-free

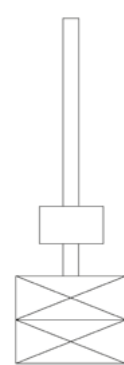
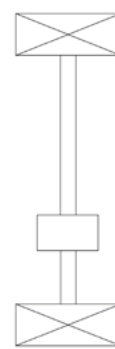
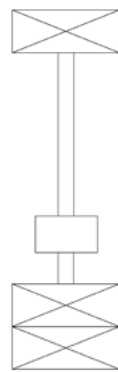
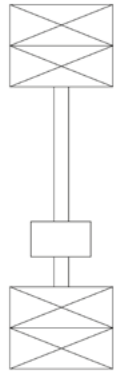

End machining

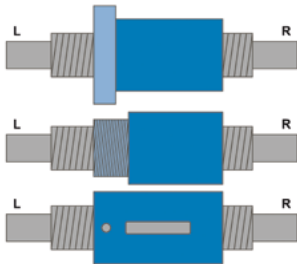

Left shaft end

Right shaft end

Standard end machining fixed bearing (Chapter 6.2).....

Standard end machining fixed bearing (Chapter 6.2).....

Standard end machining floating bearing (Chapter 6.2).....

Standard end machining floating bearing (Chapter 6.2).....

End machining according drawing no.

End machining according drawing no.

without end machining

without end machining

Additional information

12. Index

A		E	
Axial clearance	38, 42, 64	Efficiency	10
Axial load	31, 33, 37, 75, 77, 79, 81, 83, 84, 89, 91	External deflection	13
Maximum axial load	33, 77, 84	F	
Mean axial load	34	Factor according the bearing arrangement	36, 37
Axial rigidity	31, 32, 38	Flange design	11
B		G	
Backlash	38	Gothic arc groove geometry	7
Ball center to center diameter	8, 36, 39, 62, 63	Grinding	9
Ball deflection types	12, 13	Guide to queries	110, 111
External deflection	13	H	
Internal deflection	12	Hardness factor	33, 34
Ball diameter	8, 15	I	
Bearing arrangement	32, 35 - 38	Idling torque	10, 28, 29, 39
Bearing arrangement of Ball Screws	32, 35 - 38	Influence factors	10, 33, 34, 36, 37, 39, 47
Bearing units	75 - 93	Hardness factor	33, 34
Bearing units for Ball Screws for high loads	75 - 85	Load factor	34
Bearing units for Ball Screws for low and medium loads	86 - 93	Temperature factor	33, 34
Fixed bearings for Ball Screws	75 - 85, 88 - 91	Intended use	15
Fixed bearings for Ball Screws, block design	79 - 81, 88, 89	Internal deflection	12
Fixed bearings for Ball Screws, flange design	90, 91	L	
Fixed bearings for Ball Screws		Load factor	34
with mounting holes in the outer ring	82 - 85	Load rating	15, 31, 33, 34, 61
Floating bearings for Ball Screws, block design	85, 92	Dynamic load rating	15, 31, 34, 61
Floating bearings for Ball Screws, flange design	93	Static load rating	15, 33, 61
Self-locking precision nut	86, 87, 94	Lubrication	47
Buckling load	35, 37	Amounts of lubricant	53 - 56
C		Lubricants	86, 87, 94
Coatings	105	Lubrication interval	57, 58
Corrosion protection / Coatings	105	Lubrication methods	51, 52
Coupling cone	102	Lubrication points	52
Critical speed	35, 36	Lubrication connection	104
D		M	
Deflection belt drive	103, 104	Maintenance and lubrication	47 - 58
Design measures of Ball Screws	8	Amounts of lubricant	53 - 56
Ball center to center diameter	8, 36, 39, 62, 63	Lubricants	86, 87, 94
Ball diameter	8, 15	Lubrication interval	57, 58
Nominal diameter	8, 15, 21 - 26, 29, 41, 57, 62, 63, 66	Lubrication methods	51, 52
Outer diameter	42, 62, 63	Lubrication points	52
Pitch	8, 15, 21 - 26, 29, 41, 57, 62, 63, 66		
Pitch angle	8, 10, 39		
Root diameter	8, 32, 36, 37, 42, 62, 63		
Design principles	7		
Design types of nuts	59, 60		
DN value	36, 66		
Permissible DN values	36, 66		
Drive power	39		
Dynamic load rating	15, 31, 34, 61		

Manufacturing processes _____	8, 9
Grinding _____	9
Rolling _____	8
Whirling _____	9
Mounting _____	40 - 46
Design of the mounting surfaces _____	40, 41
Mounting instruction _____	42 - 46
Mounting of Ball Screws in machines _____	46
Mounting of Ball Screw nuts _____	42
Mounting of fixed bearings and fixed bearing units _____	43, 44
Mounting of floating bearings and floating bearing units _____	45
Mounting tolerances _____	40, 4

N

Nominal diameter _____	8, 15, 21 - 26, 29, 41, 57, 62, 63, 66
Nominal service life time _____	15, 16, 34
Nut series _____	59, 60

O

Operating temperature _____	15
Outer diameter _____	42, 62, 63

P

Pitch _____	8, 9, 17, 28, 30, 34, 38, 39, 57, 61, 64
Pitch angle _____	8, 10, 39
Position accuracy _____	31, 38
Axial rigidity _____	31, 32
Axial clearance _____	38, 42, 64
Surrounding structure _____	38
Thermal expansion _____	38
Preload _____	61, 64, 65
Preload classes _____	10, 28, 30, 31, 37, 39, 41, 42, 64, 75
Permissible DN values _____	36, 66

S

Safety instructions _____	16
Sealing options _____	66
Selection criteria _____	14
Selection of Ball Screws _____	16
Self-locking precision nut _____	86, 87, 94
Service life time _____	15, 16, 34, 40, 47
Nominal service life time _____	15, 16, 34
Shape and position tolerance _____	21 - 27
Standard end machining _____	95 - 101
Standards _____	15
Starting torque _____	28, 78
Starting torque of axial angular contact ball bearings _____	78
Starting torque of Ball Screws _____	28
Starting torque of bearing units _____	81, 89, 91
Static load rating _____	15, 33, 61
Static safety factor _____	15, 33, 61

R

Rigidity _____	6, 30, 31, 32, 38
Axial rigidity _____	31, 32, 38
Rolled shafts _____	62
Rolling _____	8
Root diameter _____	8, 32, 36, 37, 42, 62, 63

T

Temperature factor _____	33, 34
Tension - compression load _____	37
Test criteria _____	17 - 29
Thermal expansion _____	38
Tolerance classes _____	17 - 29
Transportation _____	40
Transportation and storage of Ball Screws _____	40
Type code _____	76, 80, 82, 106, 107
Type code Ball Screw _____	106, 107
Type code Ball Screw nut _____	106, 107
Type code Ball Screw shaft _____	106, 107
Type code fixed bearing type BST _____	76
Type code fixed bearing unit type BSTK _____	80
Type code fixed bearing with mounting holes in the outer ring type BSTU _____	82

W

Whirled shafts _____	63
Whirling _____	9

More information concerning our NTN-SNR products for Linear Motion is provided in our catalogues.



NTN-SNR Linear Motion
Linear Axis (AX)



NTN-SNR Linear Motion
Operating manual Linear Axis



NTN-SNR Linear Motion
Linear Guides (LG)



NTN-SNR Linear Motion
Ball Bushings (LBB)



NTN-SNR Linear Motion
Linear Axis AXE (AXE)



NTN-SNR Linear Motion
Operating manual Linear
Axis AXE

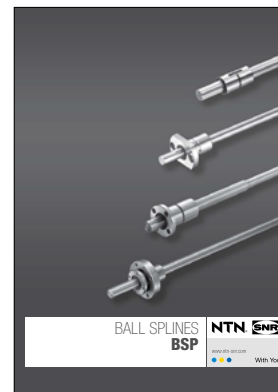

NTN-SNR Linear Motion
Ball Splines (BSP)



www.ntn-snr.com/documents/linear



NTN-SNR LINEAR MOTION BALL SCREWS

SNR WÄLZLAGER GMBH
Friedrich-Hagemann-Straße 66
D-33719 Bielefeld
Telefon: +49 (0) 5 21/9 24 00 -112
Telefax: +49 (0) 5 21/9 24 00 -97
email: linear@ntn-snr.de



www.ntn-snr.com/ball-screws

This document is the exclusive property of NTN-SNR ROULEMENTS. Any total or partial reproduction hereof without the prior consent of NTN-SNR ROULEMENTS is strictly prohibited. Legal action may be brought against anyone breaching the terms of this paragraph. NTN-SNR ROULEMENTS shall not be held liable for any errors or omissions that may have crept into this document despite the care taken in drafting it. Due to our policy of continuous research and development, we reserve the right to make changes without notice to all or part of the products and specifications mentioned in this document.

© NTN-SNR ROULEMENTS, international copyright 2021.

NTN-SNR ROULEMENTS - 1 rue des Usines - 74000 Annecy
RCS ANNECY B 325 821 072 - Code APE 2815Z - Code NACE 28.15
www.ntn-snr.com

NTN 



With You

